

Safety and Copyright

Federal Communication Commission (FCC) Statement

This device complies with Part 15 of the FCC rules. Operation is subject to the following two conditions:

1. This device may not cause harmful interference, and
2. This device must accept any interference received, including interference that may cause undesired operation.

Copyright

TORX® is a trademark of Textron Inc.



Industry Canada (IC) Statement

This device complies with Industry Canada License-exempt RSS standard(s). Operation is subject to the following two conditions:

1. This device may not cause interference, and
2. This device must accept any interference, including interference that may cause undesired operation of the device.

Le présent appareil est conforme aux CNR d'Industrie Canada applicables aux appareils radio-exempt de licence. L'exploitation est autorisée aux deux conditions suivantes:

1. l'appareil ne doit pas produire de brouillage, et
2. l'utilisateur de l'appareil doit accepter tout brouillage radioélectrique subi, même si le brouillage est susceptible d'en compromettre le fonctionnement.

Short information

The SE88 is an asset transmitter designed to work with the Security Escort system. When initiated, a signal identifying the asset and location is sent to the security office at regular intervals. SE88 can be tested within sight of a receiver or siren/strobe.

Notice!

The Security Escort system is not a substitute for safe behavior. System users should not take personal risks under the misconception the system provides protection that compensates for taking such risks.



Overview

The overview specifications of the transmitter are as follows:

SE88A-90S	Provides a supervisory transmission to the Security Escort System every 90 seconds
Battery	Lithium coin cell battery. Duracell DL2032, Eveready CR2032, Panasonic CR2032
Operating Temperature	0° C to +60° C (-32° F to +140° F)
Enclosure Dimension (W x H x D)	31 mm x 54 mm x 7.5mm (1.22 in x 2.12 in x 0.3 in)

Tab. 1: Specifications

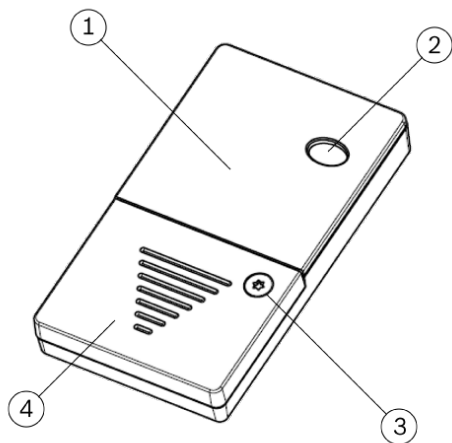

Fig. 1: SE88 Asset Transmitter Parts

1	Enclosure	2	Test Button
3	Screw	4	Slide Cover

Testing the Transmitter

Test the transmitter weekly. To verify transmitter operation:

1. You must be in sight of a Security Escort Siren/Strobe or a Security Escort Receiver. Receivers are located inside buildings usually within sight of an exit door. They are mounted on walls in light beige, rectangular enclosures. Siren/strobe is typically mounted on outside building walls and on light poles.
2. Press the Test button on your transmitter for about 1 second and release it.
3. Look for a flashing strobe on a siren/strobe, or a flashing green light on a receiver. These indicators confirm that the entire system is working. If you do not see the flashing light or flashing strobe, the test was not successful.

Notice!



Before the flashing light appears, there might be a brief delay of 2 or 3 seconds.

Notice!



For testing of the transmitter using siren, the siren needs to be connected to the strobe output (ST-) and not the siren output (SI-) of the Alert Unit. Please refer to the wiring in the *EA120B Alert Unit Installation Instructions*.

If there is no response, try the test again. If there is no response the second time, your transmitter may not be working. Take the transmitter to the security office.

Installing/Changing Batteries

Assuming normal usage (such as weekly testing), the battery life of SE88A-90S should be approximately 1 year.

If the battery is weak, a special signal is sent to the security office during any test, alarm, or supervisory transmission. Tests do not produce a flashing light on a receiver or siren/strobe when your transmitter has a weak battery.

Notice!



This equipment can be damaged by static electricity. Use a ground strap or grounded workstation when changing batteries.

You need a TORX® T5 wrench to replace the batteries.

1. Remove the screw from the slide cover.
2. Remove the slide cover from the enclosure.
3. Insert the battery, placing the + (positive) side of the battery away from the enclosure.

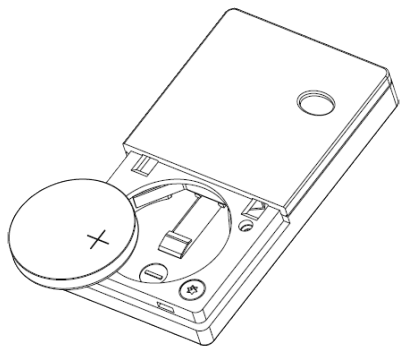

4. Ease the slide cover into position and press to snap it in place.
5. Insert the screw on the slide cover and tighten.

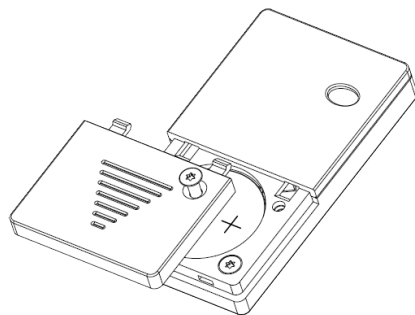

6. Test the transmitter for proper operation.

Tips for Better Transmission

As with all radio equipment, the signal strength from the transmitter is reduced by metal and wet surfaces and to some extent by the human body.

Battery Life

Assuming normal usage (such as weekly testing), the battery lasts approximately one year. If the battery is weak, a special signal is sent to the security office during a test. This test will not produce a flashing light on the receiver or siren/strobe.

Exposure to Moisture

Test the transmitter a few times (several hours apart) once exposed to moisture to verify it is working properly.

Important Information for Users of Security Escort System

Protected Areas

Check with the security department to verify the exact areas of the facility that are protected by the system and those that are not.

Lost or Stolen Transmitters

If your transmitter is lost or stolen, report the incident immediately to the security office so a replacement can be issued and the original transmitter can be deleted from the system.

SE88A Series Asset Transmitters

SE88A-90S-304



en User Manual

Robert Bosch (SEA) Pte Ltd

11 Bishan Street 21
573943 Singapore
Singapore

www.boschsecurity.com

© Robert Bosch (SEA) Pte Ltd, 2016

Bosch Sicherheitssysteme GmbH

Robert-Bosch-Ring 5
85630 Grasbrunn
Germany

© Bosch Sicherheitssysteme GmbH, 2016