

PRA-CSEK Call station extension kit

PRAESENSA

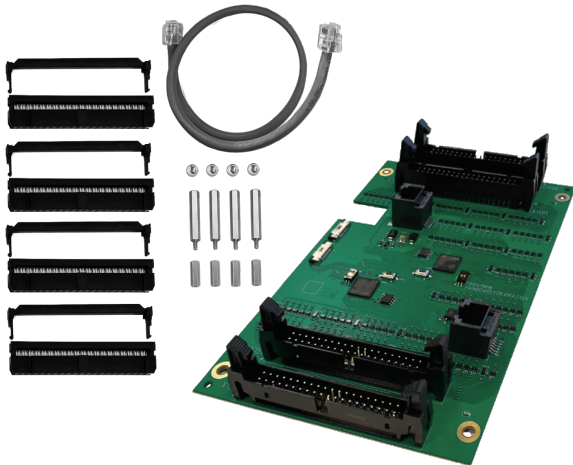

The call station extension kit is an open frame call station extension to create dedicated full custom operator panels for PRAESENSA public address systems. The extension kit connects to the basic call station kit PRA-CSBK, offering the same functionalities as two PRA-CSE devices without the integrated switches and indicators.

The extension kit has a CAN-bus interface on RJ12 to the PRA-CSBK, which is also used for power. A second RJ12-connection allows for loop-through to another PRA-CSEK. Each PRA-CSEK accepts up to 24 external selection switches and the associated status LEDs. Up to five status LEDs can be connected for each switch. These LEDs are similar to what the PRA-CSE provides for each key.

The PRA-CSEK is considered a component that must be installed in a final product. The final product must be reconfirmed to meet the applicable EMC directives.

Functions

Business operation

- One or two PRA-CSEK extension kits can be connected to a PRA-CSBK, each with connections for up to 24 switches that can be configured for various functions. The switches are especially useful for zone selection on a synoptic panel, giving a clear overview of the accessible zones and their location. The LED indicators for each switch show the status of the respective zone, such as selected, occupied or at fault.

- ▶ Open frame extension keypad for PRA-CSBK
- ▶ Enables compact, full custom call stations or call panels
- ▶ Connects to a maximum of 24 external selection switches with associated status indicators
- ▶ RJ12-connection to PRA-CSBK for power and CAN-bus data and loop-through connection to a second PRA-CSEK
- ▶ For stacked or side-by-side mounting with PRA-CSBK

- The PRA-CSEK is intended for the PRA-CSBK, but it can also be used with a PRA-CSLD, a PRA-CSLW, as well as one or two PRA-CSE.
- Each PRA-CSEK is configured as two PRA-CSE extensions, the first one for switches 1-12 and 13-24 and a second one for switches 25-36 and 37-48.
- The call station extension kit can also be used to create full custom emergency panels with all required functionalities. However, the PRA-CSBK and PRA-CSEK are components of a final product and, as such, cannot be certified for voice alarm purposes. The final product must be reconfirmed to meet the applicable voice alarm standards, or must be certified on a project basis by the Authorities Having Jurisdiction.
- All the indicators connected to the extension kit are part of the indicator test function of the connected call station kit.

Connection

- External switches and associated indicators can be connected to the PRA-CSEK in sets of six through a 40-way ribbon cable with lockable IDC-connector (Insulation Displacement Connector). The connector uses a two-row pin spacing of 2.54 mm (0.1 in). The ribbon cable uses a wire spacing of 1.27 mm (0.05 in).
- The PRA-CSEK is powered from the PRA-CSBK through a 6-pin RJ12-interconnection cable that also serves for CAN-bus data transfer. A second RJ12 connector loops-through to a subsequent PRA-CSEK.

- The extension kits are automatically addressed. The first one is connected to the PRA-CSBK for switches 1-24. The second one is connected to the first extension kit for switches 25-48.

Mounting

- The first PRA-CSEK can be mounted on top of the PRA-CSBK, with the second PRA-CSEK mounted on top of the first. Mounting accessories for stack-mounting are included. The kits can also be mounted side-by-side with the same included RJ12-cable.
- Due to the high number of interconnections, it is strongly advised to mount the switches and the LED indicators on a PCB of the required size with shrouded pin headers (2 x 20), like the ones used on the PRA-CSEK. A standard 40-way ribbon cable can be used for the interconnection.

Connection and functional diagram

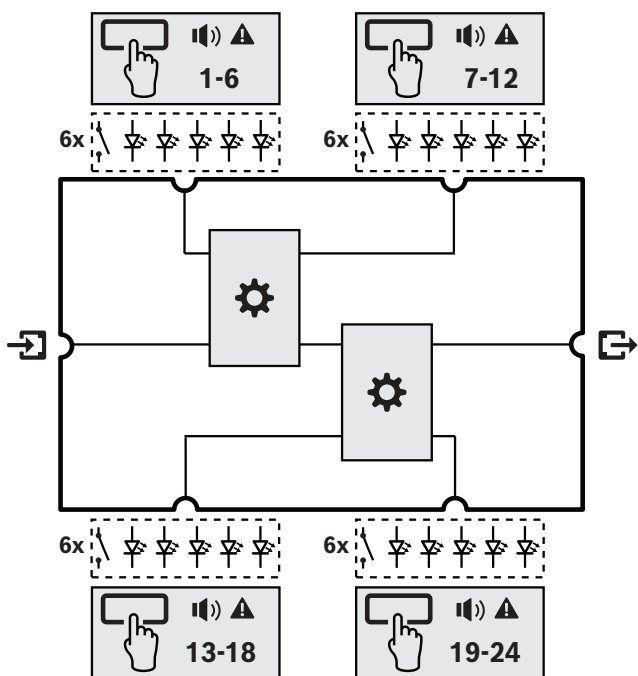

	Controller
--	------------

Top side interconnections

	Input connection (RJ12) from PRA-CSBK or previous PRA-CSEK	
	Output connection (RJ12) to subsequent PRA-CSEK	

	Connection to switches and indicators for zone/function 1-6 / 7-12 / 13-18 / 19-24:	
	- White: Selection	
	- Red: Evacuation call	
	- Blue: Business call	
	- Green: Music	
	- Yellow: Zone fault	

Architects' and engineers' specifications

The call station extension kit shall be designed exclusively for use with Bosch PRAESENSA systems. In cooperation with the basic call station kit, the call station extension kit shall offer connection facilities for up to 24 configurable switches with associated selection and status indicators for zone selection and other purposes. The call station extension kit shall have a CAN-bus interface for communication with the basic call station kit, with a loop-through connection to facilitate a subsequent call station kit. The call station extension kit shall be marked for CE and be compliant with the RoHS directive. Warranty shall be three years minimum. The call station extension shall be a Bosch PRA-CSEK.

Regulatory information

Regulatory areas	
Environment	EN/IEC 63000

Parts included

Quantity	Component
1	Call station extension kit
4	2 x 20-pin IDC connectors for ribbon cable
1	RJ12 interconnection cable
4	Mounting studs, M3 x 35 mm
4	Mounting inserts, M3 x 14 mm
4	Screws M3 x 8 mm, Tx10
1	Quick installation guide
1	Safety and security information

Technical specifications

Electrical

Power transfer

Input voltage (VDC)	5 VDC
Input voltage (VDC) (tolerance)	4.5 VDC – 5.5 VDC
Power consumption (W) (indicators on / off)	2 W / 0.2 W

Supervision

Interconnection	Link presence
Protection (processor)	Watchdog

Environmental

Operating temperature (°C)	-5 °C – 50 °C
Operating temperature (°F)	23 °F – 122 °F
Storage temperature (°C)	-30 °C – 70 °C
Storage temperature (°F)	-22 °F – 158 °F
Operating relative humidity, non-condensing (%)	5% – 95%
Installation altitude (m)	-500 m – 5,000 m
Installation altitude (ft)	-1,640 ft – 16,404 ft
Operating vibration	
Amplitude (mm)	< 0.35 mm
Acceleration (G)	< 5 G
Bump (transport) (G)	< 10 G (IEC 60068-2-27)

Mechanical

Dimensions (H x W x D) (mm)	158 mm x 105 mm x 32 mm
Dimensions (H x W x D) (in)	6.22 in x 4.13 in x 1.26 in
Weight (g)	105 g
Weight (lb)	0.23 lb

Ordering information

PRA-CSEK Call station extension kit

Extension to PRA-CSBK to connect up to 24 configurable switches and associated status indicators.
Order number **PRA-CSEK | F.01U.420.426**

Represented by:

Europe, Middle East, Africa:
Bosch Security Systems B.V.
P.O. Box 80002
5600 JB Eindhoven, The Netherlands
Phone: + 31 40 2577 284
www.boschsecurity.com/xc/en/contact/
www.boschsecurity.com

Germany:
Bosch Sicherheitssysteme GmbH
Robert-Bosch-Ring 5
85630 Grasbrunn
Tel.: +49 (0)89 6290 0
Fax: +49 (0)89 6290 1020
de.securitysystems@bosch.com
www.boschsecurity.com

North America:
Bosch Security Systems, LLC
130 Perinton Parkway
Fairport, New York, 14450, USA
Phone: +1 800 289 0096
Fax: +1 585 223 9180
onlinehelp@us.bosch.com
www.boschsecurity.com

Asia-Pacific:
Robert Bosch (SEA) Pte Ltd, Security Systems
11 Bishan Street 21
Singapore 573943
Phone: +65 6571 2808
Fax: +65 6571 2699
www.boschsecurity.com/xc/en/contact/
www.boschsecurity.com