

# **PRAESENSA**

Public Address and Voice Alarm System



# Table of contents

<b>1</b>	<b>Important product information</b>	<b>11</b>
1.1	Safety information	11
1.2	Disposal instructions	12
1.3	FCC and ICES 003	12
1.3.1	Class A notice	12
1.3.2	Suppliers Declaration of Conformity	12
<b>2</b>	<b>About this manual</b>	<b>15</b>
2.1	Intended audience	16
2.2	Training	16
2.3	Related documentation	16
2.3.1	Other related documentation	16
2.4	Listing of open source components	16
2.5	Copyright notice	17
2.6	Trademarks	17
2.7	Notice of liability	17
2.8	Document history	18
<b>3</b>	<b>System introduction</b>	<b>19</b>
3.1	Product overview	19
3.2	High level system characteristics	22
<b>4</b>	<b>General installation procedures and instructions</b>	<b>25</b>
4.1	Location of racks and enclosures	25
4.2	Unpacking products	27
4.3	Equipment racks and cabinets	27
4.4	Mounting the 19"-rack devices	27
4.5	Cable requirements	29
4.5.1	Precautions	29
4.5.2	Cable type recommendations	30
4.6	Network requirements and considerations	34
4.6.1	Network topology	34
4.6.2	Network connector ports	34
4.6.3	Audio content and device control	35
4.6.4	Network security	35
4.6.5	Network speed and bandwidth usage	36
4.6.6	System size limits	36
4.6.7	Network switches	37
4.6.8	Setting up connections	39
4.6.9	Network redundancy	39
4.6.10	IP-addressing	39
4.6.11	Transmission methods	41
4.7	Security precautions	42
4.8	System topologies	45
4.8.1	System in a single subnet	45
4.8.2	System with multiple subsystems in a single subnet	45
4.8.3	System with devices in different subnets	46
4.8.4	System with multiple subsystems in different subnets	47
4.9	Port numbers	47
<b>5</b>	<b>System composition</b>	<b>51</b>
5.1	Constant voltage systems	51

5.2	Amplifier selection	52
5.3	Amplifier power and crest factor	54
5.4	Battery calculation	55
5.4.1	Topology	55
5.4.2	Operating conditions	56
5.4.3	Power consumption	59
5.4.4	Accurate battery size calculation	61
5.4.5	Quick battery size calculation	62
5.4.6	Uninterruptable power supply size calculation	63
5.5	Heat loss calculation	65
6	<b>From installation to configuration</b>	67
6.1	MAC-addresses and hostname	67
6.2	Connecting the system controller	68
6.3	Network connections to devices	69
6.3.1	Star topology	69
6.3.2	Tree topology	69
6.3.3	Ring topology	69
6.3.4	Hop count	70
6.4	Device status and reset	71
6.5	Compatibility and certification overview	74
7	<b>System controller (SCL, SCS)</b>	75
7.1	Introduction	75
7.2	Functions	75
7.3	Functional diagram	76
7.4	System controller variants	76
7.5	Indicators and connections	78
7.6	Installation	78
7.6.1	Parts included	78
7.6.2	Memory card	79
7.6.3	Power supply	80
7.6.4	Ethernet network	81
7.6.5	Internal battery	82
7.6.6	Reset to factory default	82
7.7	Approvals	83
7.8	Technical data	83
8	<b>Amplifier, 600W 4-channel (AD604)</b>	86
8.1	Introduction	86
8.2	Functions	86
8.3	Functional diagram	88
8.4	Indicators and connections	89
8.5	Installation	90
8.5.1	Parts included	90
8.5.2	Safety ground	91
8.5.3	Power supply	92
8.5.4	Lifeline	92
8.5.5	Amplifier outputs	94
8.5.6	Ethernet network	100
8.5.7	Reset to factory default	100
8.6	Approvals	101

8.7	Technical data	101
9	<b>Amplifier, 600W 8-channel (AD608)</b>	<b>105</b>
9.1	Introduction	105
9.2	Functions	105
9.3	Functional diagram	106
9.4	Indicators and connections	107
9.5	Installation	108
9.5.1	Parts included	108
9.5.2	Safety ground	109
9.5.3	Power supply	109
9.5.4	Lifeline	110
9.5.5	Amplifier outputs	112
9.5.6	Ethernet network	118
9.5.7	Reset to factory default	119
9.6	Approvals	119
9.7	Technical data	119
10	<b>End-of-line device (EOL)</b>	<b>124</b>
10.1	Introduction	124
10.2	Product variant PRA-EOL-US	124
10.3	Functions	124
10.4	Functional diagram	125
10.5	Connections	125
10.6	Installation	125
10.6.1	Parts included	125
10.6.2	Wiring	127
10.6.3	Mounting	129
10.7	Approvals	130
10.8	Technical data	130
11	<b>Multifunction power supply, large (MPS3)</b>	<b>132</b>
11.1	Introduction	132
11.2	Functions	132
11.3	Functional diagram	134
11.4	Indicators and connections	135
11.5	Installation	136
11.5.1	Parts included	136
11.5.2	Battery and fuse	137
11.5.3	Mains power connection	145
11.5.4	Amplifier power supply	146
11.5.5	Lifeline	147
11.5.6	Power supply connection to system controller	149
11.5.7	Power over Ethernet	150
11.5.8	Ethernet network	150
11.5.9	Control inputs	152
11.5.10	Control outputs	154
11.5.11	Reset to factory default	154
11.6	Approvals	155
11.7	Technical data	156
12	<b>Ambient noise sensor (ANS)</b>	<b>160</b>
12.1	Introduction	160

12.2	Functions	160
12.3	Functional diagram	161
12.4	Indicators and connections	161
12.5	Installation	162
12.5.1	Parts included	162
12.5.2	Power over Ethernet	163
12.5.3	Ethernet network	163
12.5.4	Positioning of ambient noise sensors	163
12.5.5	Water resistance	164
12.5.6	Front cover and logo orientation	165
12.5.7	Flush mounting outdoors	165
12.5.8	Surface mounting outdoors	167
12.5.9	Mounting indoors	168
12.5.10	Reset to factory default	168
12.6	Approvals	169
12.7	Technical data	169
13	<b>Control interface module (IM16C8)</b>	171
13.1	Introduction	171
13.2	Functions	171
13.3	Functional diagram	172
13.4	Indicators and connections	173
13.5	Installation	174
13.5.1	Parts included	174
13.5.2	DIN rail installation	174
13.5.3	Safety ground	175
13.5.4	Power over Ethernet	177
13.5.5	Connection to the system controller	177
13.5.6	Control inputs 1-16	178
13.5.7	Control outputs 1-8	179
13.5.8	Trigger outputs A-B	180
13.5.9	Effects of the interconnection faults	181
13.5.10	Reset to factory default	181
13.5.11	Device recovery	181
13.6	Approvals	182
13.7	Technical data	182
14	<b>LCD call station (CSLD, CSLW)</b>	185
14.1	Introduction	185
14.2	Functions	185
14.3	Functional diagram	186
14.4	Indicators and connections	187
14.5	Installation	188
14.5.1	Parts included	188
14.5.2	Interconnection call station / extension	189
14.5.3	Power over Ethernet	189
14.5.4	Ethernet network	190
14.5.5	Line input	192
14.5.6	Call station microphone frequency response	193
14.5.7	Microphone connection diagram	194
14.5.8	Mounting	195

14.5.9	Reset to factory default	196
14.6	Approvals	196
14.7	Technical data	197
<b>15</b>	<b>Call station extension (CSE)</b>	<b>200</b>
15.1	Introduction	200
15.2	Functions	200
15.3	Functional diagram	201
15.4	Indicators and connections	201
15.5	Installation	202
15.5.1	Parts included	202
15.5.2	Extension connected to a call station	203
15.5.3	Labeling	204
15.5.4	Mounting a button cap	206
15.6	Approvals	208
15.7	Technical data	208
<b>16</b>	<b>Call station kit (CSBK)</b>	<b>210</b>
16.1	Introduction	210
16.2	Functions	210
16.3	Functional diagram	211
16.4	Indicators and connections	212
16.5	Installation	213
16.5.1	Parts included	214
16.5.2	Enclosure requirements	215
16.5.3	Mounting	215
16.5.4	Microphone connection	216
16.5.5	Loudspeaker connection	218
16.5.6	Status LEDs connections	219
16.5.7	Interconnection call station / extension	220
16.5.8	Power over Ethernet	222
16.5.9	Ethernet network	223
16.5.10	Line input	223
16.5.11	Reset to factory default	224
16.6	Approvals	225
16.7	Technical data	225
<b>17</b>	<b>Call station extension kit (CSEK)</b>	<b>228</b>
17.1	Introduction	228
17.2	Functions	228
17.3	Functional diagram	229
17.4	Indicators and connections	229
17.5	Installation	230
17.5.1	Parts included	230
17.5.2	Enclosure requirements	230
17.5.3	Mounting	231
17.5.4	Vertical mounting	231
17.5.5	Horizontal mounting	232
17.5.6	Crimp the ribbon cables into the IDC connector	233
17.5.7	Insert the IDC connectors	234
17.5.8	Pin assignment of the connectors	235
17.6	Approvals	238

17.7	Technical data	238
18	<b>Wall control panel (WCP-EU, WCP-US)</b>	240
18.1	Introduction	240
18.2	Functions	240
18.3	Functional diagram	241
18.4	Dimensions	242
18.5	Indicators and connections	244
18.6	Installation	244
18.6.1	Parts included	245
18.6.2	Power over Ethernet	245
18.6.3	Ethernet network	246
18.6.4	Change the front color of the device	246
18.6.5	Wall mounting	246
18.6.6	Operation	247
18.6.7	Reset to factory default	248
18.7	Approvals	248
18.8	Technical data	248
19	<b>Ethernet switch (ES8P2S)</b>	251
19.1	Introduction	251
19.2	Functions	251
19.3	Functional diagram	252
19.4	Indicators and connections	253
19.5	Installation	254
19.5.1	Parts included	255
19.5.2	Power supply connection	255
19.5.3	Fault relay connection	256
19.6	Approvals	256
19.7	Technical data	257
20	<b>Fiber transceiver (SFPLX, SFPSX)</b>	260
20.1	Introduction	260
20.2	Functions	260
20.3	Functional diagram	260
20.4	Installation	261
20.4.1	Parts included	261
20.4.2	Application	261
20.4.3	Transceiver	262
20.4.4	Fiber cable	262
20.5	Approvals	263
20.6	Technical data SFPSX	263
20.7	Technical data SFPLX	264
21	<b>Public Address server (APAS)</b>	266
21.1	Introduction	266
21.2	Functions	266
21.3	Functional diagram	267
21.4	Indicators and connections	268
21.5	Installation	269
21.5.1	Parts included	269
21.5.2	Power adapter	269
21.5.3	Mounting bracket	269



21.5.4	Network connections	270
21.5.5	Configuration	270
21.6	Approvals	270
21.7	Technical data	270
<b>22</b>	<b>Power supply module (PSM24, PSM48)</b>	<b>273</b>
22.1	Introduction	273
22.2	Functions	273
22.3	Functional diagram	274
22.4	Indicators and connections	274
22.5	Installation	275
22.5.1	Parts included	276
22.5.2	Mounting	276
22.5.3	Mains connection	277
22.5.4	Output connection	277
22.5.5	Thermal behavior	278
22.6	Approvals	278
22.7	Technical data	278
<b>23</b>	<b>Application notes</b>	<b>281</b>
23.1	Connecting 100 Mbps-devices	281
23.2	Long range interconnections	281
23.3	Compatibility with other network data	282
23.4	Static IP-binding	282
23.5	AVC and the positioning of Ambient noise sensors	285
23.6	Resilience of EOL-supervision for high frequency tones	289
23.7	Lightning protection for loudspeaker cables	290
<b>24</b>	<b>Troubleshooting</b>	<b>291</b>
<b>25</b>	<b>Maintenance and service</b>	<b>293</b>
25.1	Preventive maintenance	293
25.2	Corrective maintenance	294
25.3	Device replacement	294
25.3.1	System controller	294
25.3.2	Amplifier	295
25.3.3	Multifunction power supply	296
25.3.4	Call station	297
25.3.5	Ambient noise sensor	297
25.3.6	Control interface module	298
25.3.7	Wall control panel	299
<b>26</b>	<b>EN 54-16 / EN 54-4 compliance</b>	<b>300</b>
26.1	Introduction	300
26.2	Checklist	300
26.3	Rack label	305
<b>27</b>	<b>ISO 7240-16 / ISO 7240-4 compliance</b>	<b>306</b>
27.1	Introduction	306
27.2	Checklist	306
27.3	Rack label	310
<b>28</b>	<b>UL 2572 / UL 864 compliance</b>	<b>311</b>
28.1	Introduction	311
28.2	Checklist	311
<b>29</b>	<b>DNV-GL type approval</b>	<b>314</b>

---

29.1	Introduction	314
29.2	Checklist	314
30	<b>Architects' and engineers' specifications</b>	<b>318</b>
30.1	System	318
30.2	System controller (SCL, SCS)	319
30.3	Amplifier, 600W 4-channel (AD604)	319
30.4	Amplifier, 600W 8-channel (AD608)	320
30.5	End-of-line device (EOL)	320
30.6	Multifunction power supply, large (MPS3)	320
30.7	Ambient noise sensor (ANS)	321
30.8	Control interface module (IM16C8)	321
30.9	LCD call station (CSLD, CSLW)	321
30.10	Call station extension (CSE)	322
30.11	Call station kit (CSBK)	322
30.12	Call station extension kit (CSEK)	323
30.13	Wall control panel (WCP-EU, WCP-US)	323
30.14	Public address server (APAS)	323
30.15	Public address license (APAL)	323
30.16	Ethernet switch (ES8P2S)	324
30.17	Fiber transceiver (SFPLX, SFPSX)	324
30.18	Power supply module (PSM24, PSM48)	324
30.19	License for subsystem PRAESENSA (LSPRA)	325
31	<b>Tones</b>	<b>326</b>
31.1	Alarm tones	326
31.2	Attention tones	330
31.3	Silence tones	333
31.4	Test tones	333
32	<b>Support and academy</b>	<b>335</b>

---

# 1 Important product information

## 1.1 Safety information

1. Read and keep these safety instructions. Follow all instructions and heed all warnings.
2. Download the latest version of the applicable installation manual from [www.boschsecurity.com](http://www.boschsecurity.com) for installation instructions.



### Information

Refer to the Installation Manual for instructions.

3. Follow all installation instructions and observe the following alert signs:



**Notice!** Containing additional information. Usually, not observing a notice does not result in damage to the equipment or personal injuries.



**Caution!** The equipment or the property can be damaged, or persons can be injured if the alert is not observed.





**Warning!** Risk of electric shock.

4. System installation and servicing by qualified personnel only, in accordance with applicable local codes. No user-serviceable parts inside.
5. System installation for emergency sound (except for call stations and call station extensions) in a Restricted Access Area only. Children may not get access to the system.
6. For rack-mounting of system devices, make sure that the equipment rack is of suitable quality to support the weight of the devices. Use caution when moving a rack to avoid injury from tip over.
7. The apparatus shall not be exposed to dripping or splashing and no objects filled with liquids, such as vases, shall be placed on the apparatus.



**Warning!** To reduce the risk of fire and electric shock, do not expose this apparatus to rain or moisture.

8. Mains powered equipment shall be connected to a mains power outlet socket with a protective earthing connection. An external, readily operable, mains plug or all-pole mains switch shall be installed.
9. Only replace the mains fuse of an apparatus with a fuse of the same type.
10. The protective ground connection of an apparatus shall be connected to protective ground before the apparatus is connected to a power supply.
11. Amplifier outputs marked with  may carry audio output voltages up to 120 V<sub>RMS</sub>. Touching uninsulated terminals or wiring may result in an unpleasant sensation. Amplifier outputs marked with  or  may carry audio output voltages above 120 V<sub>RMS</sub>. It requires a skilled person to strip and connect the loudspeaker wires in such a way that the naked conductors are inaccessible.
12. The system may receive power from multiple mains power outlet sockets and backup batteries.



**Warning!** To prevent a shock hazard disconnect all power sources prior to system installation.

13. Only use recommended batteries and observe polarity. Risk of explosion if an incorrect type of battery is used.
14. Fiber optical converters use invisible laser radiation. To prevent injury, avoid eye exposure to the beam.
15. Devices for vertical (wall) mounting supporting a user interface for operation shall only be mounted below 2 m height.
16. Devices installed above 2 m height may cause injury when falling down. Preventive measures must be taken.
17. To prevent hearing damage do not listen at high volume levels for long periods.
18. An apparatus may use a lithium coin battery. Keep away from children. If ingested, high risk of chemical burn hazard. Seek medical attention immediately.

## 1.2 Disposal instructions



### Old electrical and electronic appliances.

Electrical or electronic devices that are no longer serviceable must be collected separately and sent for environmentally compatible recycling (in accordance with the European Waste Electrical and Electronic Equipment Directive).

To dispose of old electrical or electronic devices, you should use the return and collection systems put in place in the country concerned.

## 1.3 FCC and ICES 003

### 1.3.1 Class A notice

*applies to U.S.A. and Canadian models only*



### Business Equipment

#### For commercial or professional use

This equipment has been tested and found to comply with the limits for a Class A digital device, pursuant to Part 15 of the FCC and Canadian ICES-003 requirements. These limits are designed to provide reasonable protection against harmful interference when the equipment is operated in a commercial environment. This equipment generates, uses, and can radiate radio frequency energy and, if not installed and used in accordance with the instruction manual, may cause harmful interference to radio communications. Operation of this equipment in residential area is likely to cause harmful interference in which case the user will be required to correct the interference at their own expense. Intentional or unintentional changes or modifications not expressly approved by the party responsible for compliance shall not be made. Any such changes or modifications may void the user's authority to operate the equipment.

### 1.3.2 Suppliers Declaration of Conformity

Material	Commercial code	Material description
F.01U.325.042	PRA-SCL	System controller, large
F.01U.325.040	PRA-SCS	System controller, small
F.01U.325.043 / F.01U.399.142	PRA-AD604	Amplifier, 600W 4-channel
F.01U.325.044 / F.01U.399.143	PRA-AD608	Amplifier, 600W 8-channel

F.01U.378.928	PRA-ANS	Ambient noise sensor
F.01U.325.046 / F.01U.399.155	PRA-MPS3	Multifunction power supply, large
F.01U.378.929	PRA-IM16C8	Control interface module, 16x8
F.01U.325.048	PRA-CSLD	Desktop LCD call station
F.01U.325.358 / F.01U.415.307	PRA-CSLW	Wallmount LCD call station
F.01U.325.357	PRA-CSE	Call station extension
F.01U.394.535	PRA-WCP-EU	Wall control panel, EU-style
F.01U.394.536	PRA-WCP-US	Wall control panel, US-style
F.01U.394.306	PRA-FRP3-US	First responder panel USA, 3- extension
F.01U.396.446	PRA-FRP3-USNY	First responder panel NY US, 3-extension
F.01U.360.285	OMN-DANTEGTW	Dante gateway

#### Compliance statement

This device complies with part 15 of the FCC Rules. Operation is subject to the following two conditions: (1) This device may not cause harmful interference, and (2) this device must accept any interference received, including interference that may cause undesired operation.

#### Responsible party

Bosch Security Systems, LLC  
130 Perinton Parkway  
14450 Fairport, NY, USA  
[www.boschsecurity.us](http://www.boschsecurity.us)

For the following products, the original manufacturer is the responsible party for the FCC Suppliers Declaration of Conformity.

Material	Commercial code	Original manufacturer	Bosch order code
F.01U.352.102	EKI-7710G-2CP- A1801-T	Advantech	PRA-ES8P2S
F.01U.352.103	SFP-GLX/LCI-10	Advantech	PRA-SFPLX
F.01U.352.104	SFP-GSX/LCI	Advantech	PRA-SFPSX
F.01U.354.303	ARK-1124H-S6A3	Advantech	PRA-APAS
F.01U.404.039	ARK-1124H-S6A3	Advantech	PRA-APAS-US
F.01U.358.130 / F.01U.410.357	DRP048V240W1BK	Delta	PRA-PSM48

F.01U.358.131 / F.01U.410.358	DRP024V240W1BK	Delta	PRA-PSM24
----------------------------------	----------------	-------	-----------

## 2 About this manual

The purpose of this installation manual is to provide all required information needed for the installation and interconnection of the Bosch PRAESENSA products. It will guide new installers step-by-step and serves as a reference for experienced installers.

- Unless required for the installation of the products, this manual does not describe software installation, configuration and operating/user instructions. Refer to *Related documentation, page 16*.
- This manual, or an update, in pdf format is available as download from [www.boschsecurity.com](http://www.boschsecurity.com) > PRAESENSA product section > System overview > Documents tab.

Refer to the following sections before and during installation and maintenance of your system:

- **Chapter 1: Important product information, page 11.** Contains important instructions and safeguards, which you should read before installing or using your system.
- **Chapter 2: About this manual, page 15.** Gives information on the intended audience, training, available documentation and explains how to use this manual.
- **Chapter 3: System introduction, page 19.** Provides a high-level introduction description of the PRAESENSA Public Address and Voice Alarm System. Includes a brief product description and overview.
- **Chapter 4: General installation procedures and instructions, page 25.** Describes considerations for rack building, cable selection and network design.
- **Chapter 5: System composition, page 51.** Describes considerations and methods for system composition, battery calculation and heat loss.
- **Chapter 6: From installation to configuration, page 67.** Describes procedures and instructions on how to prepare a PRAESENSA system for configuration.
- **Chapter 7-22: The products.** Introduces each product (category) with detail. Includes functionality, installation and connection instructions and technical specifications.
- **Chapter 23: Application notes, page 281.** Provides notes on challenging installation and system requirements.
- **Chapter 24: Troubleshooting, page 291.** Explains where to find troubleshooting information, and provides a list of known issues and their solutions.
- **Chapter 25: Maintenance and service, page 293.** Provides useful information for maintaining and using your system.
- **Chapter 26: EN 54-16 / EN 54-4 compliance, page 300.** Gives installation and configuration directions for compliance to EN 54-16 and EN 54-4.
- **Chapter 27: ISO 7240-16 / ISO 7240-4 compliance, page 306.** Gives installation and configuration directions for compliance to ISO 7240-16 and ISO 7240-4.
- **Chapter 28: UL 2572 / UL 864 compliance, page 311.** Gives installation and configuration directions for compliance to UL 2572 and UL 864.
- **Chapter 29: DNV-GL type approval, page 314.** Gives installation and configuration directions on vessels for compliance to DNV-GL.
- **Chapter 30: Architects' and engineers' specifications, page 318.** Provides A&E specification details on system and product level.
- **Chapter 31: Tones, page 326.** Gives an overview of the tones the PRAESENSA system offers.
- **Chapter 32: Support and academy, page 335.** Provides (technical) support and training information.

## 2.1 Intended audience

This installation manual is intended for everyone who is authorized to install PRAESENSA and related products.

## 2.2 Training

Participation in the Bosch PRAESENSA product and system training is highly recommended before installing and configuring a PRAESENSA system. The Bosch Security Academy offers classroom training sessions as well as online tutorials on [www.boschsecurity.com](http://www.boschsecurity.com) > Support > Training.

## 2.3 Related documentation

The Bosch PRAESENSA technical documentation is set up in a modular way addressing different stakeholders.

	Installer	System integrator	Operator
Quick installation guide (QIG). Basic step-by-step installations instructions.	X	-	-
Installation manual. Detailed system and product descriptions and installation instructions.	X	X	-
Configuration manual. Detailed instructions for configuration, diagnosis and operation.	X	X	X



### Notice!

Retain all documentation supplied with the products for future reference. Visit [www.boschsecurity.com](http://www.boschsecurity.com) > PRAESENSA product section.

### 2.3.1 Other related documentation

- Commercial brochures
- Architects' & Engineers' specifications (included in the product datasheet)
- Release notes
- Datasheets
- Application notes
- Other PRAESENSA hardware and software related documentation.

Visit [www.boschsecurity.com](http://www.boschsecurity.com) > PRAESENSA product section > System controller > Downloads > Literature.

## 2.4 Listing of open source components

An up to date listing of open source licensed software which may accompany a PRAESENSA device is stored inside the device and can be downloaded as a zip-file. Download instructions are in the Quick Installation Guide (QIG) of the device. This list is also available from [www.boschsecurity.com/xc/en/oss/](http://www.boschsecurity.com/xc/en/oss/).

Each of the components listed may be redistributed under the terms of their respective open source licenses. Notwithstanding any of the terms in the license agreement you may have with Bosch, the terms of such open source license(s) may be applicable to your use of the listed software.



To the extent permitted by applicable law, Bosch and its suppliers make no representations or warranties, express or implied, statutory or otherwise, with regard to the list or its accuracy or completeness, or with respect to any results to be obtained from use or distribution of the list. By using or distributing the list, you agree that in no event shall Bosch be held liable for any special, direct, indirect or consequential damages or any other damages whatsoever resulting from any use or distribution of this list.

## 2.5 **Copyright notice**

Unless otherwise indicated, this publication is the copyright of Bosch Security Systems B.V. All rights are reserved.

## 2.6 **Trademarks**

Throughout this document trademark names may have been used. Rather than put a trademark symbol in every occurrence of a trademark name, Bosch Security Systems states that the names are used only in an editorial fashion and to the benefit of the trademark owner with no intention of infringement of the trademark.

## 2.7 **Notice of liability**

While every effort has been taken to ensure the accuracy of this document, neither Bosch Security Systems nor any of its official representatives shall have any liability to any person or entity with respect to any liability, loss or damage caused or alleged to be caused directly or indirectly by the information contained in this document.

Bosch Security Systems reserves the right to make changes to features and specifications at any time without prior notification in the interest of ongoing product development and improvement.

## 2.8 Document history







Release date	Document version	Reason
2019-11	V1.00	First release.
2020-07	V1.10	Multiple updates.
2021-06	V1.40	Added PRA-ANS. Added PRA-APAS. Multiple updates.
2021-10	V1.41	Added PRA-CSBK. Multiple updates.
2022-06	V1.50	Multiple updates.
2023-08	V1.91	Added PRA-SCS. Added PRA-IM16C8. Multiple updates.
2024-04	V2.00	Added PRA-WCP-EU. Added PRA-WCP-US. Added PRA-CSEK. Update to the PRA-CSLW. Multiple updates.

### 3 System introduction





With PRAESENSA, Bosch has set a new standard in Public Address and Voice Alarm systems. With all system elements being IP-connected and using state-of-the-art technologies, this system combines cost efficiency and audio quality with ease of installation, integration and use. IP-connectivity and amplifier power partitioning enable new levels of scalability and adaptability, and combined with local backup power facilities this makes PRAESENSA equally suited to both centralized and decentralized topologies. PRAESENSA uses only a few different but very flexible system devices, each with unique capabilities, to create sound systems of all sizes for an extremely wide range of applications. PRAESENSA fits to an office with background music in the reception area and some occasional calls, as well as to an international airport with many simultaneous (automated) announcements for flight information, and carefully selected music programs in lounges, restaurants and bars. In all cases, it can be installed to operate also as a certified voice alarm system for mass notification and evacuation. System functions are defined and configured in software and system capabilities can be enhanced via software upgrades. PRAESENSA: one system, endless options.

#### 3.1 Product overview

The following table gives an overview of the available PRAESENSA products. A detailed product description is given by using the link in the "product name" column.

Order number	Product view	Product name
PRA-SCL PRA-SCS		<i>System controller (SCL, SCS), page 75</i>
PRA-LSPRA		License for subsystem PRAESENSA
PRA-AD604		<i>Amplifier, 600W 4-channel (AD604), page 86</i>
PRA-AD608		<i>Amplifier, 600W 8-channel (AD608), page 105</i>
PRA-EOL		<i>End-of-line device (EOL), page 124</i>
PRA-MPS3		<i>Multifunction power supply, large (MPS3), page 132</i>
PRA-ANS		<i>Ambient noise sensor (ANS), page 160</i>

Order number	Product view	Product name
PRA-IM16C8		Control interface module (IM16C8), page 171
PRA-CSLD		LCD call station (CSLD, CSLW), page 185
PRA-CSLW		LCD call station (CSLD, CSLW), page 185
PRA-CSE		Call station extension (CSE), page 200
PRA-CSBK		Call station kit (CSBK), page 210
PRA-CSEK		Call station extension kit (CSEK), page 228
PRA-WCP-EU PRA-WCP-US		Wall control panel (WCP-EU, WCP-US), page 240

Order number	Product view	Product name
PRA-ES8P2S		Ethernet switch (ES8P2S), page 251
PRA-SFPSX PRA-SFPLX		Fiber transceiver (SFPLX, SFPSX), page 260
PRA-APAS		Public Address server (APAS), page 266
PRA-APAL		Advanced public address license
PRA-PSM24 PRA-PSM48		Power supply module (PSM24, PSM48), page 273

Refer to the PRAESENSA Configuration manual for details on the software licenses.

## 3.2 High level system characteristics

### Secure IP-infrastructure

- PRAESENSA is a networked sound system in which all system elements are connected to OMNEO. Built upon multiple technologies, including IP and open public standards, OMNEO supports AES67 and Audinate's Dante for audio communication and AES70 for system control, with additional network security implemented using AES128 and TLS, offering real-time authentication and audio encryption on IP as protection against malicious attacks.
- OMNEO offers a mature, professional-grade media networking solution that provides interoperability, unique features for easier installation, better performance, and greater scalability than any other IP offering on the market.

### Effective power utilization

- PRAESENSA multi-channel power amplifiers have the unique capability of power partitioning, the total power budget of the amplifier can be freely shared across the output channels.
- The class-D amplifier channels operate at high power supply voltages for direct drive 70 V or 100 V outputs without the need for output transformers that would limit the maximum output power of a channel. This also improves efficiency and audio performance and lowers the weight and size of the amplifier. Galvanic isolation of the amplifier outputs, as required by EN 54-16 and other emergency sound standards, is provided by isolated DC/DC converters and the isolated Ethernet connections. The amplifier channels have a load independent, flat frequency response that accept loudspeaker loads between zero and full load. Each channel serves a separate zone or part of a zone.
- The total amount of output power is defined by the redundant power supply and the heatsink, and because both are shared between the amplifier channels, it doesn't matter how many loudspeakers are connected to each channel, as long as the total combined load does not exceed the maximum of 600 W for the whole amplifier and a load > 300 W is not connected to any other channel than channel 1. A spare amplifier channel is also included to take over a failing channel, a very cost- and space-effective redundancy measure because this spare channel uses the same redundant power supply and heatsink too.
- The flexibility of variable output power for each channel makes it possible to utilize most of the available amplifier power. Traditional multi-channel amplifiers have a fixed maximum output power per channel. If a channel is not fully loaded, or even not used, the remaining power capability of that channel cannot be claimed by one of the other channels. PRAESENSA systems typically only need half the amount of amplifier power compared to systems with traditional fixed maximum power amplifiers, saving on space, energy and cost.

### Highest system availability

- PRAESENSA offers the highest system availability due to conservative derating of all components, supervision of all critical signal paths and functions, and built-in redundancy of all critical system elements.  
PRAESENSA devices have high margins for safety and temperature stability. This is illustrated by the fact that PRAESENSA devices are quite unique in that they may be operated at altitudes of up to 5000 m (16404 ft), an important requirement in Peru, Chile, India, China and other countries. At this altitude the air is less dense and the cooling capacity of air is decreased, making heat removal less effective. Also, the

dielectric properties of air change with altitude, decreasing its insulator capabilities. PRAESENSA uses effective heat sinking and significantly increased creepage and clearance distances to maintain safety ratings.

- Dual redundant system controller option for highest system availability in mission-critical applications.
- All system devices use dual Ethernet ports, supporting RSTP, to recover automatically from a broken network link.
- The multifunction power supply offers battery backup facilities to be insensitive to mains failures.
- Amplifiers have an integrated spare amplifier channel to take over from a failing channel automatically. They also have double power supplies built in, working in tandem to minimize stress on components, while each one is capable of supplying full power to the amplifier if one section would fail.
- The amplifiers have two loudspeaker outputs per channel, group A and B, separately supervised and protected, to support connection of interleaving loudspeaker strings in the same zone, so a shorted or interrupted loudspeaker line will not mute that zone completely.

#### **Optimized user experience**

- The PRAESENSA call stations provide a combination of a large touch screen LCD with mechanical buttons and LED indicators. Access to system functions and areas can be configured per call station, to provide exactly the functions the operator needs, not more, not less. The user interface has been developed in cooperation with real users and addresses their needs, but also their discomforts when making calls to zones they can't see or hear, or adjusting the volume of background music in these areas.
- Functions are easily selected from the touch screen, and zones are easily selected via keypad keys with LEDs giving immediate feedback on the actual status of that zone. After starting a call, the screen shows the operator the progress of the call, indicating when to speak after a start tone or automatic introduction message has finished, and showing whether the call was successfully completed in all destinations.

#### **Fully-featured as standard**

- PRAESENSA is an advanced system for Public Address and Voice Alarm purposes. The system consists of a limited range of hardware devices in combination with software to create the required functions. Because the hardware devices are very complete and flexible to use, only a few different devices are sufficient to create a system. For instance, all call stations and amplifiers have a built-in DSP for sound processing, the amplifiers have flexible output power per channel and a built-in spare channel, the power supply has a built-in battery charger, and so on. No need for separate add-ons.
- System functions are software based and regularly updates become available to extend the set of capabilities.

#### **Scalable and flexible**

- PRAESENSA is an extremely scalable and flexible system. All devices are network connected and offer loop-through connectivity for easy system expansion and RSTP to create a fail-safe network loop. System devices can be decentralized and their redundant loop wiring often allows for cheap non fire-resistant network cables to be used.
- PRAESENSA uses dynamic channel allocation. Because devices do not use static routing, amplifiers and call stations do not have a permanent audio connection to the system controller. That approach would limit the number of devices, since an 8-channel amplifier would at least need 8 connections, 100 amplifiers would need 800

connections to be independent. Instead, PRAESENSA uses dynamic OMNEO connections that are generated on the fly when needed and freed up after use. Dynamic streams occupy the least bandwidth; if there is no audio transport going on, the channels are simply not there. Furthermore, this is a scalable solution compared to static channels, which are limited to the number of interconnections that can be handled by the device that contains the audio matrix. All OMNEO audio streams are set up as multicast, directly from the source (the transmitting device, such as a call station) to the destinations (the receiving devices, such as amplifier channels). This connection is setup by the system controller using OCA (AES70). The audio matrix is in the network itself, not in a single unit. In this way, there is no real limitation on the number of source and destination devices. The only limitation is on the number of simultaneous (different) audio streams, which is above 100 and more than enough for even the busiest applications.

- Multifunction power supplies have an integrated battery charger for single 12 V battery based backup power, facilitating easy system decentralization. Amplifiers can be placed closer to the loudspeakers, reducing loudspeaker cabling costs, which is especially advantageous in case of expensive fire-resistant loudspeaker cables.
- DSP power is available in all call stations and amplifiers, so DSP power grows with every device added to the system.
- Every zone has its own amplifier channel for dedicated audio content. Users can make personal music and volume selections, while announcement levels are not affected and loudspeaker line supervision is not impaired. The amplifier's built-in DSP allows the sound in each zone to be adjusted to the needs and taste of the audience in that area.
- The complexities of traditional system planning make little room for error or last-minute changes. With PRAESENSA however, flexibility is built-in, allowing for an agile and adaptive approach to planning. PRAESENSA allows for future changes to the areas covered by the system, with minimal or no equipment changes. Thus, initial planning is less sensitive to later small changes, which could impact profitability.



## 4 General installation procedures and instructions

This section provides mounting and installation instructions common to all PRAESENSA devices. It provides installation methods commonly encountered in industrial and commercial applications and should be used in conjunction with the engineer's installation specifications and all applicable codes.

**Caution!**

All work activities necessary for the installation, connection and commissioning are to be carried out by electrically skilled persons only.

### 4.1 Location of racks and enclosures

The Bosch PRAESENSA VACIE (Voice Alarm Control and Indicating Equipment) system is designed to provide an emergency announcement and public address system in accordance with the requirements of international standards. The PRAESENSA VACIE includes control and indicator equipment, multi-channel amplifiers, multifunction power supplies, network infrastructure and optional emergency call stations.

In order to ensure that the standards compliance of the PRAESENSA VACIE is not compromised, the PRAESENSA devices, the interconnections to the Fire Detection System, network infrastructure, loudspeakers and loudspeaker wiring must be installed in accordance with the provisions of applicable standards and the directions provided in this Bosch PRAESENSA installation manual.

The Bosch PRAESENSA VACIE must be installed and commissioned by those who have completed the appropriate training courses conducted by Bosch Security Systems. Once the installation and commissioning process is complete, access to the VACIE is restricted to authorized personnel only, in accordance with the access levels indicated in the following table.

**Caution!**

Also in case the PRAESENSA system is not being used as VACIE and the corresponding access restrictions are not applicable, the system controller, amplifiers and power supplies (19"-equipment) should be installed in a Restricted Access Area only. Especially children may not get access to this equipment.

**Caution!**

The system shall not be installed near water or heat sources.

**Caution!**

System power supplies shall be connected to a mains power outlet socket with a protective earthing connection. An external, readily operable, mains plug or all pole mains switch shall be installed.

Level	Authorized operations	Authorized persons	Access restrictions
Level 1	<ul style="list-style-type: none"> <li>– Accessibility to all mandatory visible and audible indications</li> <li>– System operation for business calls and background music</li> </ul>	Members of the general public	Unrestricted, such as <ul style="list-style-type: none"> <li>– Desktop call station in public area</li> <li>– Wall-mounted background music control panels in public zone</li> </ul>
Level 2	<ul style="list-style-type: none"> <li>– Level 1 operations</li> <li>– System operation in the:               <ul style="list-style-type: none"> <li>– Quiescent condition</li> <li>– Voice alarm condition</li> <li>– Fault warning condition</li> <li>– Disabled condition</li> <li>– Test condition</li> </ul> </li> </ul>	Persons with specific responsibility for safety, competent and authorized to operate the system	Restricted by a special procedure, such as <ul style="list-style-type: none"> <li>– Operator panel mounted in an enclosure with lockable door</li> </ul>
Level 3	<ul style="list-style-type: none"> <li>– Level 2 operations</li> <li>– Re-configuration of site-specific data</li> <li>– System maintenance</li> </ul>	Persons with specific responsibility for system maintenance, competent and authorized	Restricted by a special procedure, differing from that for access level 2, such as <ul style="list-style-type: none"> <li>– Configuration program with password protection</li> <li>– System is mounted in a 19"-rack with lockable doors</li> </ul>
Level 4	<ul style="list-style-type: none"> <li>– Level 3 operations</li> <li>– System repair</li> <li>– Perform firmware alterations, thereby changing the basic mode of operation</li> </ul>	Persons with specific responsibility for system repair, competent and authorized by the manufacturer	Restricted by special means, not part of the VACIE, such as <ul style="list-style-type: none"> <li>– Dedicated firmware upgrade program with password protection</li> <li>– Dedicated tools</li> </ul>

The PRAESENSA VACIE, consisting of PRAESENSA devices and associated support devices and optional batteries, is typically housed in one or more free-standing or wall-mounted rack cabinets. These cabinets can be at one central location or decentralized, servicing a larger area. PRAESENSA end-of-line devices, used for loudspeaker line supervision are mounted at appropriate locations, in accordance with the directions provided in this manual.

To ensure correct operation, the installer needs to ascertain that access level requirements are met. To maintain standards compliance, installers must follow the Bosch installer guidelines.

**To achieve the specified access level 2:**

- Access to the emergency microphone is restricted by mounting the microphone in a lockable enclosure or control room.

**To achieve the specified access level 3:**

- The cabinets must be located in lockable rooms, or a cabinet construction with lockable doors must limit access to rear terminals and wiring of equipment.
- Access to end-of-line supervision devices and loudspeaker wiring terminals requires the use of tools.

## 4.2 Unpacking products

The products should be unpacked and handled with care. If an item appears to be damaged, notify the shipper immediately. If any items are missing, notify your Bosch representative. The original packaging is the safest container in which to transport products and can also be used to return products for service, if necessary.

## 4.3 Equipment racks and cabinets

All PRAESENSA equipment housings are of robust construction and meet at least classification IP30 of EN 60529:1992 as amended by EN 60529:1991/A1:2000. Racks with a swing frame give better access to wiring. Racks without rear stands provide more space for batteries.

## 4.4 Mounting the 19"-rack devices

Common installation materials and tools are sufficient to install PRAESENSA products. Each product comes with a set of product specific installation accessories and a quick installation guide (QIG).

Make sure the 19"-equipment rack is of suitable quality to support the weight of the device(s).

All PRAESENSA equipment can be located anywhere in the equipment rack. For ease of wiring, it is however advisable to mount devices in the following order (top to bottom):

- System controller (top)
- Amplifiers
- Multifunction power supplies
- Batteries (bottom)



As long as the equipment rack is well ventilated, all devices can be stacked with no extra space between them. Make sure the temperature inside the rack cannot exceed +50 °C (+122 °F).

- *Mounting brackets* are used to mount the device in 19"-equipment racks.
- *Ventilation inlets* should be kept free of obstacles and dust. Fans are controlling the airflow based on internal temperature. Airflow is from the front to the rear and sides.
- *Integrated handles* make it easy to maneuver the device, without adding to the installation depth.
- *Sliding feet* prevent making scratches on the surface the device is positioned on.
- *Product labels* are on the side or rear of each device.

### Notice!



Make pictures of the product labels and make sure the hostnames and MAC-addresses are readable, or make a list of all hostnames and MAC-addresses of the devices before mounting them in the rack. This information is needed for configuration later. After mounting, access to the product labels with this information might be difficult, especially for devices that have their labels on the side.

The mechanical construction of all 19"-devices is rigid enough to mount the devices using only the holes in the mounting brackets to secure them in the rack. It is however considered good practice to mount support rails if the system is installed in a moving environment.

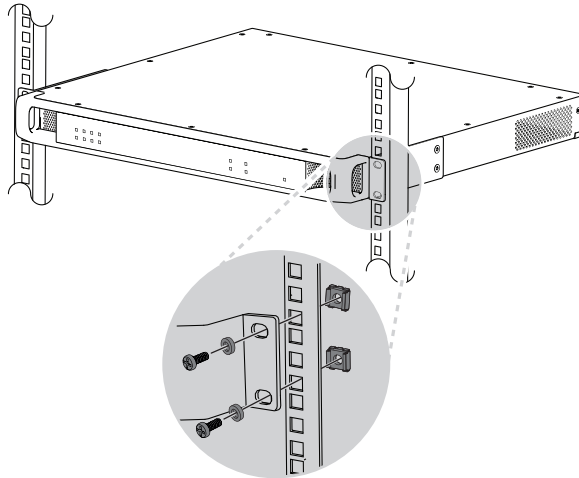

The PRAESENSA 19"-devices are equipped with (removable) mounting brackets for mounting in a 19"-rack. Use four caged nuts, nylon cup washers and pan head bolts for mounting. Common sizes for bolts and nuts for rack mounting are M6, M8, 10-32 or 12-24.



#### Caution!

The rack must be grounded to a safety ground. All PRAESENSA 19"-devices have a chassis ground screw on the rear panel, which can be used for a wire connection to the rack frame. Use a thick, multi-strand wire (>2.5 mm<sup>2</sup>) with wire eyelets and washers for a solid connection. This connection is mandatory for the PRA-AD604 and PRA-AD608 as a reference for ground-short detection and because of high internal voltages, but may improve immunity to electrostatic discharges (ESD) for all devices.

## 4.5 Cable requirements

To ensure safety and system reliability, different types of cabling are required for cabling inside the racks that house PRAESENSA devices, and for cabling between racks and to ancillary items such as loudspeakers.

### 4.5.1 Precautions

#### Prior to installation

Confirm the following:

- The cable selected is proper for the application, taking into account all applicable local, state, provincial, and national codes.
- The cable has not been damaged in transit or storage.

#### During cable installation

The following factors must be considered:

- Do not exceed the fill capacity of raceways and cable trays.
- Use grommets to protect cables when passing through metal studs or anything that can possibly cause damage.
- Obey bending rules of cables and maximum pull force.
- Be sure to firestop all cables that penetrate a firewall.
- Use plenum rated cable where it is mandated.
- Use fire resistant cable when it is mandated.

## 4.5.2

### Cable type recommendations

#### Mains cable

- Use the supplied mains cable that came with the multifunction power supply or an equivalent.

#### Loudspeaker cable

- When selecting cables and wire gauge take into account the length and loudspeaker load to avoid excessive power loss. Make sure that the signal level at the end of the loudspeaker line has not dropped with more than 2 dB (this is approximately 20%), as this will also affect proper operation of the end-of-line device.

The table shows the required wire size for copper wires, to keep the loss at the end of the loudspeaker line below 2 dB, when all the load is at the end of the cable. In practice the load will be more distributed and then the attenuation will be less than 2 dB. Round up the actual load power and cable length to the next number in the table. Copper clad aluminum (CCA) wires are cheaper but have a higher resistance than copper for the same diameter. When using CCA cables, take the next bigger wire size from the table. **Examples:**

- A 150 W loudspeaker load on a loudspeaker line of 480 m in a 100 V system. Round up to table values 200 W and 500 m. This requires 1.5 mm<sup>2</sup> copper wires or 2.5 mm<sup>2</sup> CCA wires.
- A 150 W loudspeaker load on a 1200 ft loudspeaker line in a 70 V system. Round up to table values 150 W and 1312 ft. This requires AWG 14 copper wires or AWG 12 CCA wires.
- When selecting cables and wire gauge take into account the maximum loudspeaker cable capacitance specified for the amplifier.
- When end-of-line supervision is used, take into account the maximum loudspeaker cable capacitance specified for the end-of-line device.
- For compliance to UL 62368-1 all loudspeaker wiring must be Class 2 (CL2); this requirement does not apply for compliance to EN/IEC 62368-1.

Conversion									
<b>mm<sup>2</sup></b>	0.5	0.75	1	1.5	2.5	4	6	10	16
<b>AWG</b>	20	18	17	16	14	12	10	8	6

Cable length		Minimum wire cross section [mm <sup>2</sup> ]								
[m]	[ft]									
1000	3280	0.5	0.75	1.5	4	6	6	10	10	16
900	2952	0.5	0.75	1.5	2.5	4	6	10	10	10
800	2624	0.5	0.75	1.5	2.5	4	6	6	10	10
700	2296	0.5	0.5	1	2.5	4	4	6	6	10
600	1968	0.5	0.5	1	2.5	2.5	4	6	6	10
500	1640	0.5	0.5	0.75	1.5	2.5	4	4	6	6
400	1312	0.5	0.5	0.75	1.5	2.5	2.5	4	4	6
300	984	0.5	0.5	0.5	1	1.5	2.5	2.5	2.5	4
250	820	0.5	0.5	0.5	0.75	1.5	1.5	2.5	2.5	4
200	656	0.5	0.5	0.5	0.75	1	1.5	1.5	2.5	4
150	492	0.5	0.5	0.5	0.5	0.75	1	1.5	1.5	2.5
100	328	0.5	0.5	0.5	0.5	0.5	0.75	0.75	1	1.5
50	164	0.5	0.5	0.5	0.5	0.5	0.5	0.5	0.5	0.75
[W]	@100 V	20	50	100	200	300	400	500	600	-
[W]	@70 V	10	25	50	100	150	200	250	300	400
<b>Loudspeaker power at end-of-line</b>										

**Ethernet copper cable**

The table below shows the common types of Ethernet cables. The unshielded U/UTP cable is the most common. You can use it for less critical applications. All other cable variants have some sort of shielding. The shielding inside the cable acts as a barrier to:

- Protect the cable from electromagnetic interference (EMI).
- Protect the cable from radio frequency interference (RFI).
- Protect the cable from crosstalk between pairs and adjacent cables.
- Prevents the signal from the cable from interfering with the surrounding equipment.

The various levels of shielding offer a range of different advantages suitable for several applications.

Name (IEC 11801)	Cable shielding	Twisted pair shielding	Cable description
U/UTP	None	None	Also known as UTP, it is currently the most common and basic method of cable construction. This type of cable consists of pairs of wires twisted together. Without shielding, the symmetrical twist in the wires creates a balanced transmission line, which helps to reduce the electrical noise and EMI.

			In addition, the different twist rates of each pair are used to reduce crosstalk. In higher category cables, a cross-web filler might be found to separate the individual pairs. This filler helps to reduce alien crosstalk from adjacent cables.
F/UTP	Foil	None	Often referred to as FTP. This type of cable features an overall foil shield wrapped around unshielded twisted pairs and a drain wire. When the drain wire is correctly connected, unwanted noise is redirected to the ground. This offers extra protection against EMI and RFI.
S/UTP	Braiding	None	This type of cable features an overall braid screen with unshielded twisted pairs. S/UTP supports higher transmission rates across longer distances in comparison with U/UTP. It provides better mechanical strength and grounding due to the braid.
SF/UTP	Braiding + Foil	None	This type of cable features an overall braid shield and a foil shield with unshielded twisted pairs. SF/UTP offers effective protection from EMI, both from the cable and into the cable. It also provides much better grounding due to the additional braid.
F/FTP	Foil	Foil	This type of cable features an overall foil shield with individually foil tape shielded twisted pairs. F/FTP is similar to the F/UTP cable, with an additional foil shield around each twisted pair. The cable construction provides greater protection from crosstalk from adjacent pairs and other cables, RFI and EMI.
S/FTP	Braiding	Foil	Like with F/FTP, the individual twisted pairs are wrapped in a foil tape, and wrapped again in an overall flexible yet mechanically strong braid screen. The additional foil on the twisted pairs helps to reduce crosstalk from adjacent pairs and other cables. The braid provides better grounding.
SF/FTP	Braiding + Foil	Foil	This type of cable has both an overall braid shield and foil shield, with individually foil tape screened twisted pairs. SF/FTP offers the maximum protection from RFI, EMI, crosstalk and alien crosstalk. It also provides



			the best level of protection from interference, as well as better grounding due to the braid.
--	--	--	---

**Notice!**

Use shielded twisted pair cabling instead of ordinary unshielded twisted pair cabling (U/UTP) to comply with the strict rules regarding resilience to high-energy voltage surges on the Ethernet connections. The shielding is required to comply with:

- the EMC requirements of EN 50130-4 for Voice Alarm systems
- EN 50121-4 for Railway applications
- EN 55024 for IT equipment and EN 55035 for Multimedia equipment regarding the immunity to slow surges.

For PRAESENSA, use shielded cables. F/UTP is the cheapest and its performance is sufficient. The picture shows such an F/UTP cable. You can also use the next cable types in the table, which offer increasingly better protection.

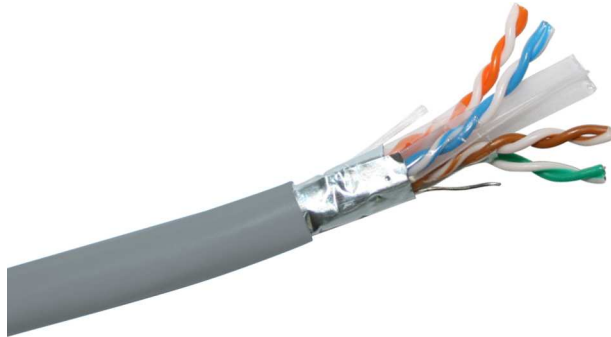

- All PRAESENSA devices are designed to be used with Gigabit transmission (1000BASE-T). Although shielded CAT5e cables might be sufficient, use CAT6A F/UTP cables. According to their specifications, these cables can transmit data up to 100 m, but the actual potential transmission distance varies depending on factors such as the cable and termination quality and the environment in which the cable is used. Furthermore, cables can be categorized into solid core cables and stranded cables according to the structure of the conductors within the cables. In a solid core cable each of the eight conductors consists of a single copper wire, while in a stranded cable each conductor consists of stranded multiple copper wires. Solid core cables have better transmission performance over long distances than stranded cables. Stranded cables are more flexible and easier to handle than solid core cables. Therefore, in general, solid core cables are suited for installations, while stranded cables are suited for short patch links inside racks.
- Make only gradual bends in the cable where necessary to maintain the minimum bend radius of 4 times the cable diameter. Never allow the cable to be sharply bent, twisted, or kinked at any time. This can cause permanent damage to the geometry of the cable and cause transmission failures.
- Dress the cables neatly with cable ties. Use low to moderate pressure.

**Ethernet glass fiber cable**

- Use single mode or multi-mode glass fiber that fits the SFP transceiver.
- The length of the fiber must not exceed the maximum as specified for the SFP transceiver, also considering the fiber diameter.

- Keep all food and beverages out of the work area. If fiber particles are ingested they can cause internal hemorrhaging.
- Wear disposable aprons to minimize fiber particles on your clothing. Fiber particles on your clothing can later get into food, drinks, and/or be ingested by other means.
- Always wear safety glasses with side shields and protective gloves. Treat fiber optic splinters the same as you would treat glass splinters.
- Never look directly into the end of fiber cables until you are positive that there is no light source at the other end. An SX fiber 850 nm light source is hardly visible, an LX fiber 1310 nm light source is not visible at all.
- Do not touch your eyes while working with fiber optic systems until your hands have been thoroughly washed.
- Put all cut fiber pieces in a properly marked container for disposal.
- Thoroughly clean your work area when you are done.

## 4.6 Network requirements and considerations

PRAESENSA uses technologies built on top of standard Ethernet networks and the performance of PRAESENSA is heavily reliant on the network configured underneath it. As a result, the underlying network needs to be configured correctly. If the network is not functioning properly, the audio equipment will not function properly either. Because all PRAESENSA devices have integrated Ethernet switches, a system can be set up without being dependent on third party network infrastructure. In many situations, however, PRAESENSA may have to share the network with other services, especially on existing network infrastructure. Although most Gigabit networking equipment will adequately support PRAESENSA, certain configurations that may be present in an enterprise network could cause issues. In any case it is appropriate to consult the IT department when planning and configuring a PRAESENSA network, taking the following network considerations into account.

### 4.6.1 Network topology

PRAESENSA offers great flexibility to position its networked devices across the premises. This allows for a conventional centralized system topology, with most of the equipment in a central 19"-rack in a technical room. But it is as easy to position equipment in smaller clusters on different locations in order to keep loudspeaker lines short, saving on cost and reducing power losses in the loudspeaker cabling. This is especially beneficial when expensive fire-resistant cables must be used. Because all system elements are network connected and can be powered from a multifunction power supply with local battery backup power, a decentralized system topology is easier than ever before. Call stations, positioned at operator locations, are also network connected and even powered over Ethernet.

### 4.6.2 Network connector ports

The system controller has five external RJ45 network ports and acts as the root switch for the network, supporting multiple loops.

The multifunction power supply has five external RJ45 network ports and one socket for a Small Form-factor Pluggable (SFP) transceiver module for a single mode or multi-mode optical fiber connection, to facilitate long distance connections between decentralized clusters of devices. Two of the RJ45 network ports provide Power over Ethernet (PoE) to power a connected call station.

Each call station has two RJ45 network connectors, each capable of taking PoE-power, to connect to one or two different power supplies, to allow for fail-safe redundancy. Because of PoE, connecting call stations in a loop-through fashion is only possible with a PoE power source in between, e.g. a midspan PoE power adapter.

### 4.6.3 Audio content and device control

PRAESENSA uses OMNEO network technology. OMNEO is an architectural approach to connecting devices that need to exchange information such as audio content or device control. Built upon multiple technologies, including IP and open public standards, OMNEO supports the technologies of today such as Audinate's Dante while adopting the standards of tomorrow, such as AES67 and AES70. OMNEO offers a professional-grade media networking solution that provides interoperability, unique features for easier installation, better performance and greater scalability than any other IP offering on the market. Using standard Ethernet networking, media products that integrate OMNEO can be assembled into small, medium and large networks that exchange studio-quality synchronized multichannel audio and share common control systems. OMNEO's media transport technology is based on Audinate's Dante, a high performance standards-based, routable IP-media transport system. OMNEO's system control technology is AES70, also known as Open Control Architecture (OCA), an open public standard for control and monitoring of professional media network environments. OMNEO devices are fully compatible with AES67 and AES70, without losing any functionality.

### 4.6.4 Network security

The OMNEO network technology includes two types of security:

- Control security, using encryption and authentication of the TCP (OCA) control data.
- Audio security, using encryption and authentication of the audio streams.

Control security is realized via Transport Layer Security (TLS). This mechanism requires a TCP-link and a Pre-Shared Key (PSK). The PSK has to be present on a device before it is possible to start a secure connection with that device. OMNEO uses the Diffie-Hellman key exchange method to allow two parties that have no prior knowledge of each other to jointly establish a shared secret key over an insecure channel. This key can then be used to encrypt subsequent communications. This solution comes with a short period of vulnerability when the factory default key is changed to a system-specific key. At that moment attackers can learn the system key by eavesdropping the Diffie-Hellman key exchange during the connection setup with the factory default key. Preferably, this part of the setup should be done on a closed network. The PSK is stored persistently in the device. To change the PSK later, the key must be known. When the key is lost and/or devices are transferred from one system to another system, a manual reset switch allows a device to be reset to its factory default. This requires physical access to the device.

The Cipher suite used by OMNEO is TLS\_DHE\_PSK\_WITH\_AES\_128\_CBC\_SHA. This means:

- Encryption 128 AES.
- Authentication and data integrity HMAC-SHA-1.

Audio security uses a proprietary implementation of a standards based algorithm for encryption and authentication. The main reason for this is the required low latency, it only adds 0.1 ms additional sample delay for encoding plus decoding. It uses 128 AES encryption in Cipher Feedback Mode (CFB) for self-synchronization, even when the audio stream is received much later than when it was started, or when some samples are lost during reception. Only six audio samples (125 us @ 48 kHz sample rate) are sufficient to re-synchronize.

For authentication the algorithm uses Cipher-based Mandatory Access Control, CMAC. This adds eight bits to each 24-bit audio sample, resulting in 32-bit samples.

The audio security algorithm uses a Pre-Shared Key that has to be equal for the transmitter and receiver. The key is volatily stored on the device and is lost after a power cycle, so it must be redistributed via a secure control connection. A random key is defined every time an audio connection is created, so each audio link has a different key.

Other security measures in PRAESENSA are:

- The system controller stores passwords and exchanges passwords with the Open Interface / API clients using the SHA-2 Secure Hash Algorithm (version SHA-256).
- Configuration and message backup is possible over an authenticated secure connection (HTTPS) based on Transport Layer Security (configurable TLS1.2 or TLS 1.3).

#### 4.6.5 Network speed and bandwidth usage

PRAESENSA uses the OMNEO protocol for audio and control, with all audio streams based on 48 kHz sample rate and 24-bit sample size. Because of encryption for security, 32-bits per sample are used. By default the receiver latency is set to 10 ms as a compromise between latency and network efficiency. This combination of parameters causes a bandwidth usage of 2.44 Mbps per (multicast) channel in the whole subnet it is used in. Control traffic will add another 1 to 20 Mbps, depending on system size and activities. A Gb Ethernet network is needed for OMNEO. This is not necessarily a bandwidth requirement of multiple concurrent audio channels. Even if only a few audio channels are in use, a Gb network backbone is needed to support the Precision Time Protocol (PTP) for synchronization of all audio devices (IEEE 1588 and IEC 61588). Packet arrival jitter is a critical parameter, which is the variation in latency between the reception of multiple Ethernet messages from the same source. Because of this, Ethernet packet switching must be done in hardware, as software switches will introduce too much jitter. PRAESENSA devices are pre-configured to use Quality of Service (QoS) prioritization for OMNEO, with carefully selected parameters. Other switches need to be configured with the proper settings for OMNEO.

#### 4.6.6 System size limits

OMNEO always uses synchronized play-out times to make sure every receiver produces the audio at exactly the same moment (with an accuracy of 1 us). The maximum distance between two networked devices on the network depends on the configured latency of the receivers. By default PRAESENSA uses a receiver latency setting of 10 ms, which allows for a maximum distance between two devices in the same subnet of 500 km. The OMNEO technology allows for a maximum receiver latency of 20 ms, which is sufficient to cover a distance of 3000 km between devices (not yet supported by PRAESENSA).

If the distance between a transmitter and a receiver is too long for the configured receiver latency, then the audio samples arrive at the receiver later than the instructed play-out time. Then the samples cannot be used anymore, resulting in no audio.

There also exists a practical limit to the number of devices that can be connected in a PRAESENSA system, combined with a maximum number of addressable zones. These limits relate to the response time of the system when a call is made. Before a call can be started from a call station to its selected zones, all affected amplifier channels must switch to the OMNEO audio channel that is assigned for that call. This switch takes some time, and the call station operator cannot start speaking before the routing to the amplifiers is set up. The setup time for an overruling call can be approximately calculated by the formula

$t = 0.03 \times D^2 + 1.8 \times Z + 400$  [ms], in which D is the number of affected devices and Z is the number of affected zones. The setup time can also be visualized in a graph for the setup time of call.

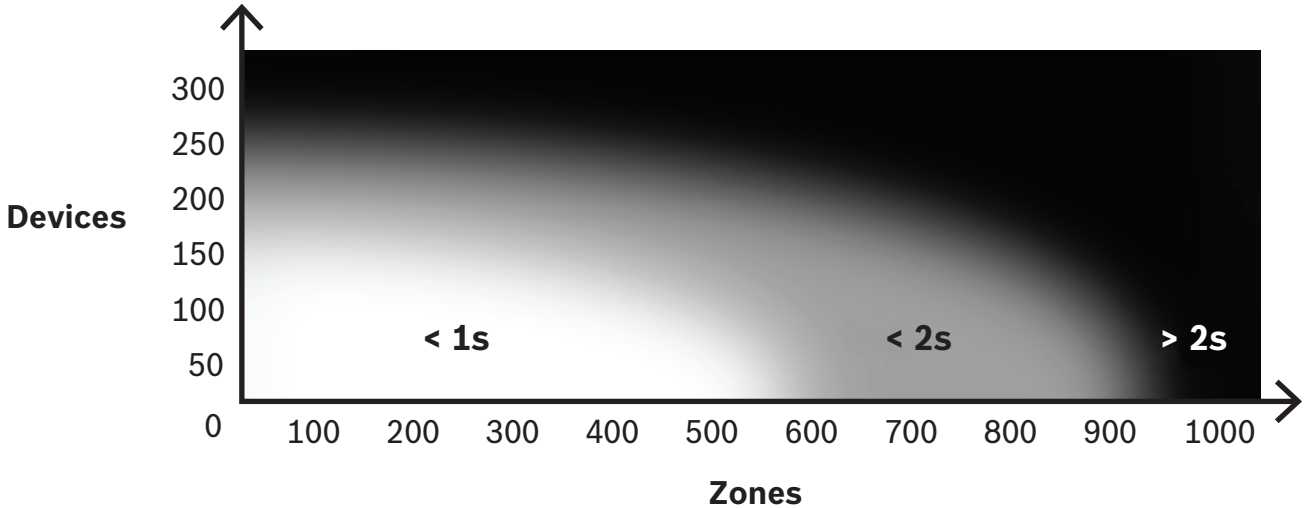

The maximum number of PRAESENSA network devices in one subnet of a system is approximately 250 devices. For a smooth and fast operation of the system, it is recommended to limit the system size to 150 devices, but this depends on the number of addressable zones. The number of zones in this graph represents the number of zones that are selected for the call, not the zones that are in the system. The system can have more zones. When these zones are not part of a call, they do not contribute to the setup time of that call. An “All-call” is the most time consuming.

**4.6.7 Network switches**

All networked PRAESENSA devices have a built in Ethernet switch with at least two Ethernet ports on RJ45, supporting Rapid Spanning Tree Protocol (RSTP). Because of the integrated switches, stacked devices can be looped through conveniently with short cables. For RSTP-support, cable loops are allowed in the network, creating redundant connections for automatic network recovery when a connection would fail. This is an important consideration for emergency sound systems. No conventional star-wiring is needed, although it is possible. A PRAESENSA network can be expanded easily by inserting more devices in the loop or chain.

Not all Ethernet switches can be used for PRAESENSA (or any other system that is based on Audio over IP). As part of the PRAESENSA product range a pre-configured, managed, multi-port Ethernet switch is available for more connection flexibility. This switch is also included in the PRAESENSA certification for EN 54-16 and other standards.

In case other switches or routers are to be used, consider the following important requirements:

- The switch must be a Gb-switch with packet switching performed in hardware; software switches will introduce too much jitter.
- The MAC-address table must have a capacity of >1000 addresses, to prevent that the switch starts broadcasting unicast packets because it runs out of space.
- The switch must support Quality of Service (QoS), with strict priority, through differentiated services (DiffServ) on all ports, to ensure that PTP-synchronization and audio packets get priority over control packets.

- Do not use Energy Efficient Ethernet (EEE) for PRAESENSA because this breaks the PTP synchronization, resulting in poor audio synchronization performance and occasional dropouts. EEE is a technology that reduces switch power consumption during periods of low network traffic. It is also known as ‘Green Ethernet’ and IEEE 802.3az. The PRAESENSA system controller and multifunction power supply have integrated switches, but when additional switches are needed, it is recommended to use PRAESENSA managed switches. Otherwise, do not use unmanaged Ethernet switches that support the EEE function, since EEE operation cannot be disabled in these switches. For managed switches, ensure that they allow EEE to be disabled and make sure that EEE is disabled on all ports used for PRAESENSA audio traffic. Guidelines for selecting switches are found on the Audinate website at the following link: <https://www.audinate.com/resources/networks-switches>
- Because PRAESENSA uses the Rapid Spanning Tree Protocol (RSTP) for network connection redundancy, the switch must support RSTP (IEEE 802.1D-2004) with the ability to change the following parameters, which must be set to the following (not default) values: Hello\_time = 9 s, Forwarding\_delay = 30 s, Max\_age = 22 s. Make sure that **not more than 21** devices are between the root bridge and any other device. The 22<sup>nd</sup> and further devices will not communicate anymore. This means that a loop of 43 devices may work fine, but when the loop breaks, all devices after the 21<sup>st</sup> device are lost.
- The switch must support the Link Layer Discovery Protocol (LLDP, IEEE 802.1AB) and LLDP must be enabled. LLDP is a vendor-neutral configuration exchange protocol for Layer 2 discovery based on the IEEE 802.1ab standard. This protocol allows a device to advertise information such as its identity or capabilities to its neighbor. PRAESENSA uses LLDP for network supervision. The Docent network diagnose tool also requires LLDP.
- PRAESENSA uses Internet Group Management Protocol (IGMP), the communication protocol responsible for communication between the end devices (hosts) and the switch or router. It is used for dynamic multicasting between one source and a selected group of destinations by establishing multicast group memberships. For switches that offer the possibility of IGMP snooping, it is strongly recommended to disable this feature. Performance limitations of the switch while snooping many simultaneous IGMP messages may cause some messages to be dropped, resulting in no multicast audio being present on the requesting port. Especially when using daisy-chained devices this will be a problem.
- PRAESENSA supports multi-subnet networks. The minimum L3 requirements for a router are:
  - 1 Gbit or higher Ethernet ports
  - Supports PIM-DM (Protocol Independent Multicast - Dense Mode) or Bidirectional PIM
  - Performs IP-routing in hardware (a Layer 3 switch) to minimize routing delay
  - Has a packet forwarding rate of >1,000,000 packets per second per port (for example, 8 Mpps for an 8-port router)
  - Has non-blocking backplane per switching port, such as 2 Gbps per port (for example 16 Gbps for an 8-port router)
  - Has a MAC address table of at least 1000 addresses per directly connected subnet.

### 4.6.8 Setting up connections

The PRAESENSA system controller manages all dynamic OMNEO channels between PRAESENSA devices. The software program OMNEO Control is not needed to set up OMNEO channels.

To set up static Dante channels from Dante sources to the PRAESENSA system controller, use Dante Controller from Audinate. These static channels will be persistent, i.e. are automatically restored after the Dante source has been switched off and on again.

### 4.6.9 Network redundancy

Dante supports so-called glitch-free audio redundancy. This is a failover protection mechanism ensuring audio is resistant to network failure. To achieve glitch-free audio redundancy an entirely redundant network structure is required, doubling the network and the installed network components, with dual Ethernet connections on separate subnets. However, to have glitch-free redundant audio, you cannot conveniently daisy-chain units across the subnet. Audio is sent and received on all the connections, eliminating the possibility of connections to other devices in a chain. If one connection is lost, the audio stream is still received through the second connection, meaning no audio information is lost.

An important restriction of this mechanism is that it only works for audio; the transmission of control information is not redundant! Therefore, in the event of failover, audio continues to play, but settings cannot be changed until the primary link has been repaired. This makes glitch-free audio redundancy unsuitable for PRAESENSA, that continuously uses control information between devices for monitoring and call processing.

PRAESENSA uses RSTP to create redundancy. This is not glitch-free, audio will be muted for a short period of time until the network has recovered from a broken link, but it works for both audio and control data. Also, it allows for loop-through connections, so devices can be daisy-chained.

For static Dante audio input streams, the PRAESENSA system controller does support glitch-free audio redundancy. This is possible because these Dante sources are not controlled by the system controller. To use this feature, the primary network must be connected to one of the ports 1 to 4 of the system controller, the secondary network must be connected to port 5. The Dante connections must be set up using Dante Controller software.



#### Notice!

1000BASE-T Ethernet connections use all four wire pairs in a standard CAT6A F/UTP cable, while 100BASE-TX uses only two pairs. Most Ethernet switches have a feature that a 1000BASE-T port falls back to 100BASE-TX when a connected cable has a fault of some sort in any of its eight wires. In a system that uses RSTP for cable redundancy, disable this fallback feature, because a 100 Mbps connection is still considered a valid connection and RSTP does not replace it with an alternative high speed 1 Gbps-link. In all PRAESENSA devices, this fallback mechanism is disabled to allow RSTP to work properly.

### 4.6.10 IP-addressing

An Internet Protocol (IP) address is a unique address which identifies hardware over the network such as a computer, server, system controller, switch, call station or amplifier. It allows a device to communicate with other devices over an IP-based network such as the LAN or WAN. There are multiple possibilities for assigning an IP-address to a device: Link-Local, DHCP and manual (static) assignment:

- **Link-Local** addresses are automatically assigned by the individual devices in cases where no static IP-addressing is assigned and a DHCP-server is not found (IPv4LL). Addressing is based on the MAC-address of the device. Link-Local addressing can be recognized by an IP-address within the range of 169.254.0.0/16 (169.254.0.1 - 169.254.255.254) with subnet-mask 255.255.0.0. Do not use 255.255.255.0 as subnet-mask! This Link-Local addressing is also known as Automatic Private IP-Addressing (APIPA-addressing). The Link-Local addressing scheme manages fixed IP-addresses in the same range, as the devices automatically check availability of the IP-address to ensure devices that do not support IPv4LL can operate in the same subnet. IPv4LL addressing only supports a single subnet; this IP-address range is not routable, so will be dropped by a router.
- **Dynamic Host Configuration Protocol** (DHCP) is a technology used to assign IP-addresses and other related configuration information (such as subnet mask and default gateway) automatically to each device on a network. This is achieved by using a device that contains a DHCP-server, a feature frequently found in devices such as routers or an ARNI. As long as all devices are within the same subnet, IPv4LL is the preferred way of address assignment. When using DHCP, make sure the DHCP-server is powerful enough, because all devices will request an address immediately after the system switches on.
- **Manually assigned IP-addresses**, also known as static or fixed IP-address allocation, are only recommended in the cases where:
  - You have a good understanding of the network administration, and
  - Assigned IP-address allocation schemes are already in place on the network. This is critical to prevent collisions and invalid or duplicate IP-addresses on the network. It is mandatory to enter a valid IP-address and a valid subnet mask. It is optional to enter a default gateway and DNS-server address. The default gateway is mandatory when the data goes outside the Local Area Network (LAN). The DNS-server is mandatory when an ARNI is used within the system. If the system has a DHCP-server active, in addition to using fixed IP-addresses, it is recommended to exclude the fixed IP-addresses from the DHCP-address range.

Additional information:

- Some devices have **multiple IP-addresses**. This refers to devices that contain multiple Network Interface Cards (NICs) or to the protocols they are using. Examples are the system controller and the call station, which contain a controller IP-address and an audio IP-address.
- **Managed switches** need a valid IP-address to change the configuration.

---

#### Notice!

When a DHCP-server is *added* to an existing PRAESENSA network in which the devices already have a Link-Local IP-address, then these devices will query a new IP-address from the DHCP-server and get a new address assigned. This results in temporary network disconnects.

When a DHCP-server is *removed* from an existing PRAESENSA network, initially all devices will continue to work with their assigned IP-addresses. However, when the lease time expires, they will revert back to a Link-Local IP-address. Since every device will do this at a different moment, this will lead to system instability for a prolonged time. It is better to switch off the power to the system, remove the DHCP-server and switch the system on again.







**Caution!**

When part of a PRAESENSA system is powered down, including the DHCP-server, while the rest of the system remains in operation, then, upon restart of the DHCP-server, some DHCP-servers may assign an IP-address to a restarting PRAESENSA device that is already in use by one of the devices in operation. This will result in unexpected behavior of the system and requires a power cycle of the whole system, to renew all IP-addresses. Also the DHCP-server function of the PRA-ES8P2S switch is suffering from this behavior; therefore this function is disabled by default and it is advised not to enable and use it.

**4.6.11**

**Transmission methods**

IP-communication takes place using the following transmission methods:

- **Unicast** is used for **one-to-one**, also known as **point-to-point**, transmission with one sender and one receiver. A switch detects which port a unicast IP-address is connected to and only forward packets to this port.

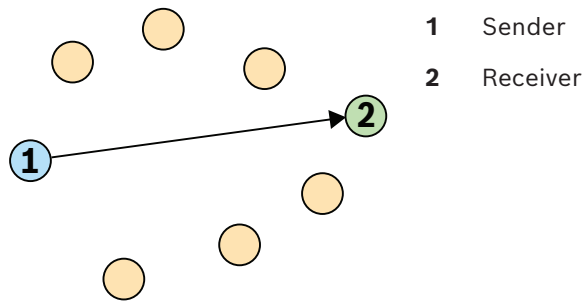

- **Broadcast** is used for **one-to-all** transmission with one sender and multiple receivers. With broadcast, the packets are sent to all devices in the subnet or VLAN. The data is then processed by the devices that need it, but ignored by others that do not. However, the bandwidth on the link is still utilized by sending this information.

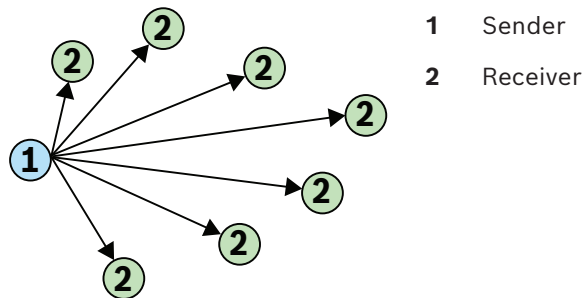

- **Multicast** is used for **one-to-many** transmission with just one sender and multiple receivers. Multicast differs from broadcast in that packets are sent only to the devices and ports that are interested in the data. This means that multicast traffic can make much more efficient use of available network bandwidth, but may also require the use of IGMP for management. Without IGMP, multicast traffic behaves as broadcast traffic.

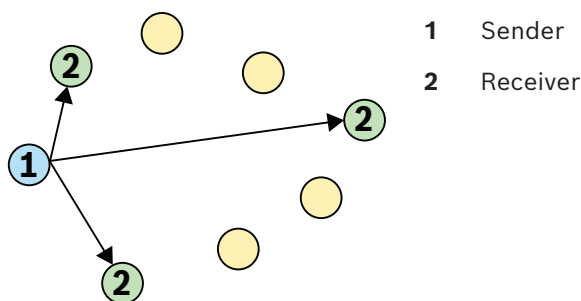

Although OMNEO supports unicast and multicast for audio streams, PRAESENSA uses multicast transmission for all dynamic OMNEO audio channels. An audio stream of a call station can be received by multiple amplifiers to play out in connected zones. Even during an announcement it is possible to add zones to that call by subscribing the appropriate amplifiers to the already existing multicast stream.

Exchange of control information is done one-to-one and uses a unicast transmission link. Dante audio streams can be configured as unicast or multicast stream, depending on the number of receivers (destinations).

## 4.7 Security precautions

PRAESENSA is an IP-connected, networked Public Address and Voice Alarm system. In order to ensure that the intended functions of the system are not compromised, special attention and measures are required during installation and operation to avoid tampering of the system. Many of such measures are provided in the PRAESENSA configuration manual and installation manual, related to the products and the activities described. This section provides an overview of precautions to be taken, related to network security and access to the system.

- Follow the installation instructions with respect to the location of equipment and the permitted access levels. Refer to *Location of racks and enclosures*, page 25. Make sure that call stations that address very large areas and operator panels that are configured for alarm functions only have restricted access using a special procedure, such as being mounted in an enclosure with lockable door or by configuration of user authentication on the device.
- It is highly recommended to operate PRAESENSA on its own dedicated network, not mixed with other equipment for other purposes. Other equipment may be accessible by unauthorized people, causing a security risk. This is especially true if the network is connected to the Internet.
- It is highly recommended that unused ports of network switches are locked or disabled to avoid the possibility that equipment is connected that may compromise the system. This is also the case for PRAESENSA call stations that are connected via a single network cable. Make sure that the connector cover of the device is in place and properly fixed, to avoid that the second network socket is accessible. Other PRAESENSA equipment should be installed in an area that is only accessible by authorized people to avoid tampering.
- Use an Intrusion Protection System (IPS) with port security where possible to monitor the network for malicious activity or policy violations.
- PRAESENSA uses secure OMNEO for its network connections. All control and audio data exchange use encryption and authentication, but the system controller allows the configuration of unsecure Dante or AES67 audio connections as an extension of the system, both as inputs and as outputs. These Dante/AES67 connections are not authenticated and not encrypted. They form a security risk, as no precautions are taken

- against malicious or accidental attacks through their network interfaces. For highest security, these Dante/AES67 devices should not be used as part of the PRAESENSA system. If such inputs or outputs are needed, use unicast connections.
- For security reasons, by default the PRA-ES8P2S Ethernet switch is not accessible from the Internet. When the default (special link-local) IP-address is changed to an address outside the link-local range (169.254.x.x/16), then also the default (published) password must be changed. But even for applications on a closed local network, for highest security the password may still be changed. Refer to *Installation, page 254*.
  - To enable SNMP, for example to use the Bosch Network analysis tool OMN-DOCENT, use SNMPv3. SNMPv3 provides much better security with authentication and privacy. Select the authentication level SHA and encryption via AES. To configure the switch accordingly, refer to *Installation, page 254*.
  - From PRAESENSA software version 1.50 onwards, the PRA-ES8P2S switches and the CISCO IE-5000 series switches report their power fault and network connection status directly to the PRAESENSA system controller through SNMP. The switches can be daisy-chained without an OMNEO device between them for connection supervision. The PRA-ES8P2S is preconfigured for this purpose from custom firmware version 1.01.05 onwards.
  - The system controller webserver uses secure HTTPS with SSL. The web server in the system controller uses a self-signed security certificate. When you access the server via https, you will see a Secure Connection Failed error or warning dialog indicating that the certificate was signed by an unknown authority. This is expected and to avoid this message in the future you have to create an exception in the browser.
  - Make sure that new user accounts for system configuration access use sufficiently long and complex passwords. The user name must have between 5 and 64 characters. The password must have between 4 and 64 characters.
  - The PRAESENSA system controller provides an Open Interface for external control. Access via this interface requires the same user accounts as for system configuration access. In addition, the system controller generates a certificate to setup the TLS (secure) connection between the system controller and the Open Interface client. Download the certificate and open/install/save the crt-file. Activate the certificate on the client PC. Refer to System security in the PRAESENSA configuration manual.
  - System access to the devices of this system is secured via the OMNEO security user name and passphrase of the system. The system uses a self-generated user name and long passphrase. This can be changed in the configuration. The user name must have between 5 and 32 characters and the passphrase must have 8 to 64 characters. To update the firmware of the devices, the firmware upload tool requires this security user name and passphrase to get access.
  - In case a PC for event logs is used (PRAESENSA logging server and viewer), make sure that the PC is not accessible by unauthorized persons.
  - Use secure VoIP protocols (SIPS) whenever possible, including verification through VoIP server certificate. Only use non-secure protocols when the SIP server (PBX) does not support secure VoIP. Only use VoIP audio in the protected sections of the network, because the VoIP audio is not encrypted.
  - Anyone with the ability to dial one of the extensions of the system controller can make an announcement in the PRAESENSA system. Do not allow external numbers to dial the system controller extensions.

Find all documentation and software related at [www.boschsecurity.com](http://www.boschsecurity.com) in the **Downloads** section of the PRAESENSA products.

Whenever you think you have identified a vulnerability or any other security issue related to a Bosch product or service, contact the Bosch Product Security Incident Response Team (PSIRT): <https://psirt.bosch.com>.

## 4.8 System topologies

PRAESENSA offers the possibility to set up small and large systems on different types of networks.



### Notice!

Each PRAESENSA system and subsystem can use a PRA-SCL or a PRA-SCS as system controller, as long as the limitations of the PRA-SCS are observed. Subsystem licenses apply to both in the same way. All systems can have an optional standby controller for more redundancy, but the duty and the standby system controllers must be of the same type.

### 4.8.1 System in a single subnet

In most projects, a PRAESENSA system uses a single active system controller, and all system devices are located in the same subnet of a network. Refer to *Network requirements and considerations*, page 34 for details on this system topology. The system controller can have a standby controller for fail-safe redundancy.

### 4.8.2 System with multiple subsystems in a single subnet

Create a large system by combining multiple subsystems on the same network, each with a system controller and other system components, like amplifiers and call stations. Each subsystem is self-contained and operates independently of the other subsystems. However, the subsystems can also operate as a single large system, under the control of an assigned master system. As such, the system size is no longer constrained to the system size limits mentioned in *System size limits*, page 36.

In this system topology:

- A maximum of 20 subsystems can be combined, each with up to 150 devices and 500 zones. This function is introduced with version V1.50 of the PRAESENSA software.
- The master system can have an optional standby controller for extra redundancy.
- Each subsystem can have an optional standby controller for extra redundancy.
- You can make calls from the master system to the subsystems and within a subsystem. No calls can be made between subsystems.
- In emergency mode, you can make calls throughout the entire system. The emergency and fault status are carried over from the subsystems to the master system and from the master system to the subsystems.
- The lifeline between a PRA-AD604 or PRA-AD608 amplifier and a PRA-MPS3 only works if both devices are part of the same subsystem.
- This system topology, including the Ethernet switches, is certified for EN 54-16. This system topology does not comply to the DNV-GL Type Approval.



### Notice!

You need to activate a subsystem license in a system controller to turn it in a master controller. The master controller requires one active license for each subsystem. A standby master controller needs the same amount of licenses as the duty master controller. The controller of a subsystem license includes the right to use a redundant standby controller.

### 4.8.3 System with devices in different subnets

A PRAESENSA system can have some of its devices in a different subnet. For instance, a call station can be located in a different building. PRAESENSA uses OMNEO as a network protocol. When an OMNEO network uses multiple subnets, it requires the use of network synchronizers in each subnet: one OMN-ARNIE Network synchronizer enterprise for the main subnet and one OMN-ARNIS Network synchronizer single for each additional subnet. The OMN-ARNIE and OMN-ARNIS are small industrial Linux computers that function as a high performance Dynamic Host Configuration Protocol (DHCP) server and as a Domain Name System - Service Directory (DNS-SD) server. They are used to discover all OMNEO equipment in a routed network without the need for and load of Multicast DNS. OMN-ARNIE also extends the use of Precision Time Protocol (PTP) over multiple IP-subnets by acting as a grandmaster PTP clock for all subnets with OMNEO devices and as a multicast master for its own subnet. OMN-ARNIS acts as a boundary clock, synchronized to an OMN-ARNIE.

In this system topology:

- The use of multiple subnets requires an OMN-ARNIE in the main subnet and an OMN-ARNIS in each other subnet used.
- Each ARNI can use a standby ARNI of the same type (OMN-ARNIE or OMN-ARNIS) for dual redundancy.
- Each ARNI must be powered from a 48 VDC output of the PRA-MPS3. As such, each ARNI is powered from the mains and, when needed, from a backup battery. Because the ARNI only has a 12 VDC power supply input, the 48 VDC from the PRA-MPS3 must be converted to 12 VDC first. For this purpose the Meanwell DC/DC converter DDR-60L-12 has been certified in combination with PRAESENSA.
- This multi-subnet topology requires a Layer 3 (L3) switch or router. For this purpose, the industrial Ethernet switch CISCO IE-5000-12S12P-10G is certified with PRAESENSA.
- The PRAESENSA multi-subnet solution is certified for EN 54-16 in combination with the products that are listed in the next table.

Material description	Manufacturer	Commercial code	HW version	SW version	Bosch order code
Network synchronizer enterprise	Advantech	ARK1123 C-CTOS-ENNLBO02-M4	2.1 - 3.1	8.41	OMN-ARNIE
Network synchronizer single	Advantech	ARK1123 C-CTOS-ENNLBO02-M5	2.5 - 2.8	8.41	OMN-ARNIS
DC-to-DC converter	Mean Well	DDR-60L-12			
Industrial ethernet switch	CISCO	IE-5000-12S12P-10G	V06	15.2	

Low Voltage DC Power Source for IE-5000	CISCO	PWR-RGD-LOW-DC-H	V01		
10G SFP Transceiver Module	CISCO	SFP-10G-LR	V02		
1G SFP Transceiver Module	CISCO	GLC-LX-SM-RGD	V02		

For connections between SFP ports inside a rack, the CISCO SFP-H10GB-CUxM copper Twinax cables can be used, with the 'x' being the length in meters. As long as they stay in the rack, this is not field wiring and supervision is not needed for UL 2572. As long as these cables stay in the rack, EN 54-16 does not require redundant wiring.

#### 4.8.4

#### System with multiple subsystems in different subnets

A large system with multiple subsystems as described in *System with multiple subsystems in a single subnet, page 45* can also be created when the subsystems are located in different subnets of the network. Similar as the case described in *System with devices in different subnets, page 46*, this topology requires one OMN-ARNIE Network synchronizer enterprise for the main subnet and one OMN-ARNIS Network synchronizer single for each additional subnet. The characteristics and requirements are also similar as for the previous system with some devices in a different subnet.

### 4.9

#### Port numbers

- In IP networks, port numbers are part of the address allocation information.
- Port numbers are used to identify the senders and receivers of the messages.
- Port numbers are associated with TCP/IP network connections.
- Port numbers might be described as an add-on to the IP address.
- Port numbers allow different applications on the same computer to share network resources simultaneously.

Networking ports are software-based and unrelated to the physical ports that the network devices have for plugging in cables.

Port numbers relate to network address allocation. In TCP/IP networking, both the TCP and the UDP use a set of ports that work together with IP addresses. A computer can have a main address and a set of port numbers to handle the incoming and the outgoing connections. One IP address can be used to communicate with various applications behind one router. The IP address identifies the destination computer. The port number identifies the specific destination application, such as the mail application, the file transfer program, or the web-browser. To access a website from a web browser, the browser communicates over port 80 for HTTP.

In both the TCP and the UDP, port numbers start at 0 and go up to 65535. Numbers in the lower ranges are dedicated to common internet protocols, such as port 25 for SMTP and port 21 for FTP.

### Open and closed ports

Port numbers can be a key aspect of attack vulnerabilities and protections. Ports can be classified as either open or closed. Open ports have an associated application that listens for new connection requests. Closed ports do not.

A process called network port scanning detects test messages at each port number. This process identifies which ports are open. Network professionals use port scanning as a tool to measure the exposure to attackers. Often, they lock down networks by closing non-essential ports. Hackers, in turn, use port scanners to probe networks for open ports that may be exploitable.

The **netstat** command in Windows can be used to see information regarding active TCP and UDP connections.

### Ports used by PRAESENSA

PRAESENSA uses OMNEO for the transport of audio and control data. The TCP and the UDP protocols are used to communicate. It is important to consider that the following ports are being used in the PRAESENSA system. As such, these ports should not be blocked. The ports are separated in groups:

- The system ports 0 - 1023 use a standardized protocol. These ports are formally assigned by the Internet Assigned Numbers Authority (IANA).
- The user ports 1024 - 49151 are assigned by IANA on request.
- The dynamic and private ports 49152 - 65535 are free to use.

System ports 0 - 1023				
Protocol name	Usage	TCP/UDP	Ports	Transfer
SSH	Secure SHell access (ARNI)	TCP	22	
Telnet	Access to the command prompt (disabled, temporarily enabled by some applications)	TCP	23	
DNS	Domain Name Server	TCP/UDP	53	
DNS-SD	DNS-based Service Discovery	TCP/UDP	53	Unicast
DHCP	Dynamic Host Configuration Protocol (for IP address assignment)	UDP	67	Broadcast (except when using IPv4LL)
TFTP	Trivial File Transfer Protocol (for firmware update)	UDP	69	Unicast
HTTP	Hypertext Transfer Protocol (for configuration)	TCP	80	Unicast
NTP	Network Time Protocol daemon	UDP	123	
PTPv1	Dante clock synchronization	UDP	319 - 320	
PTPv2	AES67 clock synchronization	UDP	319 - 320	Multicast/ Unicast
HTTPS	Secure configuration web interface	TCP	443	Unicast



<b>User ports 1024 - 49151</b>				
<b>Protocol name</b>	<b>Usage</b>	<b>TCP/UDP</b>	<b>Ports</b>	<b>Transfer</b>
TFTP	Trivial File Transfer Protocol (for firmware update)	UDP	1024	Unicast
Dante Audio	Multicast Dante audio	UDP	4321	Multicast
AES67	AES67 audio	UDP	5004	Multicast
DNS-SD	DNS-based Service Discovery	TCP/UDP	5030	
mDNS NAT-PMP	Multicast DNS NAT-PMP socket	UDP	5350	
DNS-SD-LLQ	DNS-SD long-lived queries	TCP/UDP	5352	
mDNS/DNS-SD	Multicast DNS and DNS-based service discovery	UDP	5353	Multicast
Private DNS	Private DNS port	TCP	5533	
DHCP	DHCP server (for fail-safe recovery)	UDP	6700	
arnid	ARNI daemon	UDP	8600	
Conmon	Audinate control and monitoring	UDP	8700 - 8708	
Conmon	Audinate control and monitoring	UDP	8800	
Open Interface	PRAESENSA API	TCP	9401	Unicast
Open Interface	Secure PRAESENSA API (TLS)	TCP	9403	Unicast
OCP	Object Control Protocol	TCP	9470	
Secure OCP	Secure Object Control Protocol	TCP	9471	
DNS-SD Helper	DNS-based Service Discovery Helper	TCP	9474	Unicast

ARNI reconfirm	ARNI confirm presence request	UDP	9474	
DNS reconfirm relay	DNS-SD reconfirm relay port	UDP	9475	
SAP	AES67 multicast streams discovery	UDP	9875	Multicast
Dante Audio	Unicast Dante audio	UDP	14336 - 14591	Unicast
Logging server	PRAESENSA logging server	TCP	19451	Unicast

<b>Dynamic and private ports 49152 - 65535</b>				
<b>Protocol name</b>	<b>Usage</b>	<b>TCP/UDP</b>	<b>Ports</b>	<b>Transfer</b>
OCA OCP.1	Open Control Architecture OCP.1 (control protocol)	TCP/UDP	49152 - 65535	Unicast
OCA OCP.1 Secure	Open Control Architecture OCP.1 (secure control protocol)	TCP/UDP	49152 - 65535	Unicast
arnid	ARNI daemon	UDP	49152 - 65535	
Audio keep alive	Keep alive communication (for unicast Dante audio)	UDP	61440 - 61951	Unicast

## 5 System composition

For large sound systems it may not be immediately clear how many amplifiers are needed, and which model, to connect the loudspeaker loads in all zones. Also, how many power supplies are needed for these amplifiers, the system controller, call stations and other system components, and what the backup battery size should be for the multifunction power supplies.

### 5.1 Constant voltage systems

Public address audio installations often require large numbers of loudspeakers to be powered from a single amplifier. Using traditional low impedance loudspeakers (4-16 ohm), like used in consumer audio installations, would make it very difficult to connect all these loudspeakers, especially when not all loudspeakers have the same power rating. Simple parallel connection of all loudspeakers would create a very low impedance load that the amplifier most likely cannot drive. Connecting the loudspeakers in a series-parallel fashion (e.g. 4 parallel strings, each with 4 loudspeakers in series) keeps the overall load impedance the same as for an individual loudspeaker, but all loudspeakers will get the same amount of power, even when small and large loudspeakers are mixed, for instance because some loudspeakers need to be louder than others. Also wiring the loudspeakers would be difficult and error prone.

#### Solution

There is a very simple and elegant solution to this problem: constant voltage systems. A constant voltage system is a system that uses a standardized maximum signal level for amplifiers and loudspeakers. Most frequently used are 70 V systems (in USA) and 100 V systems (rest of the world).

- A 100 V amplifier is capable of delivering 100 VRMS sine wave power (equal to 282 V<sub>peak-to-peak</sub>) before clipping.
- A 100 V loudspeaker is designed to deliver its specified maximum output level with a 100 V input signal.
- A 30 W loudspeaker takes 30 W at 100 V and a 6 W loudspeaker takes 6 W at 100 V.

Now all loudspeakers belonging to the same group can simply be connected in parallel with perfect power distribution and no risk of overloading some loudspeakers. The total loudspeaker load of such a set of parallel connected loudspeakers is just the sum of all individual loads. Of course, the amplifier must be capable to deliver at least that amount of power.

Loudspeakers for constant voltage usage have a much higher impedance than the typical 8 ohm of a consumer loudspeaker, because an 8 ohm loudspeaker would dissipate 1250 W when driven by a 100 V signal. A 10 W loudspeaker for 100 V usage has an impedance of 1 kohm. The loudspeaker voice coil cannot be made with such long and thin wire to achieve that high impedance. Instead, a normal loudspeaker is used with an impedance of around 8 ohm, combined with an input transformer to convert the 100 V input to e.g. 9 V output, just enough for 10 W into 8 ohm. Using a 100 V distribution line to drive the loudspeakers requires much lower currents to transfer the same amount of power. That means that thinner wires can be used to connect the loudspeakers and also the cable losses are much lower. This is very important when long loudspeaker lines are to be used, such as often required for public address systems, covering large areas. Loudspeakers for the same zone are then connected in a daisy chain, to make it possible to supervise the whole line with a single end-of-line device. Star wiring of loudspeakers should be avoided, as it often uses much more loudspeaker cable and cannot be supervised easily.

Traditionally the power amplifiers also use transformers to convert the relatively low maximum output voltage of the amplifier to the standardized 100 V distribution level. The size and weight of these transformers scale with their power handling capabilities and determine to a large extent the size and weight of the whole amplifier. PRAESENSA amplifiers, however, use high power supply voltages to create a 100 V (or 70 V) output signal without the use of output transformers. This does not only save weight but also improves the audio quality, as transformers operate within a limited frequency range and may suffer from core saturation at very low frequencies. Another big benefit is that the output power of an amplifier channel is not limited anymore by the size of its output transformer, an important pre-condition for flexible power allocation across output channels for multi-channel amplifiers.

## 5.2 Amplifier selection

The flexibility of the PRAESENSA multi-channel power amplifiers makes it possible to cover most demands with just a few different models, the PRA-AD604 and PRA-AD608. Both models have a power budget of 600 W in total, to power the loads for 4 or 8 channels. Because the channels can be loaded with any amount of loudspeaker load within the 600 W budget of the whole amplifier, only the average channel load determines which amplifier fits best to the load. The PRA-AD608 is capable to drive 600 W of load into 8 zones, so it fits best when the average zone size is  $600/8 = 75$  W, or less. The PRA-AD604 fits best when the average zone size is  $600/4 = 150$  W, or more. When the average zone size of a large system is between 75 W and 150 W, then a mix of PRA-AD604 and PRA-AD608 amplifiers is needed.

To determine quickly the minimum amount and type of amplifiers that are needed for a project, use the following rules:

1. Check how many locations are needed for equipment clusters to be installed (technical rooms). System decentralization into clusters is often needed because of the size of the area that needs to be covered by the system. Decentralization of equipment is a good way to minimize the amount of loudspeaker cabling by positioning the amplifiers closer to the connected loudspeakers in each zone. Often clusters are located per fire zone, each covering multiple separately addressable smaller zones, to mitigate the requirement of fire resistant loudspeaker cabling.
  - The next steps for calculation must be executed for each cluster separately.
2. Count the number of zones for this cluster. Zones with a loudspeaker load > 600 W need to be split into sub-zones with a maximum load < 600 W each, because they require more than one amplifier. Then count the subzones instead of the original large zone.
  - Example: Cluster A serves 52 (sub-)zones, each needing its own amplifier channel.
3. Add up the loudspeaker loads of all zones to get the total loudspeaker load. For loudspeakers that are tapped down to get the required sound pressure level (and not more), use the tapped down power setting in the summation. Often a project asks for a margin on the power for later expansion, then count that margin in.
  - Example: The total loudspeaker load for cluster A is 4300 W and 20% margin is needed. Then the total load for calculation is  $4300 \times 1.2 = 5160$  W.
4. Based on the number of zones at least a certain number of amplifiers is needed to have enough channels to drive each zone separately. Because the PRA-AD608 has the most channels (8), divide the number of zones by 8 and round up.
  - Example: Cluster A has 52 zones, so at least  $52/8 = 6.5$  amplifiers are needed, that means at least 7 whole amplifiers.

5. Based on the loudspeaker load, including margin, at least a certain number of amplifiers is needed to have enough power available to drive the total load. Because all amplifiers are 600 W capable, divide the total load by 600 W and round up.
  - Example: Cluster A needs 5160 W, so at least  $5160/600 = 8.6$  amplifiers are needed, that means at least 9 whole amplifiers.
6. Some large loudspeaker zones may need more than 300 W each. These zones cannot be connected to the same amplifier because then the total power would become  $> 600$  W. These zones need at least their own amplifier, although smaller zones may be added to other channels of that amplifier. Count the number of such large zones.
  - Example: Of the 52 zones in cluster A there are 5 with a load of around 400 W, so at least 5 amplifiers are needed already for these zones.
7. The required number of amplifiers is now the biggest number that came out of steps 4, 5 and 6. That number represents the deciding factor for this cluster.
  - Example: Based on channel count 7 amplifiers are needed, based on total loudspeaker load 9 amplifiers are needed and based on large zones at least 5 amplifiers are needed. That means that 9 amplifiers are needed because loudspeaker load is the deciding factor here.
8. To know what type of amplifiers is needed, it is important to consider the average number of channels per amplifier that is needed for this cluster. When it is  $< 4$ , then the cluster can use 4-channel amplifiers all over. When it is  $> 8$ , then all amplifiers must be 8-channel. When it is between 4 and 8 channels per amplifier, a mix of both models is needed, based on interpolation.
  - Example: Cluster A needs 52 channels for 52 zones and uses at least 9 amplifiers. This is  $52/9 = 5.78$  channels per amplifier, which is between 4 and 8. Then the number of 8-channel amplifiers can be calculated via interpolation:  $9 \times (5.78 - 4) / 4 = 4$ , meaning that cluster A needs 4 pieces of PRA-AD608, so the other  $9 - 4 = 5$  amplifiers can be PRA-AD604.
9. Now the minimum number of amplifiers is known and, if no other requirements exist, this number is sufficient as a basis for further system design, even without knowing what the actual load of each zone is. Because of other requirements more amplifiers may be needed, e.g. when certain groups of zones must be connected to the same amplifier; then it may not be possible to optimize the load assignment across all amplifiers.

Also when the cluster has many relatively big zones and very few small zones, it may happen that another amplifier is needed because the remaining power budget of each of the amplifiers is not enough to accept the load of another big zone, although the sum of all the remaining budgets of all amplifiers is more than enough for that big zone. It may help to split up such a zone in smaller sub-zones.

## 5.3 Amplifier power and crest factor

The PRA-AD604 and PRA-AD608 amplifiers are designed for a maximum loudspeaker load of 600 W. Of course the amount of power that is actually delivered to the loudspeakers depends on the audio signal being amplified. A full scale sinewave signal with an RMS (Root Mean Square) voltage of 100 V into a resistive loudspeaker load of 16.7 ohm would cause 600 W of power to be delivered to that load. For this RMS output voltage of 100 V, the peak output voltage is 141 V. For a sine wave, the RMS voltage is 3 dB lower than its peak voltage. This can also be expressed as that a sine wave has a crest factor of 3 dB, because by definition the crest factor of a signal is the ratio of its peak level to its RMS level. A square wave signal has a crest factor of 0 dB because its peak level and its RMS level is the same. Pink noise has a crest factor of 12 dB and a typical STIPA test signal has a crest factor of 13 dB. The crest factor of voice signals is approximately 12 dB. That is, the peaks of speech are about 12 dB more intense than the average values. This is caused by natural damping of the human vocal tract due to the nasal cavity, soft cheeks, soft tongue, lips, et cetera. Musical instruments, however, are not so well damped. Hard walled horns and stiff resonator chambers all yield a physical musical signal with much higher crest factors. Typical crest factors for musical instruments are on the order of 18 to 20 dB. That is, with musical instruments, peaks tend to be sharper than for speech. On the other hand, for recorded music the crest factor is often lowered by mixing of multiple instruments and additional sound processing in order to get a more even output level, where soft signals don't disappear in the ambient noise and loud fragments are not disturbingly loud.

It is sufficient that an amplifier can drive its loudspeaker load to the maximum level only during peaks; its long term (average) power capability can be much lower. It is generally accepted that a continuous output power of 1/8 of the maximum sinewave power is sufficient for most types of music and speech. The PRA-AD604 and PRA-AD608 amplifiers have more margin and can deliver a continuous RMS output power of 1/4 of the maximum sine wave power, which is 150 W for a 600 W amplifier. For short periods of time (bursts) the maximum output power is 600 W. This additional margin is used to play continuous alarm tones at a relatively high level. An even higher level would not be very useful because PRAESENSA is a Voice Alarm system, and the loudness of an alarm tone should not be significantly higher than the loudness of the voice signal, otherwise the voice signal would be perceived as softer and not very clear.

PRAESENSA uses digital signal processing and transport. The maximum peak voltage of 141 V at an amplifier channel output corresponds to a digital signal level of 0 dBFS (dB Full Scale). The RMS level of a full scale sinewave is 3 dB lower, so -3 dBFS, corresponding to an RMS voltage of 100 V. In the 70 V mode all voltage levels are 3 dB lower for the same digital signal level in dBFS. In order to keep the RMS power at 150 W for a 600 W loudspeaker load, the RMS signal level must be 6 dB lower. This means that the RMS level of the digital signal should not be more than -9 dBFS. Peaks can be as high as 0 dBFS. The PRAESENSA amplifiers have an integrated RMS power limiter that reduces the signal level to all channels when the combined output power of all channels together exceeds 150 W for a too long time.

PRAESENSA has a library of attention tones, alarm tones and test tones, formatted as wav-files. These tones all have an RMS level at or below -9 dBFS. For custom made tones this should not be different. For instance, one of the multi-sine alarm tones in the audio editing program Audacity may look like this:

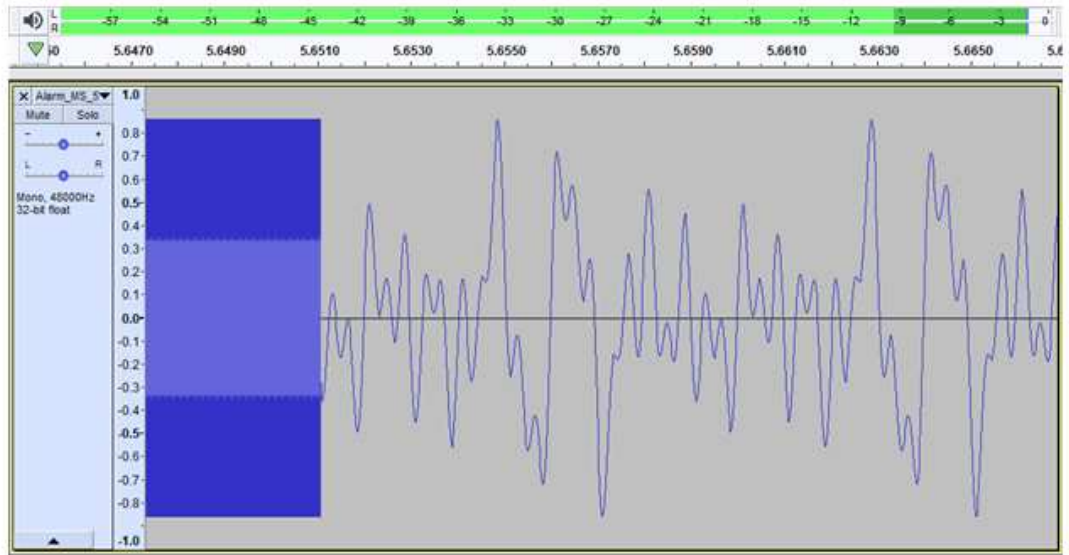

The peaks are at -1.3 dBFS (= 0.86 of full scale) and the RMS level is at -9.4 dBFS (= 0.34 of full scale). Both these levels are also visible in the level bar at the top.

## 5.4 Battery calculation

The PRAESENSA system includes multifunction power supplies, like the PRA-MPS3, to power other PRAESENSA devices from the mains, but also from a battery in case of mains failures. PRAESENSA encourages to use a distributed system approach, in order to minimize expensive (fire resistant) loudspeaker cabling, therefore each multifunction power supply uses its own battery. There is no large battery set that supplies power to a centralized system on one location.

### 5.4.1 Topology

Each PRA-MPS3 multifunction power supply has the capability to power up to three amplifiers via 48 VDC, one system controller (or other device) via 24 VDC and one Call station via PoE. A single 12 V battery is charged by the multifunction power supply to which it is connected. This battery serves as a backup power source during mains failures. A large system with dozens of amplifiers will contain many PRA-MPS3 devices, each having its own battery. This means that the required capacity of each battery must be calculated separately for the PRA-MPS3 it is connected to, taking the load into account that is served by this specific PRA-MPS3.

For the devices that are powered from a PRA-MPS3, it is important to notice that the power consumption of each device may vary depending on operation modes and how it is connected. When the power consumption has been calculated or measured, the corresponding battery current draw (in case of a mains failure) can be calculated or measured. The power taken from the battery will always be slightly higher than the power that is consumed by the device, because of additional losses in the DC/DC converters inside the PRA-MPS3 that convert the battery voltage to 48 VDC and 24 VDC.

## 5.4.2

### Operating conditions

#### PRA-SCL | PRA-SCS

The power consumption of the PRA-SCL / PRA-SCS is relatively small, stable and hardly affected by system activities. It is powered from the 24 VDC output of the PRA-MPS3. Only the number of active Ethernet ports increases the power consumption. At least one port will be in use, but often more ports are active. In case of a connection to a PC for logging and to two independent loops for linking to other PRAESENSA devices, all five ports will be in use.

#### PRA-CSLD | PRA-CSLW | PRA-CSE | PRA-CSBK | PRA-CSEK

The power consumption of the PRA-CSLD and PRA-CSLW is the same. Again, the power consumption consists of a fixed part with an increment per active Ethernet port. Power is supplied via PoE to one or both ports. Power is taken from the port that has the highest PoE voltage. This means that if a call station is powered from two different PoE sources, like two different PRA-MPS3 power supplies for additional redundancy, because of tolerances all of the power may be taken from one of the power supplies. Only upon disconnection of that Ethernet cable, the call station will take power from the other power supply. Even if both PoE voltages are the same, using one short cable and one long cable may result in that most of the power is taken via the shortest cable because then the voltage drop across the wire resistance of each cable is equal.

Connecting PRA-CSE(K) extensions to the call station will increase its power consumption slightly, the increment depends on the number of LEDs that are on, but on average that contribution is very limited because selections are only active during calls.

When a call station is configured for emergency purposes it may happen that a fault or failure occurs and the buzzer of the call station is activated as an audible fault alarm. This is only the case for emergency call stations, but the power consumption of the buzzer must then be taken into account because the fault may not be acknowledged and then the buzzer continues.

#### PRA-AD604 | PRA-AD608

The PRA-AD604 and PRA-AD608 amplifiers are designed for low power consumption, especially when powered from a battery, by incorporating different modes of operation. When the amplifier is running on mains power and there is no audio signal present, it is operating in idle mode on a reduced power supply voltage to keep the idle power consumption relatively low. When an audio signal is present for one or more of the audio channels, then the power supply voltage increases to the normal operating voltage to be able to drive loudspeaker lines up to 100 VRMS. This increases the idle losses in the amplifier channels. Of course, when the amplifier provides full output power to the loudspeakers, the power consumption increases significantly. Full output power means a continuous output power of 150 W into a 600 W loudspeaker load. Because typical speech and music signals have a crest factor of more than 9 dB, the RMS power remains below 150 W while the burst output power is 600 W.

When the mains voltage on the PRA-MPS3 fails, it switches to the battery to take power from. The PRA-MPS3 notifies the amplifier of this and when the amplifier doesn't have to make announcements of high enough priority, it will go into sleep mode or snooze mode and notifies the PRA-MPS3 to switch off the 48 VDC power section to this amplifier. The amplifier then operates directly from the battery via the lifeline interconnection. In sleep mode the power consumption is lowest but there is no amplifier and loudspeaker line supervision active. When supervision has been enabled for this amplifier, the amplifier will go into snooze mode, which is a combination of being in sleep mode for most of the time, but waking up into idle mode to perform a supervision cycle for a few seconds every 90 seconds. The average power consumption in snooze mode is somewhat larger than in sleep



mode. When a call is being made or a tone played to one or more of the channels, the amplifier immediately requests the PRA-MPS3 to switch on the 48 VDC power supply again and the amplifier will operate from the normal supply voltage. The power consumption of the active amplifier will then vary between the value for low power (small signal audio or small loudspeaker load) and full power (audio in full load at maximum level).

In all modes, the power consumption of the active Ethernet ports must be taken into account.

Because the PRA-AD608 has nine amplifier channels, while the PRA-AD604 has five channels, the power consumption of the PRA-AD608 is slightly higher than of the PRA-AD604.

### **PRA-ES8P2S**

This Ethernet switch has dual redundant 24 to 48 V DC-inputs. In case no battery backup is required, it can be powered from a PRA-PSM24 or PRA-PSM48 power supply. In case the switch is used in a Voice Alarm system, compliant to EN 54-16, the switch must be powered from an EN 54-4 certified power supply, like the PRA-MPS3.

When the switch is powered by the PRA-MPS3 multifunction power supply, it must be connected to one of the 48 V outputs, normally intended for the amplifiers. Use both A and B outputs for connection redundancy. The 24 V output of the PRA-MPS3 is not powerful enough for this switch. The 48 V output that is powering the switch should not be used to also power an amplifier. Especially when the switch is serving multiple PoE powered devices as PSE (Power Sourcing Equipment), its power consumption can raise to 140 W. The remaining power capacity of the 48 V supply is not sufficient anymore for an amplifier under various load conditions.

The lifeline that belongs to the powering 48 V output is not used, so the 48 V output will not be disabled as would be for amplifiers in sleep/snooze mode to save power. It is also essential that the 48 V for the switch is not disabled at any time. In case of mains failure the switch will be powered from the battery, connected to the multifunction power supply. The power consumption of the switch is highly dependent on the number of ports that are in use and whether these ports provide PoE power to connected devices. Next to the power consumption of the switch itself and the power consumption of the active ports, the PoE loads of all ports together (expressed in watt) multiplied by 0.1 gives the approximate additional load of the battery (expressed in ampere). Please note that a call station that is connected to this switch and powered via PoE from this switch will load the battery slightly more than when the same call station would have been directly powered from a PoE port of the PRA-MPS3, because the switch in between has some 20% additional losses.

### **PRA-MPS3**

The power consumption of the PRA-MPS3 itself is mainly determined by its network interface and the number of active Ethernet ports (RJ45 or SFP). For the battery capacity calculation, the power loss of the DC/DC converters to supply power to all connected devices is already taken into account in the power taken from the battery by these devices. The power consumption of the relays of the control outputs is insignificant.

### **PRA-ANS**

The power consumption of the PRA-ANS device is relatively low but not to be neglected, especially if multiple devices are used. The power is supplied through a single PoE connection. It is not strictly needed for a PRA-ANS to be connected to a power source with a battery backup. If the PoE and the link disappear, the AVC deactivates for the affected zone. In this condition, calls will be at the highest level within the AVC control range.

**PRA-IM16C8**

The power consumption of the PRA-IM16C8 varies with the number of connected Ethernet ports, and the number of activated LEDs and output relays. It can vary between 2.6 W and 4.5 W. A typical value for battery calculation is 4.2 W when both Ethernet ports are used. Power is supplied through PoE to one or both ports. The highest PoE voltage port supplies the power. If the module is powered from two different PoE sources, like two different PRA-MPS3 power supplies for additional redundancy, one of the power supplies may supply all the power because of tolerances. Only if you disconnect that Ethernet cable, the module receives power from the other power supply. Even if both PoE voltages are the same, using one short cable and one long cable can result in that most of the power is supplied through the short cable.

**PRA-WCP**

The power consumption of the PRA-WCP device is relatively low but not to be neglected, especially if multiple devices are used. The power is supplied through a single PoE connection. The wall control panel does not affect alarm calls. Because of that, a PRA-WCP does not strictly need to be connected to a power source with a battery backup.

### 5.4.3 Power consumption

The following table gives an overview of the power demand of the PRAESENSA devices for the different operating conditions.

Device	Device elements	Power consumption [W]	Power from battery [W]	Current from battery [A]
PRA-SCL / PRA-SCS	System controller	3.9	4.2	0.35
	+ per active RJ45 port	0.4	0.5	0.04
PRA-CSLD / PRA-CSLW	Call station	4.2	5.0	0.42
	+ per active RJ45 port	0.5	0.6	0.05
	+ per extension PRA-CSE	0.1	0.1	0.01
	+ with alarm option	1.2	1.5	0.12
PRA-AD604	Amplifier (sleep)	6.0	6.0	0.50
	Amplifier (snooze)	7.5	8.0	0.67
	Amplifier (active, idle)	36	43	3.58
	Amplifier (active, low power)	50	60	5.00
	Amplifier (active, full power)	222	244	20.33
	+ per active RJ45 port	0.4	0.4	0.03
PRA-AD608	Amplifier (sleep)	6.0	6.0	0.50
	Amplifier (snooze)	8.9	9.5	0.79
	Amplifier (active, idle)	56	68	5.67
	Amplifier (active, low power)	77	93	7.75
	Amplifier (active, full power)	246	271	22.58
	+ per active RJ45 port	0.4	0.4	0.03
PRA-ES8P2S	Ethernet switch	7.0	8.4	0.70
	+ per active RJ45 port	0.4	0.5	0.04
	+ per active SFP port	0.7	0.8	0.07
	+ PoE load	load	1.2 x load	0.1 x load
PRA-MPS3	Multifunction power supply	5.2	5.2	0.43
	+ per active RJ45 port	0.4	0.4	0.03
	+ per active SFP port	0.7	0.7	0.06
PRA-ANS	Ambient noise sensor	1.6	1.9	0.16
PRA-IM16C8	Control interface module	3.2	3.8	0.32
	+ per active RJ45 port	0.5	0.6	0.05
PRA-WCP-EU / PRA-WCP-US	Wall control panel	1.3	1.6	0.13

Measure the battery current consumption of the system with a clamp meter for DC current. A clamp meter is an electrical tester that measures the amount of current flowing through a conductor. A clamp meter, contrary to a standard multimeter, measures the magnetic field that is created by the current flow with a Hall effect sensor. As a result, the clamp meter can attach onto a conductor and measure the current without disconnecting any wires. Make sure that the jaws of the clamp are around one of the wires connected to the battery.

Make sure that the meter is set to measure the DC current. Not all current clamp meters can measure DC current. Do not use a clamp meter with AC current. For accurate results, keep the cable in the center of the hole.

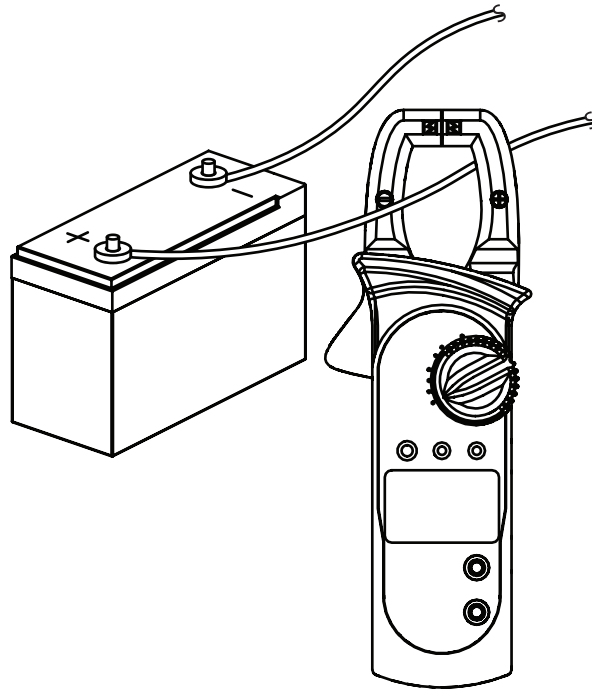

### 5.4.4 Accurate battery size calculation

The size or capacity of the battery for each cluster of devices, consisting of a PRA-MPS3, up to three amplifiers and optionally a system controller and a call station, can be calculated by using the current taken from the battery for each device element, as shown in the previous section.

Of importance is for how long the system must be able to operate on the battery. Most emergency sound systems are specified to run on battery for 24 hours in quiescent mode and then subsequently for 30 minutes doing (voice) alarms.

#### System example

Consider a voice alarm system that consists of the devices as shown in the next table.

Device	Device elements	Current taken from battery [A]	Time in quiescent mode [h]	Time in alarm mode [h]	Current x time [Ah]
PRA-SCL	System controller	0.35	24	0.5	8.58
	+ per active RJ45 port (2)	2 x 0.04	24	0.5	1.96
PRA-CSLD	Call station	0.42	24	0.5	10.29
	+ per active RJ45 port (2)	2 x 0.05	24	0.5	2.45
	+ per extension PRA-CSE (3)	3 x 0.01	24	0.5	0.73
	+ with alarm option	0.12	24	0.5	2.94
PRA-AD604	Amplifier (sleep)	0.50	-	-	-
	Amplifier (snooze)	0.67	24	-	16.08
	Amplifier (active, idle)	3.58	-	-	-
	Amplifier (active, low power)	5.00	-	-	-
	Amplifier (active, full power)	20.33	-	0.5	10.17
	+ per active RJ45 port (2)	2 x 0.03	24	0.5	1.47
PRA-AD608	Amplifier (sleep)	0.50	-	-	-
	Amplifier (snooze)	0.79	24	-	18.96
	Amplifier (active, idle)	5.67	-	-	-
	Amplifier (active, low power)	7.75	-	-	-
	Amplifier (active, full power)	22.58	-	0.5	11.29
	+ per active RJ45 port (2)	2 x 0.03	24	0.5	1.47
PRA-AD608	Amplifier (sleep)	0.50	-	-	-
	Amplifier (snooze)	0.79	24	-	18.96
	Amplifier (active, idle)	5.67	-	-	-
	Amplifier (active, low power)	7.75	-	-	-
	Amplifier (active, full power)	22.58	-	0.5	11.29
	+ per active RJ45 port (2)	2 x 0.03	24	0.5	1.47
PRA-MPS3	Multifunction power supply	0.43	24	0.5	10.53
	+ per active RJ45 port (2)	2 x 0.03	24	0.5	1.47
	+ per active SFP port	0.06	-	-	-
<b>Total calculated battery capacity [Ah]</b>					<b>130.11</b>
<b>Required battery capacity (30% oversized) [Ah]</b>					<b>170</b>

All devices are connected in a single loop, which means that all devices have two ports in active use for loop-through cabling. The PRA-CSLD is used as emergency call station and has three extensions connected. Because this is a voice alarm system, supervision is enabled. Furthermore the system is specified to run from a battery for 24 hours in quiescent mode and 30 minutes in alarm mode.

Manufacturers specify the capacity of a lead-acid battery at a specified discharge rate. Typically the specified (nominal) battery capacity is based on fully discharging the battery in 20 hours with a constant (nominal) current. If the battery is discharged at a faster rate, the delivered capacity is less, and if the battery is discharged at a slower rate the delivered capacity is more. This effect is described by Peukert's law. Without going into detail, this law describes an exponential relationship between the discharge current and the delivered capacity over a specified range of discharge currents. For flooded lead-acid batteries this effect is very significant, for VRLA batteries this effect is much smaller but certainly not negligible.

Consider a PRAESENSA system with a battery capacity that is sufficient for 24 h operation in quiescent mode, followed by 0.5 h operation in alarm mode. In quiescent mode the discharge current will be around half of the nominal current and a typical VRLA battery then has an effective capacity of 110% of the nominal capacity. But during alarm mode the discharge current can be up to ten times higher than the nominal discharge current and the effective battery capacity then reduces to 75% of the nominal capacity. The consequence of this is that the required nominal battery capacity should be around 20% higher than calculated without taking Peukert's law into account.

Because another 10% additional battery capacity is needed to compensate for aging and low temperature operation, the battery must be oversized by approximately 30%.

## 5.4.5

### Quick battery size calculation

A very simple and quick way to calculate the required battery capacity is to add up the Ah-values from the table below. This includes 30% battery oversize and it doesn't matter whether the amplifiers are 4-channel or 8-channel amplifiers, how many channels are in use or what the loudspeaker load is, nor how many call station extensions are used, whether it is used to make alarm calls or not, nor how many Ethernet ports are used. These details have only a relatively small impact on the ultimate battery capacity needed and the Ah-values are rounded up to include them all.

Device	Battery requirement	
	24 h quiescent + 0.5 h alarm	30 h quiescent + 0.5 h alarm
System controller	17 Ah	21 Ah
Call station with extensions	21 Ah	26 Ah
Amplifier	40 Ah	47 Ah
Multifunction power supply	21 Ah	25 Ah
Ambient noise sensor	5 Ah	6 Ah
Control interface module	13 Ah	16 Ah
Wall control panel	4 Ah	5 Ah

According to this simple table, the system described in the previous section would get a backup battery of  $17 + 21 + 40 + 40 + 40 + 21 \text{ Ah} = 179 \text{ Ah}$  when used for 24 h in quiescent condition and 30 minutes in alarm condition. The accurate calculation resulted in 170 Ah. The additional benefit of this approach is that relatively small system changes, such as adding load to an amplifier, can easily be made without changing the already installed battery capacity.

The minimum installed battery capacity should be 100 Ah to have a sufficiently low internal impedance of the battery to accommodate peak current draw from connected amplifiers. The maximum installed battery capacity is 230 Ah to be able to charge the battery within the permitted time according to EN 54-4 or similar standards.

The maximum current draw from the battery would be approximately 70 A in alarm mode without taking the losses of the battery cables, battery internal resistance, fuse and connections into account. With the supplied battery cables and fuse, and assuming that the internal resistance of the battery is 3.5 mohm, the total series resistance is approximately 6 mohm. The 70 A current creates a loss of 0.42 V across this resistance, so the 12 V would drop to 11.58 V, making the supply voltage of the system, approximately 4% lower. Because all PRAESENSA devices use DC/DC converters that take the required power regardless of small deviations of the supply voltage, the 4% lower voltage is compensated by drawing 4% more current, so approximately 73 A. Because of this, the voltage drops a bit more and the current increases a bit more again. This shows the high importance of keeping the series resistance of the battery connections as low as possible. In quiescent conditions the current from the battery is hardly 4 A, worst case, so the cable losses are low ( $<0.1 \text{ W}$ ), but at maximum output power, the battery cable losses go up to 30 W, causing the cables to warm up. Also see section *Battery and fuse, page 137*.

## 5.4.6

### Uninterruptable power supply size calculation

An alternative for the use of the multifunction power supply with built-in battery charger and converter, is to use the PRA-PSM48 to power PRAESENSA. This solution is not compliant to EN 54 / ISO 7240, but still useful for non-certified solutions. In this case the system controller PRA-SCL and Ethernet switch PRA-ES8P2S can be powered from a PRA-PSM48 power supply module. The PRA-CSLD and PRA-CSLW can be powered via PoE from the PRA-ES8P2S. The amplifiers PRA-AD604 and PRA-AD608 can also be powered from a PRA-PSM48, not more than one amplifier per power supply. Also with this setup it is possible to have battery backup power by using an uninterruptable power supply (UPS) to provide uninterruptable mains power to the PRA-PSM48 power supply modules.

The required capacity of the UPS can be calculated in the same way as for the backup battery of the multifunction power supply. Because the efficiency of the PRA-PSM48 power supply modules is comparable to the efficiency of the DC/DC converters in the multifunction power supply, take the data from the column "Power from battery [W]" in the table of *Power consumption, page 59*. This is also the approximate amount of mains power that is taken by the PRA-PSM48, when it is powering the connected device or devices in the mode or configuration that is specified in this table. To calculate the required battery capacity or energy storage, the power consumption must be multiplied by the time that the devices are powered in a specific mode, similar to what was done for the accurate battery size calculation in *Accurate battery size calculation, page 61*. However, in this case the amplifiers cannot run in snooze mode, but will run in idle mode while not being active. The snooze mode is only available in combination with the multifunction power supply. In idle mode the power consumption of the amplifiers is considerably higher than in snooze mode and this will have an impact on the required backup power capacity of the UPS.

As an example, consider a voice alarm system that consists of the devices in the table below. This small system has a system controller, one call station and three amplifiers; furthermore, it has an Ethernet switch to connect and power the call station via PoE, because this system doesn't have a multifunction power supply. This system can be powered from four PRA-PSM48 power supply modules, one for each amplifier and one for the system controller and switch. The PoE load of the switch is not counted in the table as this power is already taken into account for the call station, the power is in fact passed through the switch.

For the required UPS capacity, the calculation is based on 24 h operation in quiescent mode, which is in this case the idle mode of the amplifiers, and 0.5 h operation in alarm mode for which the full power consumption of the amplifiers is taken. It is clear that most of the UPS capacity is needed to keep the system alive during the 24 h in quiescent mode, the energy consumption during the much shorter alarm mode is less. If this system would use the PRA-MPS3 multifunction power supply, the amplifiers would be able to run in snooze mode during these 24 h and the total energy consumption and associated battery size would be much lower.

This system requires a UPS that can deliver at least 5.3 kWh of energy. Also, the UPS must be capable of providing at least 811 W of instantaneous power, so a 1 kW UPS, with 6 kWh of energy stored in batteries seems to be a good choice. It depends on how the aging of the batteries and Peukert's law has been taken into account by the manufacturer of the UPS, whether this 6 kWh capacity is really sufficient or that 7 kWh would be a better choice.



Device	Device elements	Power taken from mains [W]	Time in quiescent mode [h]	Time in alarm mode [h]	Power x time [Wh]	Maximum power [W]
PRA-SCL	System controller + per active port (2)	4.2	24	0.5	103	4.2
		2 x 0.5	24	0.5	25	2 x 0.5
PRA-CSLD	Call station	5.0	24	0.5	123	5.0
	+ per active port (2)	2 x 0.6	24	0.5	29	2 x 0.6
	+ per extension PRA-CSE (3)	3 x 0.1	24	0.5	7	3 x 0.1
	+ with alarm option	1.5	24	0.5	37	1.5
PRA-ES8P2S	Ethernet switch	8.4	24	0.5	206	8.4
	+ per active RJ45 port (2)	2 x 0.5	24	0.5	25	2 x 0.5
	+ per active SFP port	0.8	-	-	-	-
	+ PoE load	PRA-CSLD	-	-	-	-
PRA-AD604	Amplifier (active, idle)	43	24	-	1032	-
	Amplifier (active, low power)	60	-	-	-	-
	Amplifier (active, full power)	244	-	0.5	122	244
	+ per active port (2)	2 x 0.4	24	0.5	20	2 x 0.4
PRA-AD608	Amplifier (active, idle)	68	24	-	1632	-
	Amplifier (active, low power)	93	-	-	-	-
	Amplifier (active, full power)	271	-	0.5	136	271
	+ per active port (2)	2 x 0.4	24	0.5	20	2 x 0.4
PRA-AD608	Amplifier (active, idle)	68	24	-	1632	-
	Amplifier (active, low power)	93	-	-	-	-
	Amplifier (active, full power)	271	-	0.5	136	271
	+ per active port (2)	2 x 0.4	24	0.5	20	2 x 0.4
<b>Minimum required backup power capacity of UPS [Wh]</b>					<b>5305</b>	
<b>Minimum output power capability of UPS [W]</b>						<b>811</b>

## 5.5 Heat loss calculation

To be able to calculate the required cooling capacity of a cooling system for a technical room with equipment to stay within temperature limits of the equipment, the heat production must be known and the maximum ambient temperature that the equipment is allowed to operate in.

The maximum ambient operating temperature of PRAESENSA rack-mounted devices is 50 °C (122 °F). The generated heat is the energy that is dissipated and released as heat by the equipment in the room. Energy is power multiplied by time, so the longer a certain amount of power is dissipated in the room the more heat is generated. The amount of energy is expressed in joule, calories or BTU, British Thermal Units. The amount of power is expressed in watt. By definition 1 joule = 1 watt x 1 second. Furthermore: 1 kJ = 0.948 BTU = 0.239 kcal.

The PRAESENSA system controller just dissipates some power that is taken from the power supply. This power turns into heat. The same is true for the call stations, but they are typically placed outside the technical room and do not contribute to heat production in the room. PRAESENSA power amplifiers dissipate some power that is taken from the power

supply, but when announcements are made or music is played through the system, the output power of the amplifiers is dissipated in the loudspeakers and the cabling to the loudspeakers. Because the loudspeakers and most of the cabling is not in the technical room with the equipment, this part should not be taken into account for the heat generation. Only the difference between the power that is taken from the power supply and the output power to the loudspeakers is actually dissipated as loss in the amplifier and contributes to the heat production.

When the PRAESENSA system is powered via multifunction power supplies (PRA-MPS3), also some power is dissipated in the AC/DC power converters that convert power from the mains to DC voltages for the connected devices. The amplifiers and the power supplies are the only devices that contribute significantly to the heat production, the contribution of other PRAESENSA devices is negligible. It is easiest to incorporate the losses of the power supplies into the power dissipation data of the amplifiers. Because the normal situation is that the system is running from mains power, this is the operational mode to consider for heat calculations. During operation from a battery, the system switches to a power saving mode (sleep mode or snooze mode), on average resulting in less heat.

The table below then shows the heat loss related data for the amplifiers, in different operating modes.

Device	Mode	Dissipated power [W]	Heat loss [kJ/h]	Heat loss [BTU/h]	Heat loss [kcal/h]
PRA-AD604	Amplifier (active, idle)	43	155	147	37
	Amplifier (active, low power)	60	216	205	52
	Amplifier (active, full power)	94	339	321	81
PRA-AD608	Amplifier (active, idle)	68	245	232	59
	Amplifier (active, low power)	93	335	318	80
	Amplifier (active, full power)	121	434	412	104

This data can be further simplified by assuming that in most systems the amplifiers are used for background music and occasional calls, that full power alarm tones have a relatively short duration (less than an hour) and that the heat production of the PRA-AD604 and PRA-AD608 is not so different. Then the following rounded numbers are sufficient for heat loss calculation. Just count the number of amplifiers in the rack or room for which the heat production must be calculated and use the data from the table below.

	Dissipated power [W]	Heat loss [kJ/h]	Heat loss [BTU/h]	Heat loss [kcal/h]
Per amplifier	100	360	340	90

When amplifiers are powered from a PRA-PSM48 power supply, also the heat loss of that power supply can be ignored, because it is already included in the heat loss of the connected amplifier.

## 6 From installation to configuration

To configure the system, an Ethernet connection is required between the configuration PC and the system controller. Then access the device's webserver through its URL using a browser.

For general and detailed system configuration instructions, see the PRAESENSA configuration manual.

### 6.1 MAC-addresses and hostname

All OMNEO connected PRAESENSA devices use one or two MAC-addresses and have a device hostname; the system controller also has a control hostname to get access to its webserver.

The MAC-addresses are in the Bosch Security Systems vendor range 00:1c:44:xx:xx:xx or in the Audinate vendor range 00:1d:c1:xx:xx:xx. In many corporate networks the MAC-addresses of networked devices need to be entered in a table in the DHCP-server, to allow access. For that purpose the MAC-addresses of each PRAESENSA device are printed on the product label:

- The system controller has two MAC-addresses and two hostnames. The device MAC-address and the Control MAC-address (C-MAC) are both in the Bosch Security Systems vendor range. The device hostname, of for example the PRA-SCL, is derived from the MAC-address: PRASCL-xxxxxx.local, with xxxxxx being the last 6 hexadecimal digits (3 octets) of the MAC-address. The domain name label 'local' is used as a pseudo-top-level domain for hostnames in local area networks that can be resolved via the Multicast DNS name resolution protocol. It is possible to ping a system controller via this name (for example: PRASCL-xxxxxx.local). The system composition webpage does not show the .local extension; this is implicit. The control hostname is the same as the device hostname, but with a postfix -ctrl. So, it becomes for example: PRASCL-xxxxxx-ctrl.local. To get access to the webserver, of for example, the PRA-SCL, this address is used as URL (Uniform Resource Locator). This address is also used for the Open Interface.
- The PRA-AD604 and PRA-AD608 only have a MAC-address in the Bosch Security Systems vendor range. Their hostname is PRAAD604-xxxxxx.local or PRAAD608-xxxxxx.local.
- The PRA-MPS3 only has a MAC-address in the Audinate vendor range. The hostname is: PRAMPS3-xxxxxx.local.
- The PRA-CSLD and PRA-CSLW have two MAC-addresses, but only one hostname. Its device MAC-address in the Audinate vendor range and its C-MAC address is in the Bosch Security Systems vendor range. The device hostname is derived from the device MAC-address: PRACSLD-xxxxxx.local or PRACSLW-xxxxxx.local.
- The PRA-CSE and PRA-EOL do not have a MAC-address, nor hostname.

#### Remarks:

- The program OMNEO Control only shows device hostnames, not the control hostname of a system controller.
- The configuration webpages show device hostnames without .local domain extension. It does not show control hostnames, neither the one of its own web server, nor from other system controllers.
- Both MAC-addresses of the system controller and call station are on the same printed circuit board (PCB), so in case of PCB exchange both MAC-addresses will change and also the derived host name(s).
- The Firmware upload tool (FWUT) addresses the devices via their device hostname.
- The configuration of all devices is described in the PRAESENSA configuration manual.

## 6.2 Connecting the system controller

Perform the following steps to get access to the PRAESENSA system controller:

1. Install the Firmware Upload Tool on the PC, then automatically also the Bosch DNS-SD Service is installed. This service is needed to access PRAESENSA devices via their hostname instead of the IP-address.
2. Connect a network cable between the Ethernet network port of the PC and connect to one of Ethernet ports of the PRAESENSA system controller, or to a network port of another native PRAESENSA device that is connected to the same network, such as the PRA-AD60x amplifiers, PRA-MPSx multifunction power supplies or PRA-CSLx call stations.



### Notice!

Do not connect the configuration PC to a port of any other device on the same network, such as the (Advantech) PRA-ES8P2S Ethernet switch or any other Ethernet switch.

3. When a DHCP-server is present on the network the PRAESENSA devices will already have an IP-address, otherwise a Link-Local address will be assigned.
4. Some PC settings of (corporate) PCs may prohibit automatic Link Local addressing for the PC. Then this must be done manually. For Windows 10 the procedure is as follows:
  - Click Internet settings in the taskbar, then go to Network & Internet settings.
  - Select Wi-Fi and switch off Wi-Fi.
  - Select Ethernet, then go to Change adapter options.
  - Double click Ethernet and select Properties.
  - Check Internet Protocol Version 4 (TCP/IPv4), then select Properties.
  - Select Use the following IP-address and enter 169.254.1.1 with mask 255.255.0.0. This is a Link-Local address.
5. Open a browser on the PC, e.g. Firefox. Make sure no proxy is used. To disable using a proxy, do as follows:
  - Select Open menu, then select Options.
  - Select Network proxy, then select Settings.
  - Select No proxy.
6. If for example the PRA-SCL system controller is connected, type `https://prascl-xxxxxx-ctrl.local` in URL-bar. Read xxxxxx from the product label, e.g. `https://prascl-0b484c-ctrl.local`.



### Notice!

The system controller webserver uses secure HTTPS with SSL. The web server in the system controller uses a self-signed security certificate. When you access the server via https, you will see a Secure Connection Failed error or warning dialog indicating that the certificate was signed by an unknown authority. This is expected and to avoid this message in the future you have to create an exception in the browser.

See the PRAESENSA configuration manual for configuration of the system.

## 6.3 Network connections to devices

Except for some accessories, PRAESENSA devices must be connected to the OMNEO network in order to become part of the PA/VA system. Depending on the size of the system, there are different ways to do that.

### 6.3.1 Star topology

In this topology, the system controller is the central point and other devices are connected directly to one of the ports of the system controller. But, because the system controller has five ports, the system can only be very small. No call station can be connected because the system controller does not have ports that supply PoE.

Many wired home networks are wired like this with one central multi-port switch as central point. However, for a sound system this is not very useful.

### 6.3.2 Tree topology

A tree or 'combined star' topology is effectively an interconnection of multiple star networks. In modern networks this is the most used topology. In this topology the connection of devices depend on the connection of other devices in the network.

All PRAESENSA networked devices have a built-in Ethernet switch and at least two ports. Because of this, devices can easily be connected to a switch port of another device. Devices are then cascaded or looped through.

The system controller is still the central point of the network. A multifunction power supply is connected to one port of the system controller. A call station can be connected to a port of the multifunction power supply that provides PoE. An amplifier can be connected to another port of the system controller, but also to one of the ports of the multifunction power supply. Another amplifier can be connected to the first amplifier, and so on.

For every three amplifiers, a multifunction power supply is needed, which has a multi-port switch built in. So the connection possibilities grow with the system size. Not all devices need to be looped through in a single long string of devices, but parallel paths (branches) of shorter strings are possible. The use of branches reduces the risk that a failing connection of a devices close to the root of the tree disconnects all other devices. Still a single connection failure may cause more than one device to become disconnected from the system controller. And even though an amplifier might be connected to a call station, when both get disconnected from the system controller, the audio connection between the call station and the amplifier gets lost. The system controller is needed to set up and supervise the connections.

### 6.3.3 Ring topology

A next step in improving the connectivity of the devices is to use a ring topology. In this topology the devices are connected in one or more rings or closed loops. Normal Ethernet networks do not allow a topology with more than one physical path between two endpoints (e.g. multiple connections between two network switches or two ports on the same switch connected to each other). The loop creates broadcast storms as broadcasts and multicasts are forwarded by switches out of every port. The switch or switches will repeatedly rebroadcast the broadcast messages, flooding the network.

A physical topology that contains switching or bridge loops is attractive for redundancy reasons, yet a switched network must not have loops. The solution is to allow physical loops, but create a loop-free logical topology using a protocol that disables redundant connections until they are needed because another connection failed. RSTP is such a

protocol and all PRAESENSA networked devices support RSTP. Connecting and disconnecting redundant loops take some time to be processed in the network and as a result active audio connections will be muted during that time.

The system controller is still the central point, it is the so-called root bridge. Amplifiers can be looped through and a ring of amplifiers can then be connected between two ports of the system controller. In the same way a number of multifunction power supplies can be looped through and a ring of these devices can be connected between the two other ports. Call stations can be connected to a multifunction power supply via a double connection to two PoE ports, or even to two different multifunction power supplies. This is the recommended way of connecting PRAESENSA devices and mandatory for PA/VA systems that need to be compliant to voice alarm standards.

### 6.3.4

#### **Hop count**

When data passes through (PRAESENSA) network devices between source and destination, a hop occurs for every device that is passed. In PRAESENSA the relevant portion for hop counting is the network path between the root (the system controller) and any possible end point via the shortest path.

This is important because there is maximum to the number of hops that are allowed for proper communication. This has to do with the latency that occurs in every hop and every connection. There is a limit of 22 hops. Devices that are connected after the 22<sup>nd</sup> hop are lost in the system. Also loops, connected to the system controller, should not contain more than 22 devices. A loop with 43 devices, connected to the system controller, works fine as long as the loop is not interrupted, because the device in the middle of the loop has a hop count of 22 towards the system controller in both directions. All other devices have a smaller hop count. But if one link in the loop fails, this results in two branches being connected to the system controller, and one of them will have more than 22 looped-through devices. Then the devices after the 22<sup>nd</sup> will be lost. So, always consider the worst case hop count for a device in case a connection would fail. This must be carefully analyzed for larger systems.

The performance of a network will be better if the number of loops is smaller. The RSTP recovery time of the network after a link failure increases when the number of loops is higher. So, the hop count must be balanced against the number of loops.

## 6.4 Device status and reset

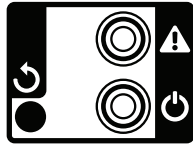

### Status

	Device fault present	Yellow		Power on	Green
	Identification mode / Indicator test	All LEDs blink			

All PRAESENSA 19"-devices have a small section on their rear panel for status monitoring, comprising a:

- Green LED to show the device is powered. The green LED will blink when the device is in identification mode during configuration.
- Yellow LED to show that a device fault is present. This may be convenient during installation and servicing.

### Reset

	Device reset (to factory default)	Button			
--	-----------------------------------	--------	--	--	--

A pinhole gives access to the hidden reset switch. This switch resets the device to its factory default settings. It clears the OMNEO pre-shared key (PSK) for secure connections and clears the complete local configuration and reference data.

For the system controller it also clears the complete system configuration, all messages, user authentication information, security certificates, time zone, NTP settings and all event logs!

For the call stations, the reset switch is below the cable cover, as indicated. It functions in the same way as the reset switch of the 19"-devices.

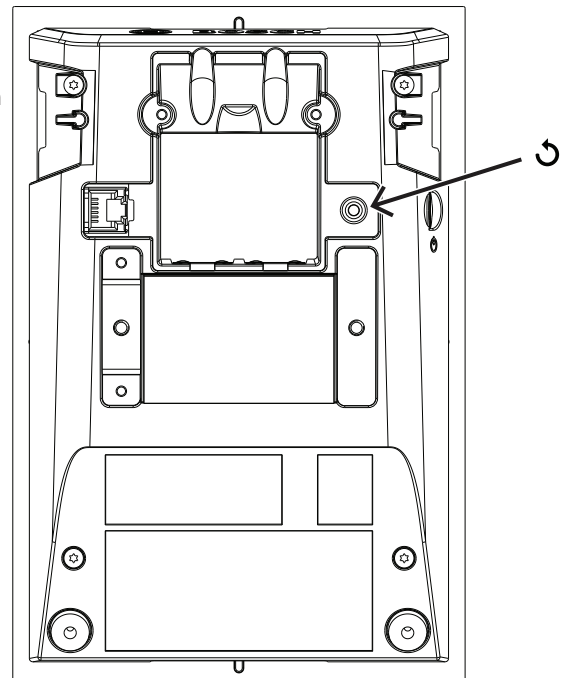

For the call station kit, the reset switch is on the topside of the printed circuit board, as indicated.

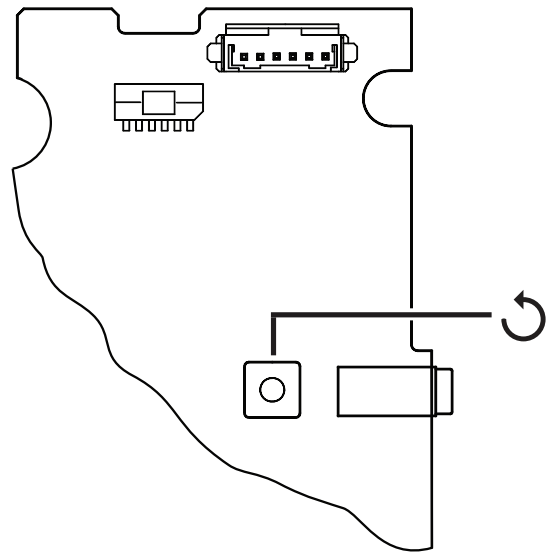

For the ambient noise sensor, the reset switch is under the removable front cover, as indicated.

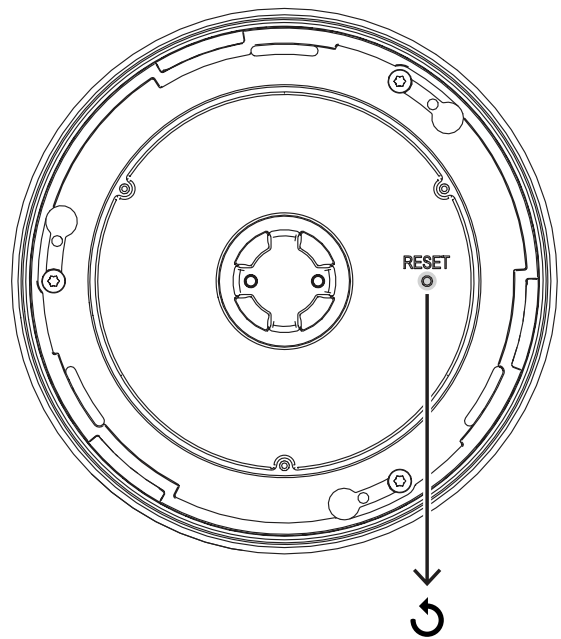



For the control interface module, the reset switch is on the front plate, as indicated.

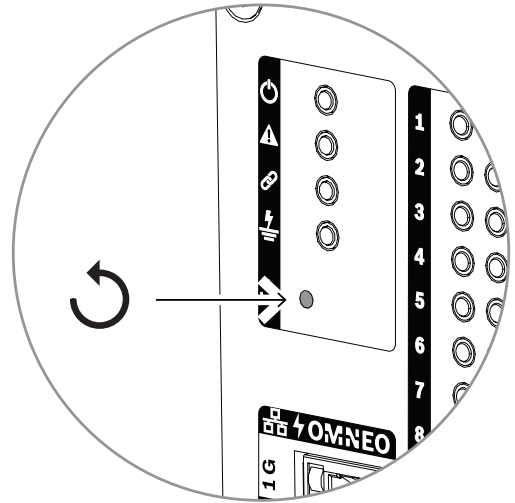

For the wall control panels, the reset switch is behind the wall plate, as indicated.

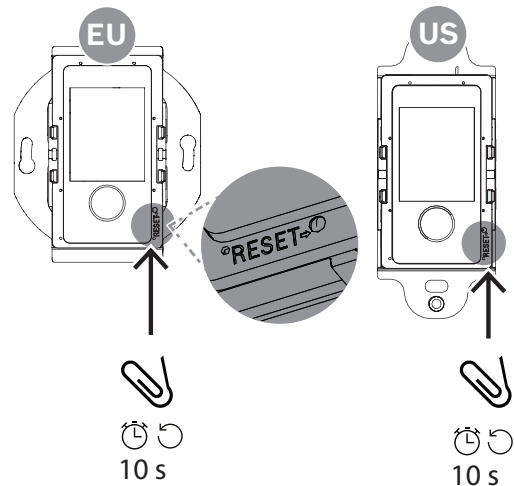

**Notice!**

This function is only to be used in case a device is removed from one system to become part of another system and is secured by an unknown PSK, that prevents discovery of the device in the new system.

To activate this function:

1. Use a pin or toothpick to press and hold the reset button for more than 10 s. After 10 s the LEDs of the device start flashing.
2. Release the reset button and the device will be reset to the factory default setting.

**Indicator test**

The reset switch can also be used to do an indicator test for this device.

To activate this function:

1. Use a pin or toothpick to press the reset button briefly. This will start the indicator test (LED test):
  - All LEDs will cycle through their possible color modes.

- Make sure to release the switch within 10 s, otherwise the device will be **reset** to the factory default!
2. Pressing the reset button again will stop the indicator test.

## 6.5

### Compatibility and certification overview

The table shows the products that can be part of a PRAESENSA system and the minimum required software version of PRAESENSA for each of these products. The table also shows for which emergency sound standards these products are certified. Due to ongoing certification activities, the table is subject to change. For the latest information, check the certificates in the download section of these products on [www.boschsecurity.com](http://www.boschsecurity.com).

Product	SW version	EN 54	ISO 7240	UL 2572	DNV-GL
PRA-PSM24			–		
PRA-PSM48		–			✓
PRA-ES8P2S PRA-SFPLX PRA-SFPSX	–			✓	
PRA-SCL PRA-AD608 PRA-EOL PRA-MPS3 PRA-CSLD PRA-CSLW PRA-CSE	1.00			✓	
PRA-EOL-US PRA-FRP3-US	1.00	–		✓	–
PRA-AD604	1.10			✓	
PRA-ANS	1.40	✓			–
PRA-CSBK PRA-CSEK	1.41			–	
OMN-ARNIE OMN-ARNIS IE-5000-12S12P-10G	1.50	✓			–
PRA-IM16C8 PRA-SCS	1.91	✓			–
PRA-WCP-EU PRA-WCP-US	2.00			–	

## 7 System controller (SCL, SCS)



### 7.1 Introduction

The system controller manages all system related functions in a PRAESENSA Public Address and Voice Alarm system. It routes all audio connections between network-connected PRAESENSA audio sources and destinations. It supervises and plays back messages and tones, stored on its flash memory, either scheduled or manually started from a call station or PC. It manages the routing of background music streams, along with business calls and emergency calls, all based on priority level and zone occupancy. It collects all status information of connected system devices, manages the event logs and reports faults. The system controller is network-connected via OMNEO and DC-powered from a multifunction power supply with integrated battery backup, accommodating both centralized and decentralized system topologies. Connections to other devices in the system are made using the built-in 5-port switch, supporting RSTP. The built-in web server allows for system configuration using a browser.

### 7.2 Functions

#### System control and audio routing

- Capability to control a system with up to 250 devices, serving more than 500 zones.\*\*
- Native support for switched single-subnet networks, with add-on support for routed multi-subnet topologies.
- Dynamic allocation of multiple and simultaneous audio channels to save on network bandwidth; audio connections are created when a call or a message is broadcast, and freed up immediately afterwards.
- Secure interconnections using Advanced Encryption Standard (AES128) for audio data and Transport Layer Security (TLS) for control data.
- Receiver for Dante or AES67 audio channels from external sources, with dynamic re-routing to open or secure OMNEO channels.\*\*
- SIP/VoIP interface for telephone paging and for audio to PRAESENSA and control from 3<sup>rd</sup> party systems.
- Internal storage capacity for messages and tones; up to eight messages can be played back simultaneously.
- Internal real time clock for scheduled events and event time stamping; support for Network Time Protocol (NTP) with automatic adjustment for Daylight Saving Time (DST).
- Internal system event and fault event log.
- Networked control interface for third party applications.
- Built-in webserver for configuration and file management using a browser.
- Dual redundant system controller option for highest system availability in mission-critical applications.
- Recording facility on SD-card for emergency audio logging and call stacking. The integrated call stacker automatically forwards recorded calls to previously occupied zones.\*

**Sound quality**

- Audio-over-IP, using OMNEO, the Bosch high-quality digital audio interface, compatible with Dante and AES67; audio sample rate is 48 kHz with 24-bit sample size.
- Messages and tones are stored as high definition uncompressed wav-files.

**Supervision**

- Supervision of stored messages and tones.
- Supervision of data integrity of site specific data.
- Internal watchdog timers to detect and recover from processing errors.
- Faults or problems of all system devices are collected, reported and logged.

**Fault tolerance**

- Five OMNEO network connection ports, supporting RSTP.
- Dual DC-inputs with polarity reversal protection.
- Two system controllers can be configured as a redundant pair.

\* Availability to be announced.



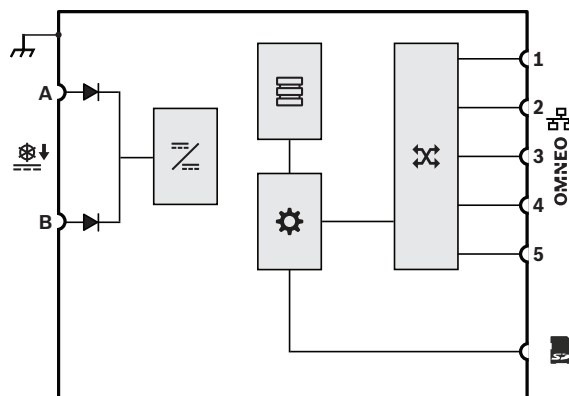

\*\* Limitations apply for the PRA-SCS.

## 7.3 Functional diagram

### Functional and connection diagram



### Internal device functions

-  Diode
-  DC to DC converter
-  Message and tone storage
-  Controller
-  OMNEO network switch

## 7.4 System controller variants

Two system controller variants are available:

- The PRA-SCL for medium to large systems
- And the PRA-SCS for small systems.

The small system controller PRA-SCS is the budget variant in the range of PRAESENSA system controllers. The small controller has all the features of the large system controller PRA-SCL except for some limitations regarding the size of the system.

- Capability to control PRAESENSA systems with a maximum of six amplifiers. In combination with the PRA-AD608 amplifiers, the PRA-SCS is sufficient to control up to 48 zones. Use the PRA-SCL to address more zones or if you need more power.
- The number of dynamic OMNEO channels that can be routed is unlimited, which allows for many simultaneous calls. However, the number of static Dante audio streams to use as interface with 3<sup>rd</sup> party systems is limited to eight.

<b>Variant</b>	<b>PRA-SCL</b>	<b>PRA-SCS</b>
Dynamic OMNEO audio channels (secure)	Unlimited	Unlimited
Dynamic OMNEO tone/ message playback channels (secure)	8	8
Static Dante or AES67 audio channels (secure, input and/ or output)	Pool of 8	Pool of 8
Static Dante or AES67 audio channels (open, input)	112	—
Number of amplifiers in the system	Unlimited	6

OMNEO channel routing is always dynamic and secure, with audio encryption in the transmitting device and decryption in the receiving device. Dante and AES67 channels are always static and not encrypted for easy compatibility between systems of different brands. Both of the PRAESENSA system controllers can either:

- Encrypt up to eight incoming streams to dynamic secure OMNEO streams
- Decrypt up to eight dynamic secure OMNEO streams to outgoing streams
- Or a mix of both with a maximum of eight.

In addition, the PRA-SCL can receive up to 112 Dante or AES67 channels that cannot be encrypted but are only converted to open dynamic OMNEO streams.

OMNEO streams are always dynamic multicast streams, routed from the transmitter to one or more receivers. The Dante and AES67 streams are static and received and/or transmitted by the system controller, where they are encrypted, converted or decrypted.

## 7.5 Indicators and connections



### Front panel indicators

	Device fault present	Yellow		Power on	Green
	Network link present Network link lost Standby for redundancy	Green Yellow Blue		Identification mode / Indicator test	All LEDs blink

### Rear view



### Rear panel indicators and controls

	SD card busy; do not remove	Green		100 Mbps network 1 Gbps network	Yellow Green
	Device fault present	Yellow		Power on	Green
	Device reset (to factory default)	Button		Identification mode / Indicator test	All LEDs blink

### Rear panel connections

	Chassis ground			24 to 48 VDC input A-B	
	Memory card			Network port 1-5	

## 7.6 Installation

The device can be connected everywhere within the PRAESENSA system. If required, refer to: *System introduction*, page 19.

The device is designed to be installed in a 19"-rack/cabinet. Refer to: *Mounting the 19"-rack devices*, page 27.

### 7.6.1

#### Parts included

The box contains the following parts:

Quantity	Component
1	System controller
1	Set of 19"-rack mounting brackets (pre-mounted)

Quantity	Component
1	Set of screw connectors and cables
1	Quick Installation Guide
1	Safety and security information

No tools, SD-card or Ethernet cables are provided with the device.

**Parts check and identification**

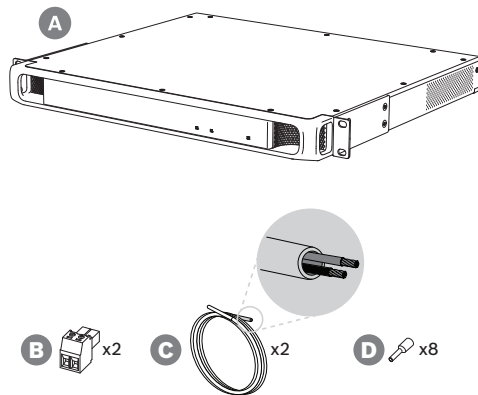

- A** System controller
- B** 2-pole screw plug (x2)
- C** 2-conductor cable (x2)
- D** Wire-end ferrules (x8)

**7.6.2**

**Memory card**

The SD memory card is optional and only used for call recording. Messages and tone files are stored in the internal memory.



**Notice!**

In a live system, do not remove the SD memory card while the system controller is accessing the card; this is indicated by the green busy-indicator. Removal of the card while busy may corrupt the card's file system.

For IP30 ingress protection compliance, the system controller is delivered with a plastic dummy SD card in the memory card slot. The dummy card must be removed before a real SD memory card can be inserted. If no SD memory card is used, leave the dummy SD card in place.

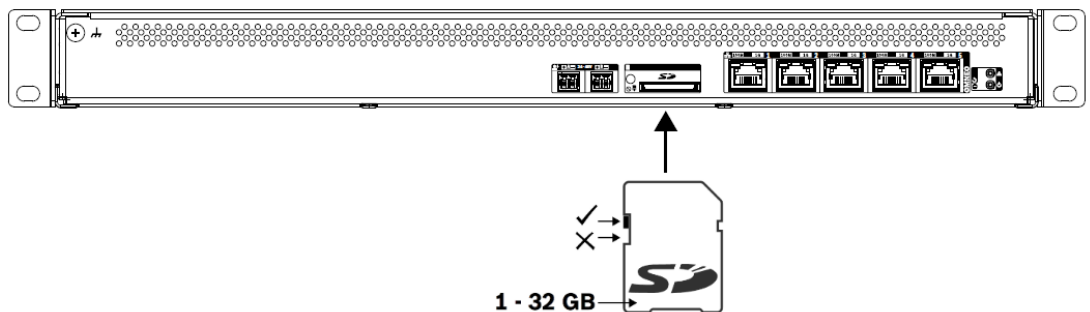

1. Use an SD memory card with a maximum size of 32 GB.
2. Disable write-protection of the card.
3. Insert the SD memory card in the slot.

### 7.6.3

#### Power supply

The system controller must be powered from a 24 - 48 V power supply. If the system controller is part of a certified emergency sound system, it must be powered from a PRAESENSA multifunction power supply. In case the system controller and the power supply are mounted in two different racks, double supply connections must be made. Even if both devices are in the same rack, it is recommended to use double connections for fail-safe redundancy.

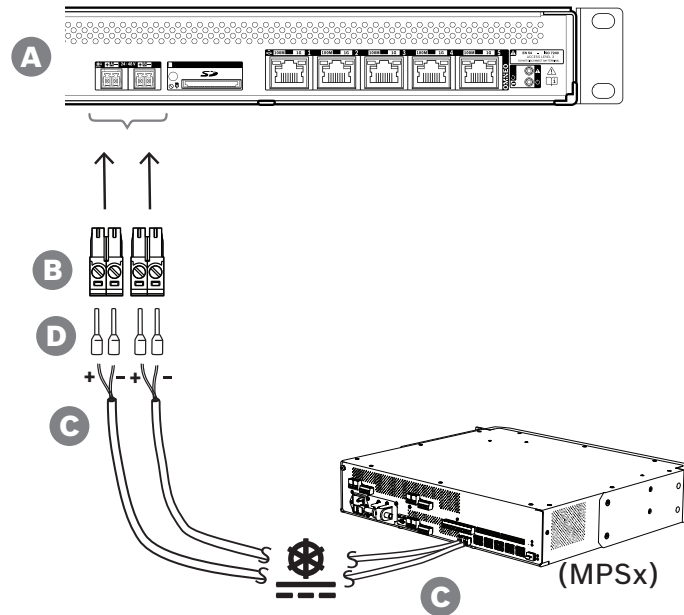

Follow the connection procedure below:

1. Crimp ferrules D onto the ends of the electrical wires of cable C to provide a solid and reliable electrical connection. Use a dedicated crimping tool.
2. Insert each wire into the appropriate slot of the connector B, observing polarity. Wiring color convention: red for + and black for -. Use a flat blade screwdriver to tighten each connection.
3. Insert the cable into the 24 to 48 V input A, cut the cable to length and mount the connector of the powering device to the other end of the cable, again observing polarity. Insert this connector into output A of the powering device (e.g. the 24 V output of the PRA-MPS3).
4. For redundancy, repeat these steps for a second cable to connect output B of the powering device to input B of the system controller.
5. Alternatives:
  - Instead of using the A/B outputs of a PRAESENSA powering device, also two separate power supplies can be used. The maximum current rating of the supply connectors is 8 A; only use a 24 - 48 V power supply that is current limited to < 8 A, also in overload condition.
  - When no power supply redundancy is required, a single power supply can be used.



#### Notice!

For compliance to EN 50121-4 for railway applications, the power connections to the 24-48 V input may not be longer than 3 m.



## 7.6.4

### Ethernet network

The system controller has five Ethernet connection ports with a built-in Ethernet switch, supporting RSTP. Follow the procedure below to connect the system controller to a network and other system devices.

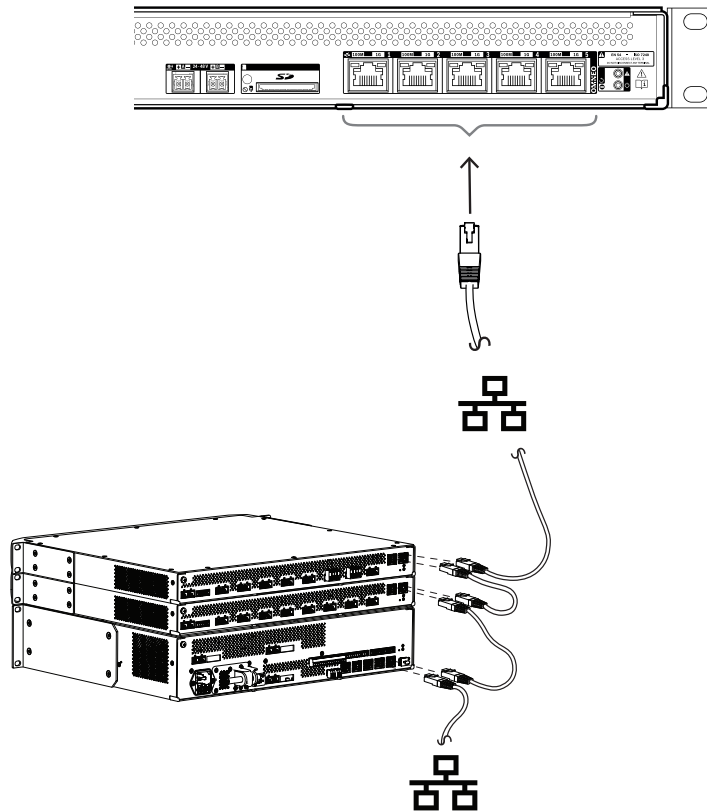

1. Use shielded Gb-Ethernet cables (preferably CAT6A F/UTP) with RJ45 connectors to connect the system controller to a network.
2. Connect to any of the five switch ports of the system controller.
  - The system controller supports Rapid Spanning Tree Protocol (RSTP) to enable the use of multiple connections simultaneously for cable redundancy, e.g. to daisy-chain devices in a loop, with a maximum of **21** devices in a loop.
  - RSTP can be disabled in the system configuration in case a (corporate) network does not allow for this.
3. Port assignments:
  - For general purpose Public Address systems all ports 1-5 can be used.
  - For Voice Alarm systems use ports 1-4 for (redundant) connections to the Voice Alarm network part, including all other PRAESENSA devices. Use port 5 for auxiliary connections, not related to the Voice Alarm function, like to a background music server.
  - The PRAESENSA system controller can be set up to work on two completely separate networks simultaneously for fail-over redundancy, supporting Dante glitch-free audio switching between both networks for continuous and uninterrupted audio distribution in case of a network failure of one of the networks. In this mode, use ports 1-4 for the primary network (with RSTP) and

port 5 for the secondary network. All PRAESENSA devices are on the primary network, the secondary network is only for network redundancy of Dante devices. Also see section *Network redundancy*, page 39.

- To configure the system, access to the webserver of the system controller is needed, using a web browser and the URL (Uniform Resource Locator) of the system controller. The URL is printed on the product label and for a PRA-SCL it has the following format: `https://prascl-xxxxxx-ctrl.local`, with `xxxxxx` being the last 6 hexadecimal digits of the device MAC-address. Configuration of the system and its devices is described in the PRAESENSA configuration manual.

## 7.6.5

### Internal battery

The system controller has an internal lithium coin cell battery, model CR2032 (3 V, 225 mAh), in a battery holder. It is only used to power the internal real time clock (RTC) when the system controller is off. The life-time of the battery is in that case more than 20 years. When the system controller is on, the RTC is powered from the external power supply and the CR2032 battery is not used, making the system unsusceptible to spring contact bounce of the battery holder in case of heavy vibrations.

Even when the system time is under control of an NTP server, the battery must not be removed, because it is important to keep the real time clock (RTC) powered during system restarts, keeping event logs in chronological order. Storage of system data does not depend on the presence of the battery.

#### In case battery replacement is needed:

1. Disconnect all power supply connections to the system controller.
2. Remove the system controller from the mounting rack and remove the top cover.
3. Locate the battery on the main printed circuit board, behind Ethernet port 5.
4. Replace the battery with the same type: CR2032 (3 V, 225 mAh). Observe polarity.
5. Assemble in reverse order.
6. Always comply with local requirements for hazardous waste when disposing the old battery.



#### Warning!

Keep lithium coin batteries out of the reach of small children; coin cell batteries can be accidentally ingested. If ingested, these batteries may leak harmful contents causing chemical burns, perforation of soft tissue, and in severe cases may cause death. Lithium coin batteries must be removed immediately if swallowed. Seek medical attention immediately.

## 7.6.6

### Reset to factory default

The reset switch resets the device to its factory default settings. This function is only to be used in case a secured device is removed from a system to become part of another system. See *Device status and reset*, page 71.

## 7.7

### Approvals

Emergency standard certifications	
Europe	EN 54-16 (0560-CPR-182190000)
International	ISO 7240-16
Maritime applications	DNV GL Type Approval (PRA-SCL only)
Mass Notifications Systems	UL 2572 (PRA-SCL only)
Control Units and Accessories for Fire Alarm Systems	UL 864 (PRA-SCL only)

Emergency standard compliance	
Europe	EN 50849
UK	BS 5839-8

Regulatory areas	
Safety	EN/IEC/CSA/UL 62368-1
Immunity	EN 55035 EN 50130-4
Emissions	EN 55032 EN 61000-6-3 ICES-003 FCC-47 part 15B class A EN 62479
Environment	EN/IEC 63000
Railway applications	EN 50121-4

## 7.8

### Technical data

#### Electrical

Control	
Audio routing OMNEO channels	Unlimited
Tone/message playback OMNEO channels	8
External audio inputs and/or outputs Dante or AES67 channels	120 (PRA-SCL) / 8 (PRA-SCS)
Logging (internal storage)	
Call events	1000
Fault events	1000
General events	1000

Real Time Clock Accuracy (with NTP) Accuracy (no NTP) Daylight Saving Time (DST) Backup battery	< 1 s/yr off < 11 min/yr off Automatic CR2032 Lithium cell
Message/tone storage capacity Mono, uncompressed, 48 kHz, 16-bit Number of messages/tones	90 min > 1000
SD card size	1 – 32 GB
System size (PRA-SCL) Networked devices Zones	250 (single subnet) 500
Configuration	Web server/browser

**Power transfer**

Power supply input A/B Input voltage range Input voltage tolerance	24 – 48 VDC 20 – 60 VDC
Power consumption (24 V) Duty mode Per active port	3.9 W 0.4 W

**Supervision**

Run fault (watchdog reset)	All processors
System integrity Fault report time	< 100 s
Site specific data integrity Fault report time Supervised message storage	< 1 hour 90 min
Power supply input A/B	Undervoltage

**Network interface**

Ethernet  Protocol Redundancy	100BASE-TX, 1000BASE-T  TCP/IP RSTP
Audio/control protocol Network audio latency Audio data encryption Control data security	OMNEO 10 ms AES128 TLS

Ports	5
-------	---

<b>Reliability</b>	
MTBF (extrapolated from calculated MTBF of PRA-AD608)	1,000,000 h

**Environmental**

<b>Climatic conditions</b>	
Temperature	
Operating	-5 – 50 °C (23 – 122 °F)
Storage and transport	-30 – 70 °C (-22 – 158 °F)
Humidity (non-condensing)	5 – 95%
Air pressure (operating)	560 – 1070 hPa
Altitude (operating)	-500 – 5000 m (-1640 – 16404 ft)
Vibration (operating)	
Amplitude	< 0.7 mm
Acceleration	< 2 G
Bump (transport)	< 10 G (IEC 60068-2-27)

**Mechanical**

<b>Enclosure</b>	
Dimensions (HxWxD)	
With mounting brackets	44 x 483 x 400 mm (1.75 x 19 x 15.7 in)
Rack unit	19 in, 1U
Ingress protection	IP30
Case	
Material	Steel
Color	RAL9017
Frame	
Material	Zamak
Color	RAL9022HR
Weight	5.8 kg (12.8 lb)

## 8 Amplifier, 600W 4-channel (AD604)



### 8.1 Introduction

This is a flexible and compact multi-channel power amplifier for 100 V or 70 V loudspeaker systems in Public Address and Voice Alarm applications. It fits in centralized system topologies, but also supports decentralized system topologies because of its OMNEO IP-network connection, combined with DC-power from a multifunction power supply. The output power of each amplifier channel adapts to the connected loudspeaker load, only limited by the total power budget of the whole amplifier. This flexibility, and the integration of a spare amplifier channel, makes it possible to utilize the available power effectively and use less amplifiers for the same loudspeaker load, compared to using traditional amplifiers. Digital sound processing and control, adjusted to the acoustics and requirements of each zone, allow for better sound quality and speech intelligibility.

### 8.2 Functions

#### Efficient 4-channel power amplifier

- Transformerless, galvanically isolated, 70/100 V outputs for a maximum total loudspeaker load of 600 W.
- Flexible partitioning of the available output power across all amplifier channels to use it effectively, significantly reducing the amount of required amplifier power in a system.
- Cost and space saving, integrated, independent spare channel for fail-safe redundancy.
- Class D amplifier channels with two-level power lines for high-efficiency in all operating conditions; dissipation and heat loss is minimized to save on energy and battery capacity for backup power.

#### Flexibility in loudspeaker topologies

- A/B outputs on every amplifier channel to support redundant loudspeaker wiring topologies. Both outputs are individually supervised and disabled in case of a fault.
- Class A loop wiring possible between the A and B loudspeaker outputs. Dedicated connection facility for an end-of-line device to supervise the complete loop, including the B-output connection.
- Load independent frequency response; the amplifier channels can be used with any loudspeaker load up to the maximum, without any change in audio quality.

#### Sound quality

- Audio-over-IP, using OMNEO, the Bosch high-quality digital audio interface, compatible with Dante and AES67; audio sample rate is 48 kHz with 24-bit sample size.
- Large signal to noise ratio, wide audio bandwidth and very low distortion and crosstalk.
- Digital signal processing on all amplifier channels, including equalization, limiting and delay, to optimize and tailor the sound in each loudspeaker zone.

**Supervision**

- Supervision of amplifier operation and all of its connections; faults are reported to the system controller and logged.
- Loudspeaker line integrity supervision without interruption of audio, using end-of-line devices (separately available) for best reliability.
- Network link supervision.

**Fault tolerance**







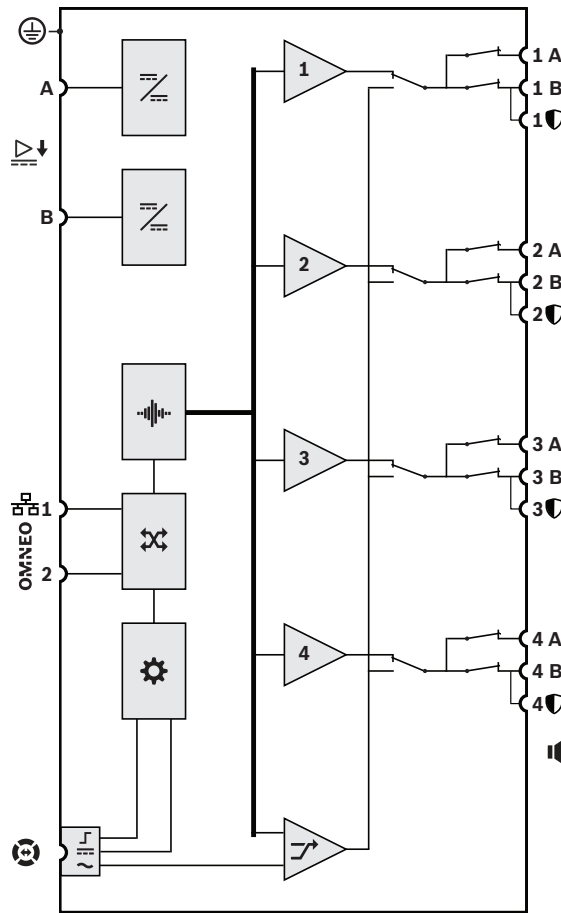

- Dual OMNEO network connections, supporting Rapid Spanning Tree Protocol (RSTP), for loop-through connections to adjacent devices.
- Dual 48 VDC inputs with polarity reversal protection, each with a full power DC/DC converter, operating in tandem for redundancy.
- Fully independent amplifier channels; the integrated spare channel automatically replaces a failing channel, with due regard of the actual sound processing settings.
- All amplifier channels support two independent loudspeaker groups, A and B, enabling redundant loudspeaker wiring topologies.
- Backup analog audio lifeline input driving the spare amplifier channel to serve all connected loudspeaker zones in case both network connections, or the amplifier network interface, would fail.

### 8.3 Functional diagram

Functional and connection diagram



Internal device functions

-  DC to DC converter
-  Audio processing (DSP)
-  OMNEO network switch
-  Controller
-  Lifeline control interface
-  Lifeline supply input
-  Lifeline audio input
- 1-4** Amplifier channel
-  Spare channel



## 8.4 Indicators and connections



### Front panel indicators

	Spare channel substitute 1-4	White		Signal present 1-4 Fault present 1-4	Green Yellow
	Ground fault present	Yellow		Device fault present	Yellow
	Audio lifeline substitute	White		Network link to system controller present Network link lost Amplifier in standby mode	Green Yellow Blue
	Power on	Green		Identification mode / Indicator test	All LEDs blink

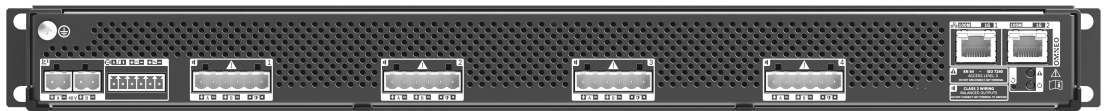

### Rear panel indicators and controls

	100 Mbps network 1 Gbps network	Yellow Green		Device fault present	Yellow
	Power on	Green		Device reset (to factory default)	Button
	Identification mode / Indicator test	All LEDs blink			

### Rear panel connections

	Safety ground			48 VDC input A-B	
	Lifeline interface			Loudspeaker output A-B (1-4) End-of-line device	
	Network port 1-2				

## 8.5 Installation

The device is designed to be installed in a 19"-rack/cabinet. Refer to: *Mounting the 19"-rack devices, page 27.*

The device can be connected everywhere within the PRAESENSA system. If required, refer to: *System introduction, page 19.*

### 8.5.1 Parts included

The box contains the following parts:

Quantity	Component
1	Amplifier, 600W 4-channel
1	Set of 19"-rack mounting brackets (pre-mounted)
1	Set of screw connectors and cables
1	Quick Installation Guide
1	Safety information

No tools or Ethernet cables are provided with the device.

#### Parts check and identification

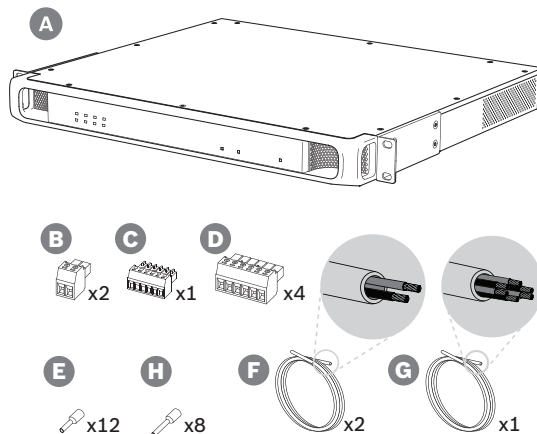

- A** Amplifier
- B** 2-pole screw plug (x2)
- C** 6-pole screw plug (small)
- D** 6-pole screw plug (large, x4)
- E** Wire-end ferrules (small, x12)
- F** 2-conductor cable (x2)
- G** 6-conductor cable
- H** Wire-end ferrules (large, x8)

### 8.5.2 Safety ground

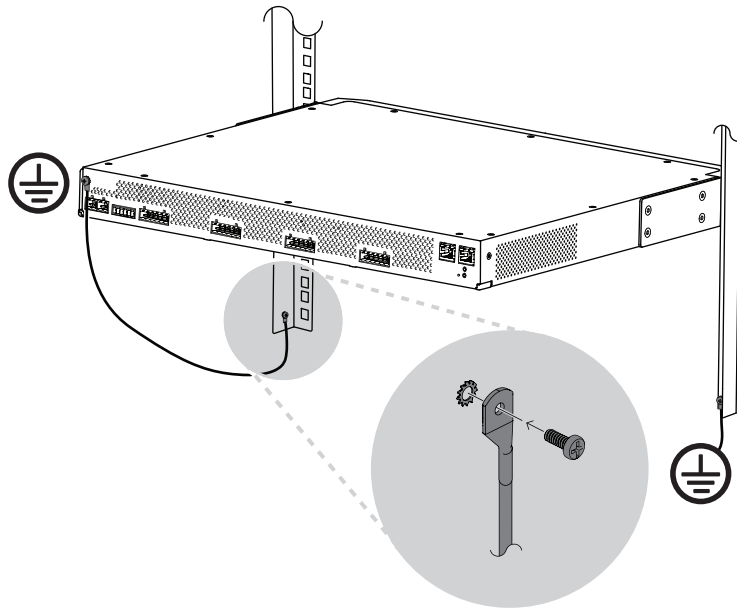

Connecting the chassis ground screw to safety ground is mandatory for the PRAESENSA power amplifiers:

- The safety ground connection is needed for safety because of high internal voltages. All PRAESENSA 19"-devices have a chassis ground screw on the rear panel, which can be used for a wire connection to the rack frame. The rack frame must be grounded to safety ground. This is a conductive path to ground or earth that is designed to protect persons from electrical shock by shunting away any dangerous currents that might occur due to malfunction or accident. Use a thick, multi strand wire (>2.5 mm<sup>2</sup>) with wire eyelets and washers for a solid connection.
- The safety ground connection is needed as reference for the ground short detection circuit. Without this connection, the amplifier could be electrically floating and no ground shorts or leakage currents would be detected for loudspeaker lines that touch ground somewhere. The safety ground connection via the mains connection of the multifunction power supply cannot be relied on for this, because the mains cable of this supply could be unplugged and then the amplifier continues to work on the backup battery.



**Caution!**

The chassis ground screw of an amplifier must be connected to protective ground **before** the amplifier is connected to a power supply.

### 8.5.3

#### Power supply

The amplifier must be powered from a 48 V power supply. If the amplifier is used as part of a certified emergency sound system, it must be powered from a PRAESENSA multifunction power supply. In case the amplifier and the power supply are mounted in two different racks, double power supply connections must be made, but even if both devices are in the same rack, it is recommended to use double connections for fail-safe redundancy.

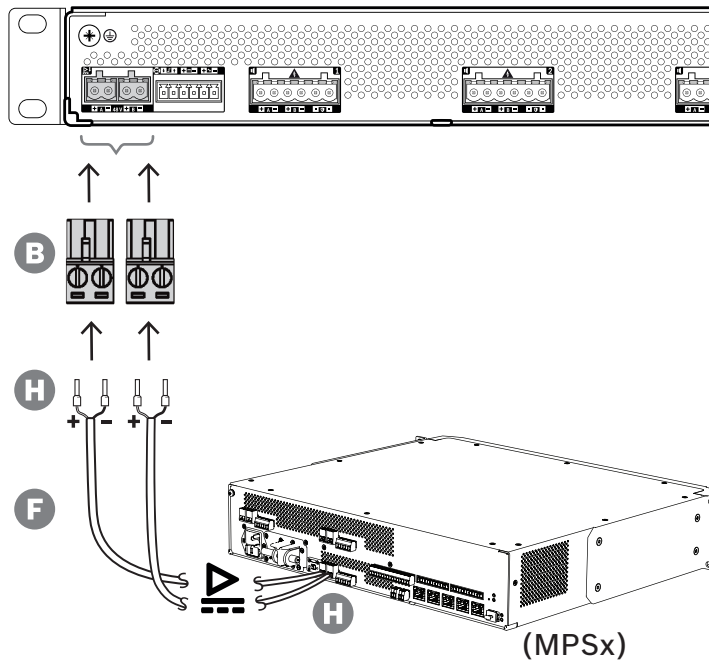

Follow the connection procedure below:

1. Crimp ferrules H onto the ends of the electrical wires of cable F to provide a solid and reliable electrical connection.
  - Use a dedicated crimping tool.
2. Insert each wire into the appropriate slot of the connector B, observing polarity. Wiring color convention: red for + and black for -.
  - Use a flat blade screwdriver to tighten each connection.
3. Insert the cable into the 48 V input A, cut the cable to length and mount the connector of the powering device to the other end of the cable, again observing polarity. Insert this connector into output A of the powering device.
4. For redundancy, repeat these steps for a second cable between output B of the powering device to input B of the amplifier.
5. Alternatives:
  - Instead of using the A/B outputs of a PRAESENSA powering device, also two separate power supplies can be used. The maximum current rating of the supply connectors is 15 A; only use a 48 V power supply that is current limited to < 15 A, also in overload condition.
  - When no power supply redundancy is required, a single power supply can be used; in that case connect the 48 V inputs A and B in parallel to make use of the amplifier's internal dual power converters for fail safe redundancy and to avoid a supply supervision fault event.

### 8.5.4

#### Lifeline

The lifeline is an optional cable connection between a PRAESENSA amplifier and a PRAESENSA multifunction power supply. This interconnection serves multiple functions:

- The multifunction power supply provides the audio signal of the highest priority emergency call as a balanced line level analog signal on the lifeline connector (pins 5 and 6). This signal is a backup audio signal for the connected amplifier in case its network interface or both network links would fail. The emergency call will then be distributed to all connected loudspeakers at maximum volume and without equalization or audio delay. The lifeline signal goes straight to the spare amplifier channel to drive all zones in parallel. This line is supervised by the multifunction power supply.
- The multifunction power supply sends information (pin 1) to the connected amplifier about the availability of mains power. In case mains power fails and power is provided from the battery, this signal sets the amplifier in backup power mode to disable all amplifier channels that are not needed to make calls with a priority above the configured priority level for the backup power mode. When no high priority calls are being made via this amplifier, it informs the multifunction power supply (pin 2) to switch off the 48 V converters to minimize battery power consumption even more. The power supplies and the amplifier channels go to snooze mode and wake up every 90 seconds briefly to perform the required supervision actions for timely fault reporting.
- The multifunction power supply provides the battery or charger voltage, in the range of 12 to 18 V, to the amplifier directly (pins 3 and 4) to supply power to the amplifier's network interface while the 48 V power supplies are switched off.



### Notice!

When the amplifier is powered from one or two normal 48 V power supplies, that do not have a lifeline interface, the power saving and audio bypass functions are not available. All other amplifier functions are still available.

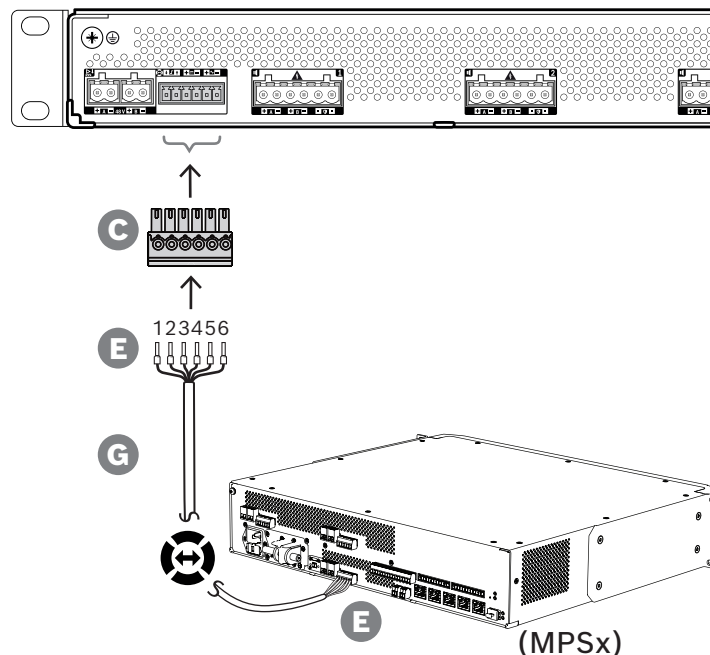

To create a lifeline connection, follow the procedure below.

1. Crimp ferrules E onto the ends of the electrical wires of cable G to provide a solid and reliable electrical connection.
  - Use a dedicated crimping tool.

2. Insert each wire into the appropriate slot of the connector C. The wiring order is not critical, but use the same order for all lifeline cables in the system to minimize the risk of errors.
  - Use a flat blade screwdriver to tighten each connection.
3. Insert the cable connector into the amplifier's lifeline socket, cut the cable to length and mount a connector of the same type, delivered with the multifunction power supply to the other end of the cable, observing wiring order. Insert this connector into the lifeline socket of the multifunction power supply.

**Notice!**

The lifeline connection may not be longer than 3 m.

**8.5.5****Amplifier outputs**

The amplifier provides four output channels and a spare channel that substitutes a failing channel.

The channels have direct drive 70/100 V outputs for low distortion, low crosstalk and a wide audio bandwidth. There are no output transformers that would be a limiting factor for the output power of each channel. Every channel also has a load independent flat frequency response. This combination of features makes it possible to partition the available amplifier power across all channels and utilize that power effectively.

Every channel has a 6-pole connector socket, providing independently switched loudspeaker group A and group B outputs and a separate connection facility for an End-of-Line device for loudspeaker cable supervision (only for Class-A loop, A to B).

**Caution!**

For compliance to UL 62368-1 and CAN/CSA C22.2 No. 62368-1 all loudspeaker wiring must be Class 2 wiring (CL2); this requirement does not apply for compliance to EN/IEC 62368-1.

**Caution!**

Amplifier outputs may carry output voltages up to 100 VRMS. Touching uninsulated terminals or wiring may result in an unpleasant sensation.

**Notice!**

Only amplifier channel 1 and the spare channel are capable of delivering up to 600 W maximum. All other channels are limited to 300 W maximum. In practice this does not impose any limitation on the flexibility of partitioning the total amplifier power across the channels, because if there is one zone with more than 300 W load, which is connected to channel 1, no other channel can be loaded with more than 300 W anymore without exceeding the total maximum of 600 W.

Three different loudspeaker connection topologies are supported, configurable in the system configuration:

**Single line A only**

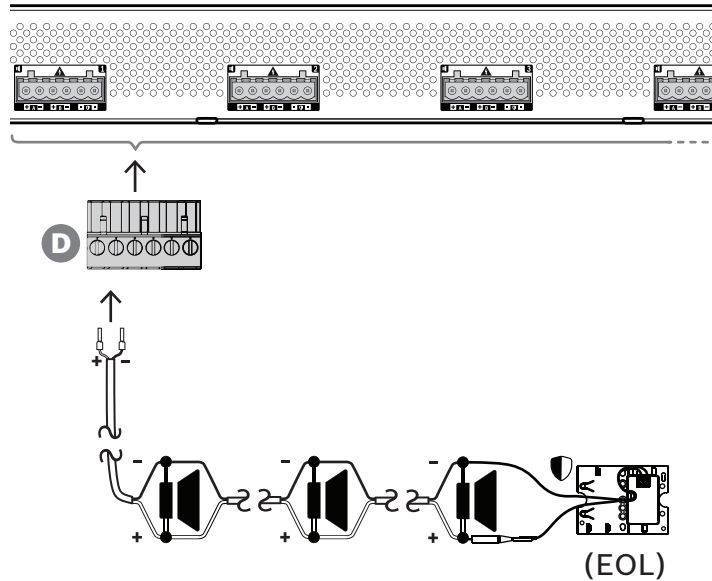

If no loudspeaker line redundancy is needed for a zone, then follow the procedure below to connect the loudspeakers to output A only:

1. Connect all loudspeakers in parallel, observing proper polarity. Select the right wire gauge, taking into account the connected loudspeaker power, the length of cable and the maximum permissible attenuation of the acoustic sound level due to loudspeaker line losses. See also section *Cable type recommendations*, page 30 for loudspeaker cable size recommendations.
2. Insert the near end wires of the loudspeaker cable into slots 1 and 2 of connector D, preferably using crimped on wire ferrules that fit to the wire gauge used. Observe polarity.
  - Use a flat blade screwdriver to tighten each connection.
3. If the connected loudspeakers are also intended for emergency sound and loudspeaker line supervision is required, make sure that all loudspeakers are connected in a loop-through fashion and that an end-of-line device is connected to the end of the loudspeaker line for supervision.
  - No cable spurs or branches are allowed, because they will not be supervised.

### Dual line (A + B)

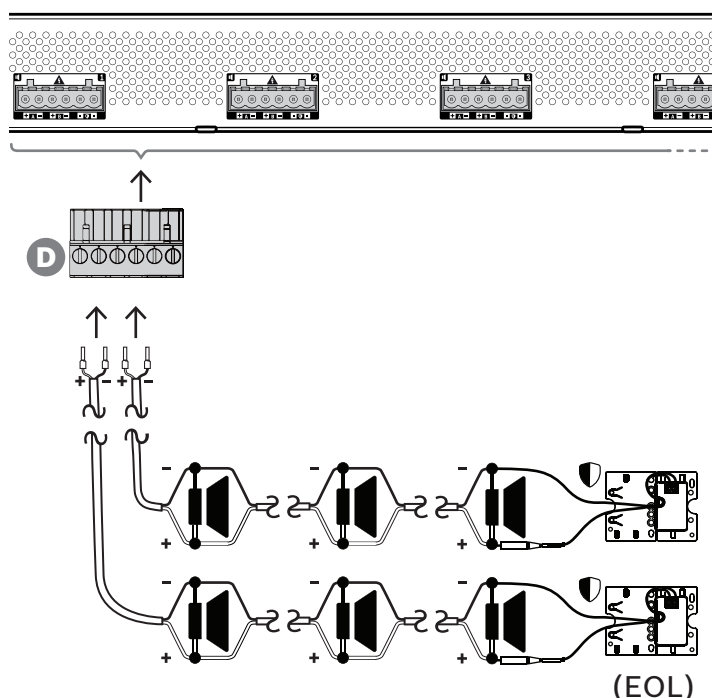

If loudspeaker line redundancy is needed, then follow the procedure below to connect two loudspeaker lines, one to output A and one to output B. Typically the loudspeakers are mounted alternating A, B, A, B, and so on, half the number connected to A, half the number connected to B.

When one loudspeaker line fails this may result in the loss of half the number of loudspeakers and with proper positioning of the loudspeakers the acoustic output level will drop by 3 dB SPL. A loudspeaker line fault will be reported.

1. Connect half of the loudspeakers in parallel in a loop-through fashion to output A. Observe polarity.
  - Follow the same wiring procedure as for using a single line.
2. Connect an end-of-line device to the end of loudspeaker line A.
3. Repeat this procedure for the other half of the loudspeakers and connect them to output B.
4. Connect an end-of-line device to the end of loudspeaker line B. Loudspeaker lines A and B must be separately supervised, each with its own end-of-line device. In case of a short circuit in one of the loudspeaker lines, the amplifier will diagnose the overload condition to find the affected loudspeaker line and switch-off that line, so the other loudspeaker line can continue operation.



**Loop (A to B)**

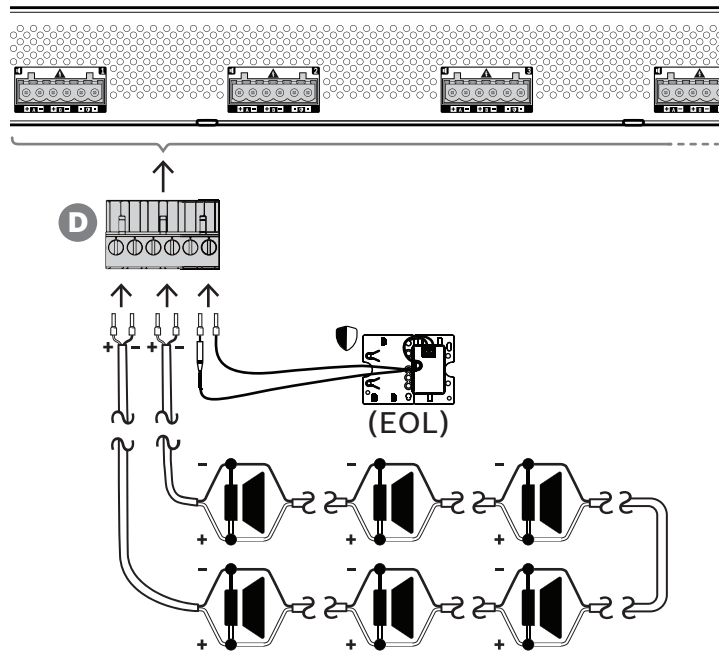

A third loudspeaker connection topology is the so-called Class-A loop, where the loudspeakers are connected in a loop, starting at output A and ending at output B, with the end of the loop being supervised with an end-of-line device.

In normal operation the loop is driven from output A only. In case of an interruption of the loudspeaker line, this will result in the loudspeaker signal not arriving at output B and neither at the end-of-line device. The disconnection of the end-of-line device will be detected at output A, and as a result output B will be activated to drive the loop from the opposite side in an attempt to reach all loudspeakers again. A loudspeaker line fault will be reported.

Follow the procedure below to connect the loudspeakers according to this scheme.

1. Connect all loudspeaker in parallel in a loop-through fashion. Observe equal polarity for all loudspeakers. Connect one side of the loudspeaker cable to output A, observing polarity.
2. Connect the other side of the loudspeaker cable to output B. In this case maintaining the correct polarity is especially important, as reversal on one end will short circuit the amplifier channel, not immediately, but when output B is activated in case of interruption of one conductor.
3. Connect an end-of-line device to the end-of-line connection terminals. These terminals are connected in parallel to output B, internally in the amplifier, to include supervision of the output B connection.

**Supervision**

The availability of the outputs A and B in fault conditions depends on the configured load connection of each amplifier channel (single line / dual line / loop) and on the configuration of the amplifier channel supervision and the loudspeaker line supervision.

Amplifier channel supervision (pilot tone)	Off	On	On
Loudspeaker line supervision (EOL)	Off	Off	On
Comment	Not for emergency sound	For use with the external line isolator system	For emergency sound
Single line (A only)	Outputs: A on, B off Pilot tone: off Spare channel: no	Outputs: A on, B off Pilot tone: on Spare channel: no	Outputs: A on, B off Pilot tone: on Spare channel: yes Output fault response: <ul style="list-style-type: none"> <li>- End-of-line fault on A: A on, B off</li> <li>- Short circuit fault on A: A and B off</li> </ul>
Dual line (A + B)	Not available	Not available	Outputs: A and B on Pilot tone: on Spare channel: yes Output fault response: <ul style="list-style-type: none"> <li>- End-of-line fault on A: A and B on</li> <li>- End-of-line fault on B: A and B on</li> <li>- Short circuit fault on A: A off, B on</li> <li>- Short circuit fault on B: A on, B off</li> </ul>
Loop (A to B)	Not available	Not available	Outputs: A on, B off Pilot tone: on Spare channel: yes Output fault response: <ul style="list-style-type: none"> <li>- End-of-line fault on B: A and B on</li> <li>- Short circuit fault on A: A and B off</li> </ul>

The supervision of the loudspeaker line always requires an end-of-line device at the end of each loudspeaker line. This detects an interrupted loudspeaker line, as well as short circuits away from the amplifier if there is no significant audio signal present.

If only the pilot tone is present:

- A short circuit close to the amplifier will decrease the voltage level of the pilot tone. This is detected as a short circuit.
- A short circuit further away from the amplifier will not decrease the voltage level of the pilot tone due to the low output impedance of the amplifier. In this case, no short circuit will be detected, but an end-of-line fault will be generated because the end-of-line device no longer receives a sufficiently high pilot tone to notify its presence.

If a significant audio signal is present:

- A short circuit in the loudspeaker line can cause the current to increase above the overcurrent threshold, depending on the resistance of the short circuit and the wiring. This activates the short circuit protection. The end-of-line device no longer receives a pilot tone to notify its presence. This combination is detected as a short circuit.

After detecting a fault in the loudspeaker line or load, the amplifier will try to localize and isolate the fault by activating the A and B outputs separately. This mechanism applies to all load connection options (single line / dual line / loop). In case of a loop connection, the loop will be driven from both sides when an end-of-line fault, but no short circuit, is detected. This counteracts an interruption of the loudspeaker line and keeps all loudspeakers active. It is not a remedy for short circuits in the loudspeaker line. Frequently, bad contacts are a source of intermittent loudspeaker line faults. In combination with the fault localization mechanism of the amplifier, this may lead to changing fault messages.

#### **Overheat protection**

Inside the amplifier, the temperature is measured on multiple locations to cover all amplifier channels.

When the temperature of one of the sensors rises above the first threshold, the fans go to full speed mode. In the UL-mode, the fans always run at full speed. When the measured temperature reaches the second threshold, the audio signal on all channels is attenuated with 3 dB to decrease the load and the heat generation. An **Overheat** fault with severity low is generated. The audio signals remain present, though at a slightly lower level.

The temperature should decrease. If the temperature continues to rise, the outside temperature is too high or the ventilation openings are blocked. In that case the amplifier channels mute and an **Overheat** fault with severity high is generated. When the temperature decreases, the high severity **Overheat** fault resets and the attenuated audio signals return. When the temperature continues to drop, the attenuation of the audio signals is lifted. The low severity **Overheat** fault resets. At an even lower temperature, the fans go back to the low speed mode to decrease the acoustical noise of the fans.

## 8.5.6

### Ethernet network

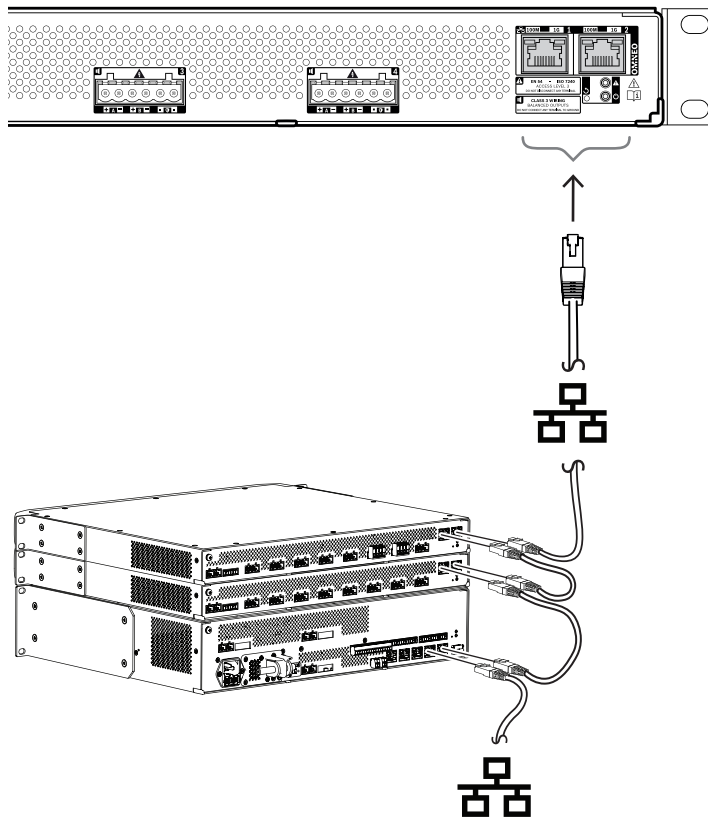

The amplifier has two Ethernet connection ports with a built-in Ethernet switch, supporting RSTP. Follow the procedure below to connect the amplifier to a network. The network must be set up in such a way that the amplifier can be discovered and reached by the system controller.

1. Use shielded Gb-Ethernet cables (preferably CAT6A F/UTP) with RJ45 connectors to connect the amplifier to the network.
2. Connect one end of the cable to one port of the amplifier.
3. Connect the other side of the cable to another network port in the network. This can be one port of the system controller, a port of a separate switch in the network, but also a port of another PRAESENSA device in the same rack.
4. The second port of the amplifier can be connected to a subsequent PRAESENSA device. The built-in Ethernet switch allows for a loopthrough interconnection between system devices, with a maximum of 21 devices in series.
5. For redundancy a looped through network connection may be connected at both sides to create a loop. RSTP must be enabled in the system.
6. For configuration, the amplifier is identified by its hostname, which is printed on the product label on the side of the device. The format of the hostname is the type number of the device without the dash, followed by a dash and then the last 6 hexadecimal digits of its MAC-address. Configuration is described in the PRAESENSA configuration manual.

## 8.5.7

### Reset to factory default

The reset switch resets the device to its factory default settings. This function is only to be used in case a secured device is removed from a system to become part of another system. See *Device status and reset*, page 71.

## 8.6

### Approvals

Emergency standard certifications	
Europe	EN 54-16 (0560-CPR-182190000)
International	ISO 7240-16
Maritime applications	DNV GL Type Approval
Mass Notifications Systems	UL 2572
Control Units and Accessories for Fire Alarm Systems	UL 864

Emergency standard compliance	
Europe	EN 50849
UK	BS 5839-8

Regulatory areas	
Safety	EN/IEC/CSA/UL 62368-1
Immunity	EN 55035 EN 50130-4
Emissions	EN 55032 EN 61000-6-3 ICES-003 FCC-47 part 15B class A EN 62479
Environment	EN/IEC 63000
Railway applications	EN 50121-4

## 8.7

### Technical data

#### Electrical

Loudspeaker load	
Maximum loudspeaker load 100 V mode, all channels* 70 V mode, all channels*	600 W 600 W
Minimum loudspeaker load impedance 100 V mode, all channels* 70 V mode, all channels*	16.7 ohm 8.3 ohm
Maximum cable capacitance 100 V mode, all channels* 70 V mode, all channels*	2 uF 2 uF
*All channels combined.	

<b>Amplifier outputs</b>	
Nominal output voltage 100 V mode, 1 kHz, THD <1%, no load 70 V mode, 1 kHz, THD <1%, no load	100 VRMS 70 VRMS
Nominal / rated power** All channels combined 100 V mode, load 16.7 ohm 70 V mode, load 8.3 ohm Channel 1 100 V mode, load 16.7 ohm // 20 nF 70 V mode, load 11.7 ohm // 20 nF Other channels 100 V mode, load 33.3 ohm // 20 nF 70 V mode, load 16.7 ohm // 20 nF	600 W / 150 W 600 W / 150 W 600 W / 150 W 420 W / 105 W 300 W / 75 W 300 W / 75 W
Full to no load regulation 20 Hz to 20 kHz	< 0.2 dB
Frequency response Rated power, +0.5 / -3 dB	20 Hz – 20 kHz
Total Harmonic Distortion + Noise (THD+N) Rated power, 20 Hz to 20 kHz 6 dB below rated power, 20 Hz to 20 kHz	< 0.5% < 0.1%
Intermodulation Distortion (ID) 6 dB below rated power, 19+20 kHz, 1:1	< 0.1%
Signal to Noise Ratio (SNR) 100 V mode, 20 Hz to 20 kHz 70 V mode, 20 Hz to 20 kHz	> 110 dBA typical > 107 dBA typical
Crosstalk between channels 100 Hz to 20 kHz	< -84 dBA
DC offset voltage	< 50 mV
Signal processing per channel Audio equalization Level control Level control resolution Audio delay Audio delay resolution RMS power limiter	7-section parametric 0 – -60 dB, mute 1 dB 0 – 60 s 1 ms Rated power
Lifeline Sensitivity (100 V out) Mute attenuation Signal to Noise Ratio (SNR)	0 dBV > 80 dB > 90 dBA
**Nominal power: EIAJ test standard, 1 kHz, 8/40 ms Rated power: RMS power, continuous	

<b>Power transfer</b>	
Power supply input A/B	
Input voltage	48 VDC
Input voltage tolerance	44 – 60 VDC
Power consumption (48 V)	
Sleep mode, no supervision	6.0 W
Snooze mode, supervision active	7.5 W
Active mode, idle	36 W
Active mode, low power	50 W
Active mode, rated power	222 W
Per active port	0.4 W
Heat loss (including power supply)	
Active mode, idle	166 kJ/h (157 BTU/h)
Active mode, low power	227 kJ/h (215 BTU/h)
Active mode, full power	339 kJ/h (321 BTU/h)
<b>Supervision</b>	
End-of-Line detection mode	Pilot tone 25.5 kHz, 3 VRMS
Power supply input A/B	Undervoltage
Ground short detection (loudspeaker lines)	< 50 kohm
Amplifier channel redundancy switching	Internal spare channel
Amplifier channel load	Short circuit
Loudspeaker line redundancy switching	A/B group, Class-A loop
Controller continuity	Watchdog
Temperature	Overheat
Fan	Rotation speed
Network interface	Link presence
<b>Network interface</b>	
Ethernet	100BASE-TX, 1000BASE-T
Protocol	TCP/IP
Redundancy	RSTP
Audio/control protocol	OMNEO
Network audio latency	10 ms
Audio data encryption	AES128
Control data security	TLS
Ports	2

<b>Reliability</b>	
MTBF (extrapolated from calculated MTBF of PRA-AD608)	300,000 h

**Environmental**

<b>Climatic conditions</b>	
Temperature	
Operating	-5 – 50 °C (23 – 122 °F)
Storage and transport	-30 – 70 °C (-22 – 158 °F)
Humidity (non-condensing)	5 – 95%
Air pressure (operating)	560 – 1070 hPa
Altitude (operating)	-500 – 5000 m (-1640 – 16404 ft)
Vibration (operating)	
Amplitude	< 0.7 mm
Acceleration	< 2 G
Bump (transport)	< 10 G (IEC 60068-2-27)

<b>Airflow</b>	
Fan airflow	Front to sides/rear
Fan noise	
Idle condition, 1 m distance	< 30 dBSPLA
Rated power, 1 m distance	< 53 dBSPLA

**Mechanical**

<b>Enclosure</b>	
Dimensions (HxWxD)	
With mounting brackets	44 x 483 x 400 mm (1.75 x 19 x 15.7 in)
Rack unit	19 in, 1U
Ingress protection	IP30
Case	
Material	Steel
Color	RAL9017
Frame	
Material	Zamak
Color	RAL9022HR
Weight	8.1 kg (17.9 lb)



## 9 Amplifier, 600W 8-channel (AD608)



### 9.1 Introduction

This is a flexible and compact multi-channel power amplifier for 100 V or 70 V loudspeaker systems in Public Address and Voice Alarm applications. It fits in centralized system topologies, but also supports decentralized system topologies because of its OMNEO IP-network connection, combined with DC-power from a multifunction power supply. The output power of each amplifier channel adapts to the connected loudspeaker load, only limited by the total power budget of the whole amplifier. This flexibility, and the integration of a spare amplifier channel, makes it possible to utilize the available power effectively and use less amplifiers for the same loudspeaker load, compared to using traditional amplifiers. Digital sound processing and control, adjusted to the acoustics and requirements of each zone, allow for better sound quality and speech intelligibility.

### 9.2 Functions

#### Efficient 8-channel power amplifier

- Transformerless, galvanically isolated, 70/100 V outputs for a maximum total loudspeaker load of 600 W.
- Cost and space saving, integrated, independent spare channel for fail-safe redundancy.
- Class D amplifier channels with two-level power lines for high-efficiency in all operating conditions; dissipation and heat loss is minimized to save on energy and battery capacity for backup power.
- Flexible partitioning of the available output power across all amplifier channels to use it effectively, significantly reducing the amount of required amplifier power in a system.

#### Flexibility in loudspeaker topologies

- A/B outputs on every amplifier channel to support redundant loudspeaker wiring topologies. Both outputs are individually supervised and disabled in case of a fault.
- Class A loop wiring possible between the A and B loudspeaker outputs.
- Load independent frequency response; the amplifier channels can be used with any loudspeaker load up to the maximum, without any change in audio quality.

#### Sound quality

- Audio-over-IP, using OMNEO, the Bosch high-quality digital audio interface, compatible with Dante and AES67; audio sample rate is 48 kHz with 24-bit sample size.
- Large signal to noise ratio, wide audio bandwidth and very low distortion and crosstalk.
- Digital signal processing on all amplifier channels, including equalization, limiting and delay, to optimize and tailor the sound in each loudspeaker zone.

#### Supervision

- Supervision of amplifier operation and all of its connections; faults are reported to the system controller and logged.
- Loudspeaker line integrity supervision without interruption of audio, using end-of-line devices (separately available) for best reliability.
- Network link supervision.

**Fault tolerance**

- Dual OMNEO network connections, supporting Rapid Spanning Tree Protocol (RSTP), for loop-through connections to adjacent devices.
- Dual 48 VDC inputs with polarity reversal protection, each with a full power DC/DC converter, operating in tandem for redundancy.
- Fully independent amplifier channels; the integrated spare channel automatically replaces a failing channel, with due regard of the actual sound processing settings.
- All amplifier channels support two independent loudspeaker groups, A and B, enabling redundant loudspeaker wiring topologies.
- Backup analog audio lifeline input driving the spare amplifier channel to serve all connected loudspeaker zones in case both network connections, or the amplifier network interface, would fail.

**9.3**

**Functional diagram**

**Functional and connection diagram**

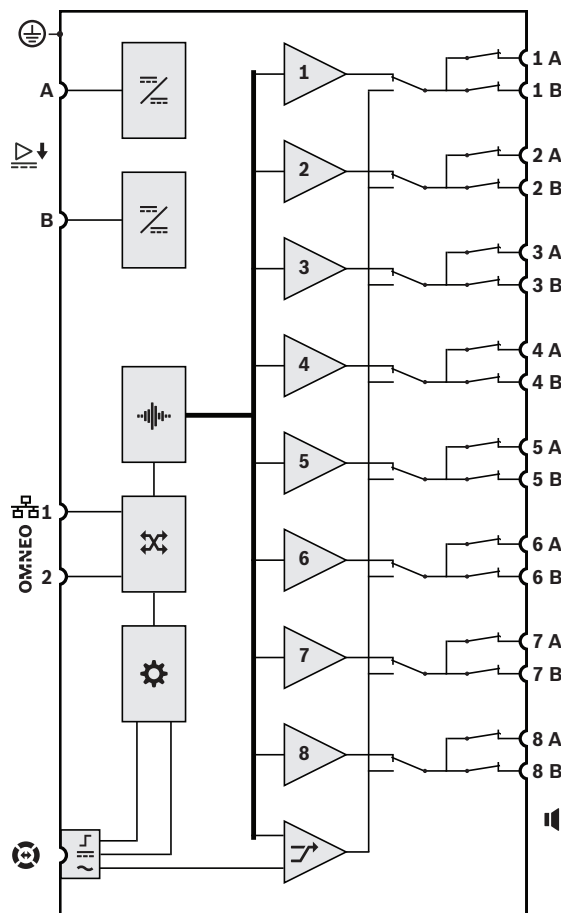

**Internal device functions**

- DC to DC converter
- Audio processing (DSP)
- OMNEO network switch
- Controller
- Lifeline control interface
- Lifeline supply input
- Lifeline audio input
- 1-8** Amplifier channel
- Spare channel

## 9.4 Indicators and connections



### Front panel indicators

	Spare channel substitute 1-8	White		Signal present 1-8 Fault present 1-8	Green Yellow
	Ground fault present	Yellow		Device fault present	Yellow
	Audio lifeline substitute	White		Network link to system controller present Network link lost Amplifier in standby mode	Green Yellow Blue
	Power on	Green		Identification mode / Indicator test	All LEDs blink

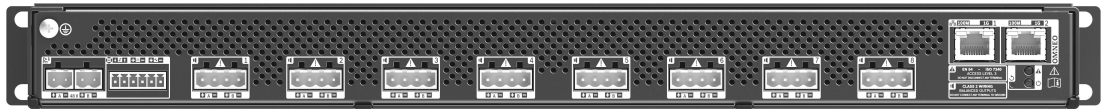

### Rear panel indicators and controls

	100 Mbps network 1 Gbps network	Yellow Green		Device fault present	Yellow
	Power on	Green		Device reset (to factory default)	Button
	Identification mode / Indicator test	All LEDs blink			

### Rear panel connections

	Safety ground			48 VDC input A-B	
	Lifeline interface			Loudspeaker output A-B (1-8)	
	Network port 1-2				

## 9.5 Installation

The device is designed to be installed in a 19"-rack/cabinet. Refer to: *Mounting the 19"-rack devices, page 27.*

The device can be connected everywhere within the PRAESENSA system. If required, refer to: *System introduction, page 19.*

### 9.5.1 Parts included

The box contains the following parts:

Quantity	Component
1	Amplifier, 600W 8-channel
1	Set of 19"-rack mounting brackets (pre-mounted)
1	Set of screw connectors and cables
1	Quick Installation Guide
1	Safety information

No tools or Ethernet cables are provided with the device.

#### Parts check and identification

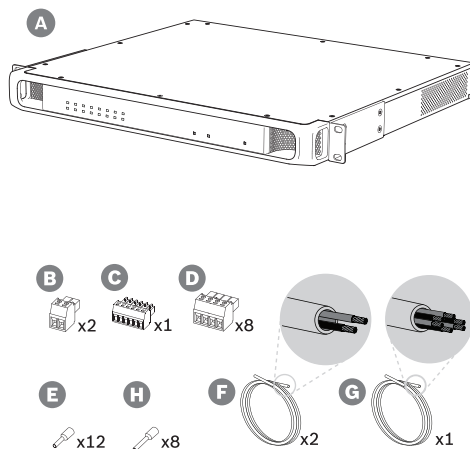

- A** Amplifier
- B** 2-pole screw plug (x2)
- C** 6-pole screw plug (small)
- D** 4-pole screw plug (large, x8)
- E** Wire-end ferrules (small, x12)
- F** 2-conductor cable (x2)
- G** 6-conductor cable
- H** Wire-end ferrules (large, x8)

## 9.5.2 Safety ground

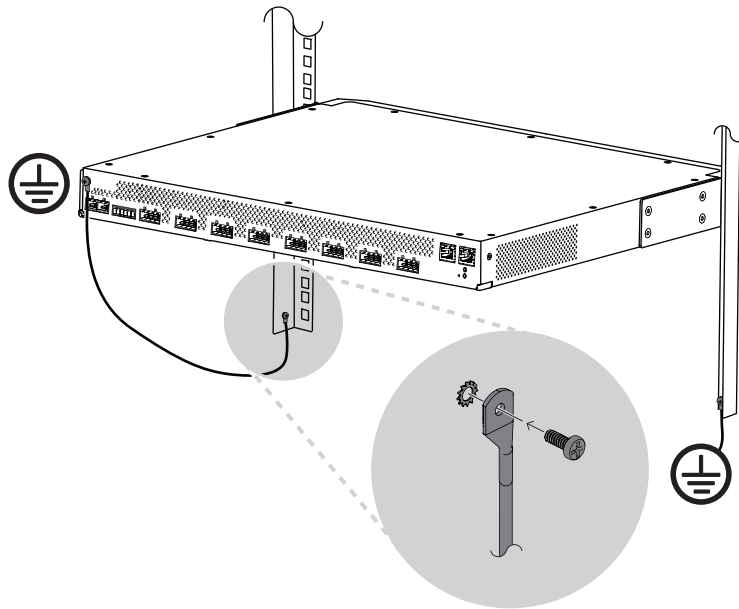

Connecting the chassis ground screw to safety ground is mandatory for the PRAESENSA power amplifiers:

- The safety ground connection is needed for safety because of high internal voltages. All PRAESENSA 19"-devices have a chassis ground screw on the rear panel, which can be used for a wire connection to the rack frame. The rack frame must be grounded to safety ground. This is a conductive path to ground or earth that is designed to protect persons from electrical shock by shunting away any dangerous currents that might occur due to malfunction or accident. Use a thick, multi strand wire ( $>2.5 \text{ mm}^2$ ) with wire eyelets and washers for a solid connection.
- The safety ground connection is needed as reference for the ground short detection circuit. Without this connection, the amplifier could be electrically floating and no ground shorts or leakage currents would be detected for loudspeaker lines that touch ground somewhere. The safety ground connection via the mains connection of the multifunction power supply cannot be relied on for this, because the mains cable of this supply could be unplugged and then the amplifier continues to work on the backup battery.



### Caution!

The chassis ground screw of an amplifier must be connected to protective ground **before** the amplifier is connected to a power supply.

## 9.5.3 Power supply

The amplifier must be powered from a 48 V power supply. If the amplifier is used as part of a certified emergency sound system, it must be powered from a PRAESENSA multifunction power supply. In case the amplifier and the power supply are mounted in two different racks, double power supply connections must be made, but even if both devices are in the same rack, it is recommended to use double connections for fail-safe redundancy.

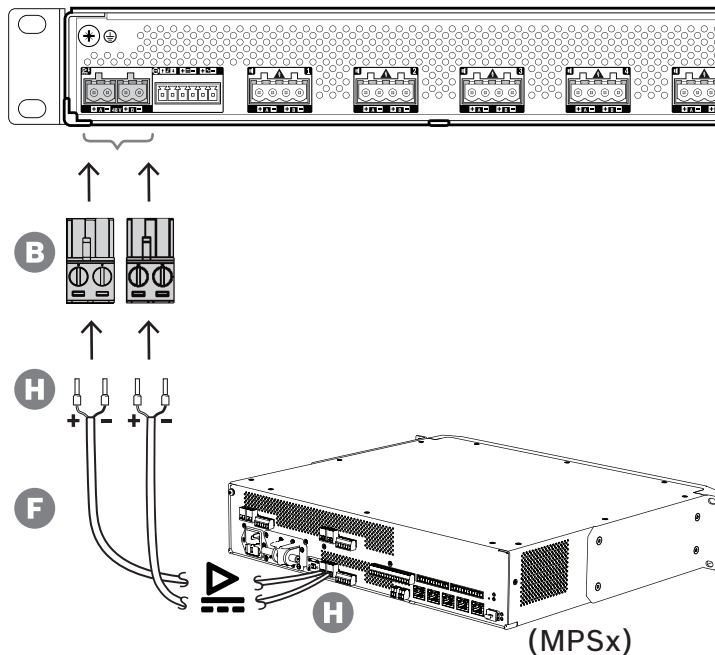

Follow the connection procedure below:

1. Crimp ferrules H onto the ends of the electrical wires of cable F to provide a solid and reliable electrical connection.
  - Use a dedicated crimping tool.
2. Insert each wire into the appropriate slot of the connector B, observing polarity. Wiring color convention: red for + and black for -.
  - Use a flat blade screwdriver to tighten each connection.
3. Insert the cable into the 48 V input A, cut the cable to length and mount the connector of the powering device to the other end of the cable, again observing polarity. Insert this connector into output A of the powering device.
4. For redundancy, repeat these steps for a second cable between output B of the powering device to input B of the amplifier.
5. Alternatives:
  - Instead of using the A/B outputs of a PRAESENSA powering device, also two separate power supplies can be used. The maximum current rating of the supply connectors is 15 A; only use a 48 V power supply that is current limited to < 15 A, also in overload condition.
  - When no power supply redundancy is required, a single power supply can be used; in that case connect the 48 V inputs A and B in parallel to make use of the amplifier's internal dual power converters for fail safe redundancy and to avoid a supply supervision fault event.

## 9.5.4

### Lifeline

The lifeline is an optional cable connection between a PRAESENSA amplifier and a PRAESENSA multifunction power supply. This interconnection serves multiple functions:

- The multifunction power supply provides the audio signal of the highest priority emergency call as a balanced line level analog signal on the lifeline connector (pins 5 and 6). This signal is a backup audio signal for the connected amplifier in case its network interface or both network links would fail. The emergency call will then be

- distributed to all connected loudspeakers at maximum volume and without equalization or audio delay. The lifeline signal goes straight to the spare amplifier channel to drive all zones in parallel. This line is supervised by the multifunction power supply.
- The multifunction power supply sends information (pin 1) to the connected amplifier about the availability of mains power. In case mains power fails and power is provided from the battery, this signal sets the amplifier in backup power mode to disable all amplifier channels that are not needed to make calls with a priority above the configured priority level for the backup power mode. When no high priority calls are being made via this amplifier, it informs the multifunction power supply (pin 2) to switch off the 48 V converters to minimize battery power consumption even more. The power supplies and the amplifier channels go to snooze mode and wake up every 90 seconds briefly to perform the required supervision actions for timely fault reporting.
  - The multifunction power supply provides the battery or charger voltage, in the range of 12 to 18 V, to the amplifier directly (pins 3 and 4) to supply power to the amplifier's network interface while the 48 V power supplies are switched off.



### Notice!

When the amplifier is powered from one or two normal 48 V power supplies, that do not have a lifeline interface, the power saving and audio bypass functions are not available. All other amplifier functions are still available.

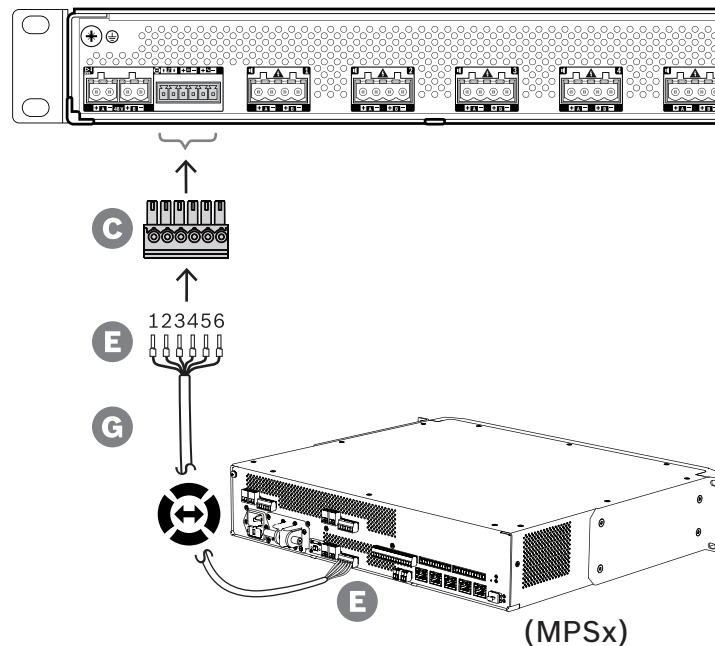

To create a lifeline connection, follow the procedure below.

1. Crimp ferrules E onto the ends of the electrical wires of cable G to provide a solid and reliable electrical connection.
  - Use a dedicated crimping tool.
2. Insert each wire into the appropriate slot of the connector C. The wiring order is not critical, but use the same order for all lifeline cables in the system to minimize the risk of errors.
  - Use a flat blade screwdriver to tighten each connection.

3. Insert the cable connector into the amplifier's lifeline socket, cut the cable to length and mount a connector of the same type, delivered with the multifunction power supply to the other end of the cable, observing wiring order. Insert this connector into the lifeline socket of the multifunction power supply.

**Notice!**

The lifeline connection may not be longer than 3 m.

**9.5.5****Amplifier outputs**

The amplifier provides eight output channels and a spare channel that substitutes a failing channel.

The channels have direct drive 70/100 V outputs for low distortion, low crosstalk and a wide audio bandwidth. There are no output transformers that would be a limiting factor for the output power of each channel. Every channel also has a load independent flat frequency response. This combination of features makes it possible to partition the available amplifier power across all channels and utilize that power effectively.

Every channel has a 4-pole connector socket, providing independently switched loudspeaker group A and group B outputs. It supports three different loudspeaker connection topologies, configurable in the system configuration:

**Caution!**

For compliance to UL 62368-1 and CAN/CSA C22.2 No. 62368-1 all loudspeaker wiring must be Class 2 wiring (CL2); this requirement does not apply for compliance to EN/IEC 62368-1.

**Caution!**

Amplifier outputs may carry output voltages up to 100 VRMS. Touching uninsulated terminals or wiring may result in an unpleasant sensation.

**Notice!**

Only amplifier channel 1 and the spare channel are capable of delivering up to 600 W maximum. All other channels are limited to 300 W maximum. In practice this does not impose any limitation on the flexibility of partitioning the total amplifier power across the channels, because if there is one zone with more than 300 W load, which is connected to channel 1, no other channel can be loaded with more than 300 W anymore without exceeding the total maximum of 600 W.



Three different loudspeaker connection topologies are supported, configurable in the system configuration:

### Single line A only

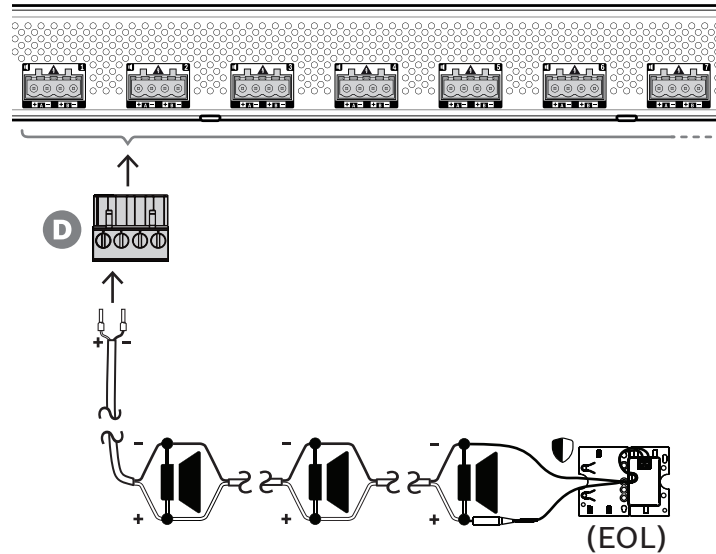

If no loudspeaker line redundancy is needed for a zone, then follow the procedure below to connect the loudspeakers to output A only:

1. Connect all loudspeakers in parallel, observing proper polarity. Select the right wire gauge, taking into account the connected loudspeaker power, the length of cable and the maximum permissible attenuation of the acoustic sound level due to loudspeaker line losses. See also section *Cable type recommendations*, page 30 for loudspeaker cable size recommendations.
2. Insert the near end wires of the loudspeaker cable into slots 1 and 2 of connector D, preferably using crimped on wire ferrules that fit to the wire gauge used. Observe polarity.
  - Use a flat blade screwdriver to tighten each connection.
3. If the connected loudspeakers are also intended for emergency sound and loudspeaker line supervision is required, make sure that all loudspeakers are connected in a loop-through fashion and that an end-of-line device is connected to the end of the loudspeaker line for supervision.
  - No cable spurs or branches are allowed, because they will not be supervised.

### Dual line (A + B)

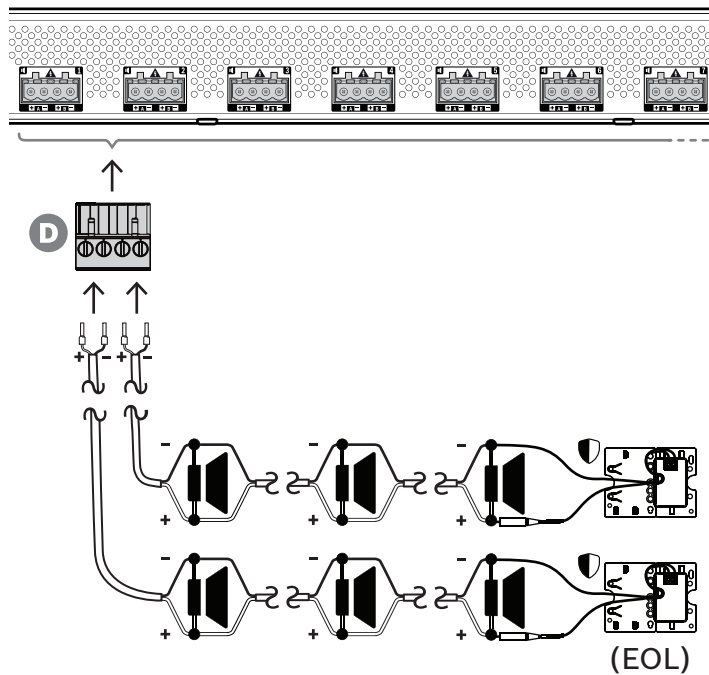

If loudspeaker line redundancy is needed, then follow the procedure below to connect two loudspeaker lines, one to output A and one to output B. Typically the loudspeakers are mounted alternating A, B, A, B, and so on, half the number connected to A, half the number connected to B.

When one loudspeaker line fails this may result in the loss of half the number of loudspeakers and with proper positioning of the loudspeakers the acoustic output level will drop by 3 dB SPL. A loudspeaker line fault will be reported.

1. Connect half of the loudspeakers in parallel in a loop-through fashion to output A. Observe polarity.
  - Follow the same wiring procedure as for using a single line.
2. Connect an end-of-line device to the end of loudspeaker line A.
3. Repeat this procedure for the other half of the loudspeakers and connect them to output B.
4. Connect an end-of-line device to the end of loudspeaker line B. Loudspeaker lines A and B must be separately supervised, each with its own end-of-line device. In case of a short circuit in one of the loudspeaker lines, the amplifier will diagnose the overload condition to find the affected loudspeaker line and switch-off that line, so the other loudspeaker line can continue operation.

### Loop (A to B)

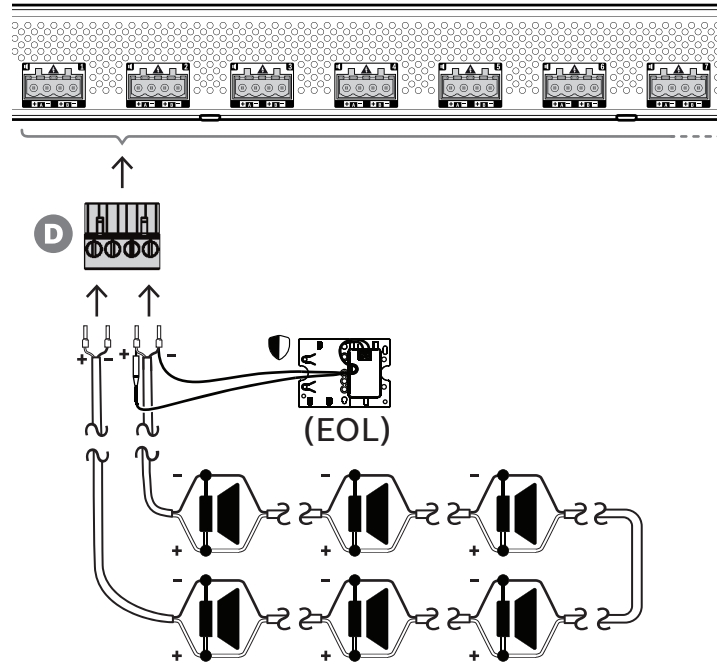

A third loudspeaker connection topology is the so-called Class-A loop, where the loudspeakers are connected in a loop, starting at output A and ending at output B, with the end of the loop being supervised with an end-of-line device.

In normal operation the loop is driven from output A only. In case of an interruption of the loudspeaker line, this will result in the loudspeaker signal not arriving at output B and neither at the end-of-line device. The disconnection of the end-of-line device will be detected at output A, and as a result output B will be activated to drive the loop from the opposite side in an attempt to reach all loudspeakers again. A loudspeaker line fault will be reported.

Follow the procedure below to connect the loudspeakers according to this scheme:

1. Connect all loudspeaker in parallel in a loop-through fashion. Observe equal polarity for all loudspeakers. Connect one side of the loudspeaker cable to output A, observing polarity.
2. Connect the other side of the loudspeaker cable to output B. In this case maintaining the correct polarity is especially important, as reversal on one end will short circuit the amplifier channel, not immediately, but when output B is activated in case of interruption of one conductor.
3. Connect an end-of-line device to output B, in parallel with the loudspeaker cable.



### Notice!

Unlike the 4-channel amplifier, the outputs of the 8-channel amplifier use 4-pole connectors without separate terminals for the end-of-line device.

Do not replace the 4-pole plug by two 2-pole plugs for outputs A and B separately, because then it is possible that plug B gets disconnected from the amplifier, while the end-of-line device remains connected to the loudspeaker line and no fault is being reported, until an interruption occurs in the loop. Only then it will appear that the loudspeaker line after the interruption cannot be driven from output B anymore. When the 4-pole plug for outputs A and B combined would get unplugged unintentionally, then both outputs A and B would be disconnected together with the end-of-line device and a fault would be reported immediately.

### Supervision

The availability of the outputs A and B in fault conditions depends on the configured load connection of each amplifier channel (single line / dual line / loop) and on the configuration of the amplifier channel supervision and the loudspeaker line supervision.

Amplifier channel supervision (pilot tone)	Off	On	On
Loudspeaker line supervision (EOL)	Off	Off	On
Comment	Not for emergency sound	For use with the external line isolator system	For emergency sound
Single line (A only)	Outputs: A on, B off Pilot tone: off Spare channel: no	Outputs: A on, B off Pilot tone: on Spare channel: no	Outputs: A on, B off Pilot tone: on Spare channel: yes Output fault response: – End-of-line fault on A: A on, B off – Short circuit fault on A: A and B off
Dual line (A + B)	Not available	Not available	Outputs: A and B on Pilot tone: on Spare channel: yes Output fault response: – End-of-line fault on A: A and B on – End-of-line fault on B: A and B on – Short circuit fault on A: A off, B on

			<ul style="list-style-type: none"> <li>- Short circuit fault on B: A on, B off</li> </ul>
Loop (A to B)	Not available	Not available	Outputs: A on, B off Pilot tone: on Spare channel: yes Output fault response: <ul style="list-style-type: none"> <li>- End-of-line fault on B: A and B on</li> <li>- Short circuit fault on A: A and B off</li> </ul>

The supervision of the loudspeaker line always requires an end-of-line device at the end of each loudspeaker line. This detects an interrupted loudspeaker line, as well as short circuits away from the amplifier if there is no significant audio signal present.

If only the pilot tone is present:

- A short circuit close to the amplifier will decrease the voltage level of the pilot tone. This is detected as a short circuit.
- A short circuit further away from the amplifier will not decrease the voltage level of the pilot tone due to the low output impedance of the amplifier. In this case, no short circuit will be detected, but an end-of-line fault will be generated because the end-of-line device no longer receives a sufficiently high pilot tone to notify its presence.

If a significant audio signal is present:

- A short circuit in the loudspeaker line can cause the current to increase above the overcurrent threshold, depending on the resistance of the short circuit and the wiring. This activates the short circuit protection. The end-of-line device no longer receives a pilot tone to notify its presence. This combination is detected as a short circuit.

After detecting a fault in the loudspeaker line or load, the amplifier will try to localize and isolate the fault by activating the A and B outputs separately. This mechanism applies to all load connection options (single line / dual line / loop). In case of a loop connection, the loop will be driven from both sides when an end-of-line fault, but no short circuit, is detected. This counteracts an interruption of the loudspeaker line and keeps all loudspeakers active. It is not a remedy for short circuits in the loudspeaker line. Frequently, bad contacts are a source of intermittent loudspeaker line faults. In combination with the fault localization mechanism of the amplifier, this may lead to changing fault messages.

**Overheat protection**

Inside the amplifier, the temperature is measured on multiple locations to cover all amplifier channels.

When the temperature of one of the sensors rises above the first threshold, the fans go to full speed mode. In the UL-mode, the fans always run at full speed. When the measured temperature reaches the second threshold, the audio signal on all channels is attenuated with 3 dB to decrease the load and the heat generation. An **Overheat** fault with severity low is generated. The audio signals remain present, though at a slightly lower level.

The temperature should decrease. If the temperature continues to rise, the outside temperature is too high or the ventilation openings are blocked. In that case the amplifier channels mute and an **Overheat** fault with severity high is generated. When the temperature decreases, the high severity **Overheat** fault resets and the attenuated audio signals return. When the temperature continues to drop, the attenuation of the audio signals is lifted. The low severity **Overheat** fault resets. At an even lower temperature, the fans go back to the low speed mode to decrease the acoustical noise of the fans.

## 9.5.6

### Ethernet network

The amplifier has two Ethernet connection ports with a built-in Ethernet switch, supporting RSTP. Follow the procedure below to connect the amplifier to a network. The network must be set up in such a way that the amplifier can be discovered and reached by the system controller.

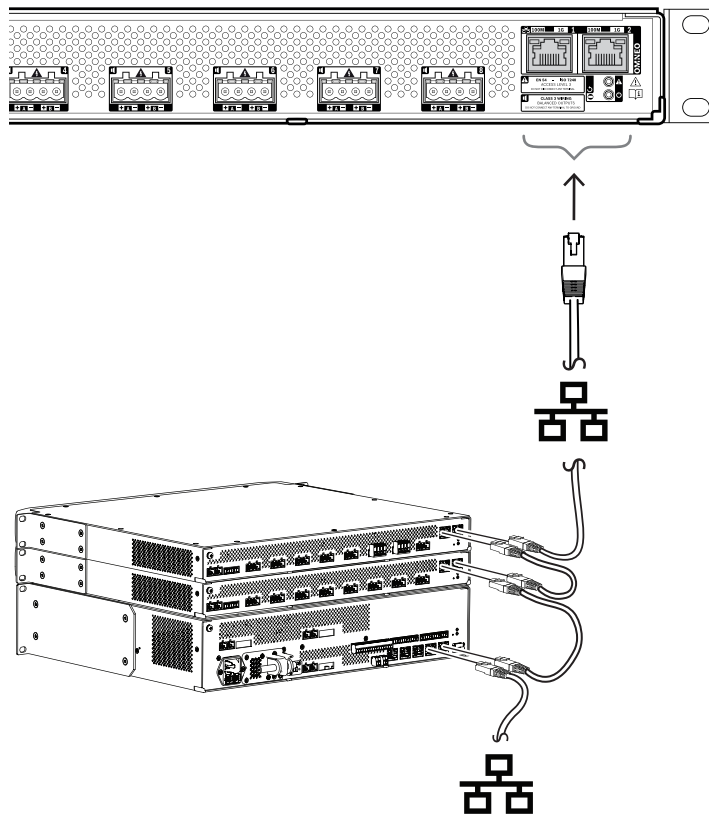

1. Use shielded Gb-Ethernet cables (preferably CAT6A F/UTP) with RJ45 connectors to connect the amplifier to the network.
2. Connect one end of the cable to one port of the amplifier.
3. Connect the other side of the cable to another network port in the network. This can be one port of the system controller, a port of a separate switch in the network, but also a port of another PRAESENSA device in the same rack.
4. The second port of the amplifier can be connected to a subsequent PRAESENSA device. The built-in Ethernet switch allows for a loopthrough interconnection between system devices, with a maximum of 21 devices in series.
5. For redundancy a looped through network connection may be connected at both sides to create a loop. RSTP must be enabled in the system.

- 6. For configuration, the amplifier is identified by its hostname, which is printed on the product label on the side of the device. The format of the hostname is the type number of the device without the dash, followed by a dash and then the last 6 hexadecimal digits of its MAC-address. Configuration is described in the PRAESENSA configuration manual.

**9.5.7 Reset to factory default**

The reset switch resets the device to its factory default settings. This function is only to be used in case a secured device is removed from a system to become part of another system. See *Device status and reset*, page 71.

**9.6 Approvals**

Emergency standard certifications	
Europe	EN 54-16 (0560-CPR-182190000)
International	ISO 7240-16
Maritime applications	DNV GL Type Approval
Mass Notifications Systems	UL 2572
Control Units and Accessories for Fire Alarm Systems	UL 864

Emergency standard compliance	
Europe	EN 50849
UK	BS 5839-8

Regulatory areas	
Safety	EN/IEC/CSA/UL 62368-1
Immunity	EN 55035 EN 50130-4
Emissions	EN 55032 EN 61000-6-3 ICES-003 FCC-47 part 15B class A EN 62479
Environment	EN/IEC 63000
Railway applications	EN 50121-4

**9.7 Technical data**

**Electrical**

Loudspeaker load	
Maximum loudspeaker load 100 V mode, all channels*	600 W
70 V mode, all channels*	600 W

<b>Loudspeaker load</b>	
Minimum loudspeaker load impedance 100 V mode, all channels* 70 V mode, all channels*	16.7 ohm 8.3 ohm
Maximum cable capacitance 100 V mode, all channels* 70 V mode, all channels*	2 uF 2 uF
*All channels combined.	

<b>Amplifier outputs</b>	
Nominal output voltage 100 V mode, 1 kHz, THD <1%, no load 70 V mode, 1 kHz, THD <1%, no load	100 VRMS 70 VRMS
Nominal / rated power** All channels combined 100 V mode, load 16.7 ohm 70 V mode, load 8.3 ohm Channel 1 100 V mode, load 16.7 ohm // 20 nF 70 V mode, load 11.7 ohm // 20 nF Other channels 100 V mode, load 33.3 ohm // 20 nF 70 V mode, load 16.7 ohm // 20 nF	600 W / 150 W 600 W / 150 W 600 W / 150 W 420 W / 105 W 300 W / 75 W 300 W / 75 W
Full to no load regulation 20 Hz to 20 kHz	< 0.2 dB
Frequency response Rated power, +0.5 / -3 dB	20 Hz – 20 kHz
Total Harmonic Distortion + Noise (THD+N) Rated power, 20 Hz to 20 kHz 6 dB below rated power, 20 Hz to 20 kHz	< 0.5% < 0.1%
Intermodulation Distortion (ID) 6 dB below rated power, 19+20 kHz, 1:1	< 0.1%
Signal to Noise Ratio (SNR) 100 V mode, 20 Hz to 20 kHz 70 V mode, 20 Hz to 20 kHz	> 110 dBA typical > 107 dBA typical
Crosstalk between channels 100 Hz to 20 kHz	< -84 dBA
DC offset voltage	< 50 mV
Signal processing per channel Audio equalization Level control Level control resolution	7-section parametric 0 – -60 dB, mute 1 dB



<b>Amplifier outputs</b>	
Audio delay	0 – 60 s
Audio delay resolution	1 ms
RMS power limiter	Rated power
Lifeline	
Sensitivity (100 V out)	0 dBV
Mute attenuation	> 80 dB
Signal to Noise Ratio (SNR)	> 90 dBA
**Nominal power: EIAJ test standard, 1 kHz, 8/40 ms	
Rated power: RMS power, continuous	

<b>Power transfer</b>	
Power supply input A/B	
Input voltage	48 VDC
Input voltage tolerance	44 – 60 VDC
Power consumption (48 V)	
Sleep mode, no supervision	6.0 W
Snooze mode, supervision active	8.9 W
Active mode, idle	56 W
Active mode, low power	77 W
Active mode, rated power	246 W
Per active port	0.4 W
Heat loss (including power supply)	
Active mode, idle	237 kJ/h (225 BTU/h)
Active mode, low power	325 kJ/h (308 BTU/h)
Active mode, full power	434 kJ/h (412 BTU/h)

<b>Supervision</b>	
End-of-Line detection mode	Pilot tone 25.5 kHz, 3 VRMS
Power supply input A/B	Undervoltage
Ground short detection (loudspeaker lines)	< 50 kohm
Amplifier channel redundancy switching	Internal spare channel
Amplifier channel load	Short circuit
Loudspeaker line redundancy switching	A/B group, Class-A loop
Controller continuity	Watchdog
Temperature	Overheat
Fan	Rotation speed
Network interface	Link presence

<b>Network interface</b>	
Ethernet	100BASE-TX, 1000BASE-T
Protocol	TCP/IP
Redundancy	RSTP
Audio/control protocol	OMNEO
Network audio latency	10 ms
Audio data encryption	AES128
Control data security	TLS
Ports	2
<b>Reliability</b>	
MTBF (calculated according to Telcordia SR-332 Issue 3)	250,000 h
<b>Environmental</b>	
<b>Climatic conditions</b>	
Temperature	
Operating	-5 – 50 °C (23 – 122 °F)
Storage and transport	-30 – 70 °C (-22 – 158 °F)
Humidity (non-condensing)	5 – 95%
Air pressure (operating)	560 – 1070 hPa
Altitude (operating)	-500 – 5000 m (-1640 – 16404 ft)
Vibration (operating)	
Amplitude	< 0.7 mm
Acceleration	< 2 G
Bump (transport)	< 10 G (IEC 60068-2-27)
<b>Airflow</b>	
Fan airflow	Front to sides/rear
Fan noise	
Idle condition, 1 m distance	< 30 dBSPLA
Rated power, 1 m distance	< 53 dBSPLA
<b>Mechanical</b>	
<b>Enclosure</b>	
Dimensions (HxWxD)	
With mounting brackets	44 x 483 x 400 mm (1.75 x 19 x 15.7 in)
Rack unit	19 in, 1U

<b>Enclosure</b>	
Ingress protection	IP30
Case Material Color	Steel RAL9017
Frame Material Color	Zamak RAL9022HR
Weight	8.8 kg (19.4 lb)

## 10 End-of-line device (EOL)



### 10.1 Introduction

This end-of-line device is a reliable solution for loudspeaker line integrity supervision, which is a requirement for emergency sound systems.

It is connected at the end of a loudspeaker line, after the last loudspeaker of a series of looped-through loudspeakers.

It communicates with the PRAESENSA amplifier channel driving that loudspeaker line, to confirm the integrity of the line.

Where impedance measurements may not detect a disconnected loudspeaker, depending on the number of connected loudspeakers and cable type, or report false faults, the end-of-line device provides a superior solution to report the correct status of the loudspeaker line.

The enclosure size is compatible with the mounting provisions in most Bosch loudspeakers for supervision boards or devices. It can also be reduced in size to fit most cable junction boxes.

### 10.2 Product variant PRA-EOL-US

The PRA-EOL-US device is identical to the PRA-EOL , but comes without the set of connection wires and thermal fuse. This variant is certified for UL 2572 and UL 864 for USA and Canada. The wiring and mounting instructions of the PRA-EOL apply to the PRA-EOL-US, but the connection wires must be no smaller than 18 AWG (0.82 mm<sup>2</sup>) without thermal fuse. A mounting screw and washer are included to mount this device in a metal junction box.

### 10.3 Functions

#### Supervision

- Reliable supervision of a single loudspeaker line, using loudspeakers connected in a loop-through fashion.
- Operation is based on pilot tone detection from the amplifier with feedback to the amplifier using the loudspeaker line itself. No additional wiring is needed for fault or status reporting.
- The A/B outputs of a PRAESENSA amplifier channel are supervised individually, with separate end-of-line devices.
- To reduce power consumption, PRAESENSA amplifier channels use pilot tone modulation.
- The audibility of the pilot tone is virtually eliminated by using a pilot tone amplitude of only 3 VRMS with a frequency of 25.5 kHz, amply outside the human hearing range, even for young children.

#### Mounting

- The PRAESENSA end-of-line device is small, lightweight and fits to the mounting provisions in most Bosch loudspeakers for supervision boards (board shape). It comes with push terminal connected flying leads, containing a thermal fuse, for easy connection to the last loudspeaker of a loudspeaker line.



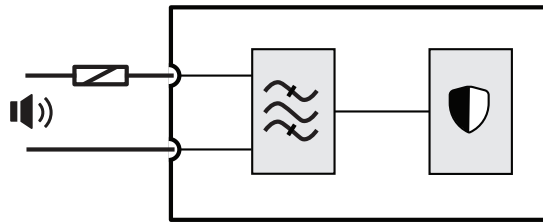

- Part of the mounting plate of the device can be broken off and snapped in place as bottom plate, making the device enclosure IP30 compliant, for use outside a loudspeaker enclosure (box shape). The enclosure contains a wiring strain relief for additional protection.
- Various mounting holes in the enclosure allow for mounting the device in most standard cable junction boxes. In this case the loudspeaker line enters the box via a standard cable gland and is connected using the push terminal.

## 10.4 Functional diagram

Functional and connection diagram



Internal device functions

-  Thermal fuse
-  Loudspeaker line
-  Bandpass filter
-  Supervision receiver/transmitter

## 10.5 Connections



Device connections

	Loudspeaker line	
---	------------------	---

## 10.6 Installation

### 10.6.1 Parts included

The box contains the following parts:

Quantity	Component
1	End of line device
1	Set of connection wires with thermal fuse
1 per box	Quick Installation Guide
1 per box	Safety information

No tools are provided with the device.

### Parts check and identification

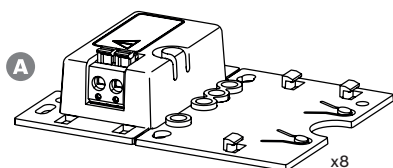

- A** End-of-line device
- B** Connection wires with thermal fuse



## 10.6.2

### Wiring

The end-of-line device must be connected to the end of a loudspeaker line, to monitor the full length of the line. All loudspeakers connected to that line must be wired in a loop-through arrangement, without branches. The end-of-line device is then connected to the last loudspeaker using the supplied connection wire.

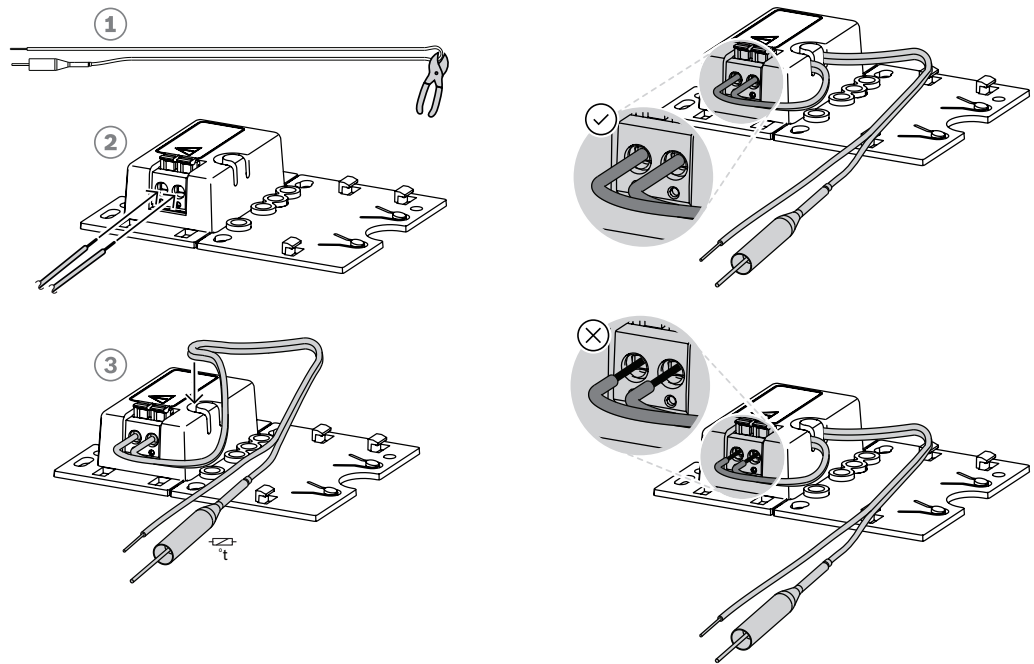

To do so:

1. Cut (1) the supplied connection wire with the thermal fuse in two halves.
2. Connect the two wires to the 100 V or 70 V loop-through connection of the loudspeaker, with the thermal fuse at the loudspeaker side:
  - This is the primary side of the loudspeaker transformer.
  - The polarity is not important for the end-of-line device, but it is good practice to connect the wire with the thermal fuse to the positive loudspeaker terminal.
  - The thermal fuse is to disconnect the end-of-line device and its wires from the loudspeaker line in case of fire. This prevents that the loudspeaker line might be shorted in case the wire insulation melts.
3. Cut the wires (2) to the required length for connection to the end-of-line device, feeding the wires through the strain relief slot (3) in the plastic housing:
  - The end-of-line device uses a 2-pole push wire connector.
  - The stripped wire ends must be inserted into the connector completely, up to the insulation, to prevent that the wires can be touched.

**Notice!**

For the PRA-EOL device, the maximum cable capacitance for reliable supervision is 80 nF. You can measure the cable capacitance when it is not clearly specified by the cable manufacturer.

For both a shielded and an unshielded cable, the cable capacitance is measured with an LCR-meter between the two conductors. Measure a known length of the cable, for instance 10 m, and calculate the capacitance of the total length to be installed. The capacitance scales with the length of the cable in a linear manner. For a shielded cable, this measurement automatically includes the effect of the shield.

The capacitance of a symmetrical, shielded cable with two conductors is always higher than the capacitance of the same cable without shield. The capacitance of a shielded cable is the sum of two parts: (1) the capacitance between the two conductors, and (2) half of the capacitance of each conductor to the shield. An unshielded cable only has the capacitance of part (1).

Avoid the use of shielded cables. The higher capacitance of shielded cables results in an increased amplifier load.

**Notice!**

The prolonged high-level, high-frequency content of audio signals can mask the pilot tone detection and feedback. This can cause false positive line supervision faults. This does not happen for business calls, background music, and attention and alarm tones, because of the spectral content of these signals and of the variance of the signal. However, be careful with test tones. For more information, refer to *Resilience of EOL-supervision for high frequency tones*, page 289.

**Notice!**

When you replace an existing voice alarm system by PRAESENSA and reuse the loudspeaker lines and loudspeakers, remove all end-of-line devices and loudspeaker supervision devices that were part of the previous system. Their presence can interfere with the operation of the PRAESENSA end-of-line devices.





### 10.6.3

## Mounting

Most Bosch loudspeakers have a provision to mount the end-of-line device as a flat panel using the holes in the mounting plate.



### Caution!

When PRA-EOL devices are mounted at a height above 2 m from the ground, special care should be taken to avoid that a device falls and may hurt a person.



### Caution!

For compliance to NFPA 70 and CSA C22.1, the device must be mounted in a junction box.

Part of the mounting plate of the end-of-line device can be broken off (1) and snapped in place as bottom plate (2+3). Then the device can be mounted outside the loudspeaker cabinet or inside a cable junction box.

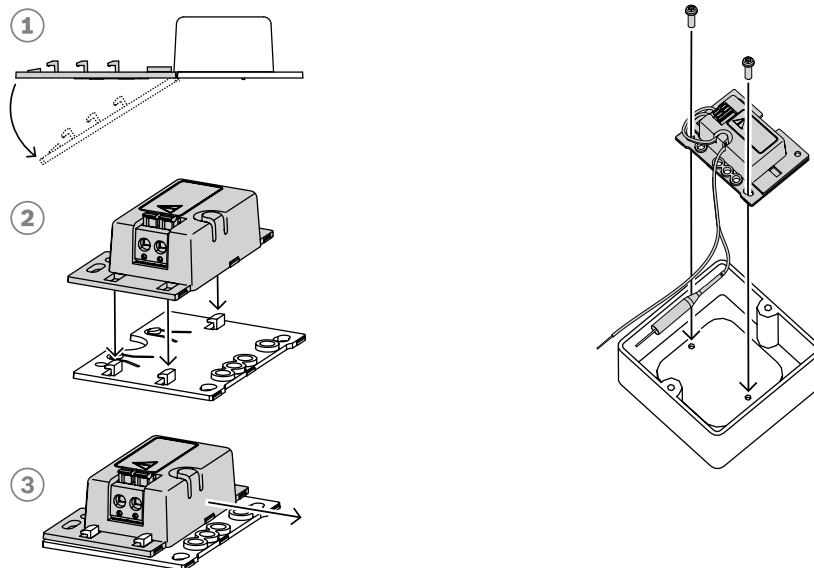

### Notice!

When selecting cables and wire gauge for loudspeaker connections, take into account the length and loudspeaker load to avoid excessive power loss. Make sure that the signal level at the end of the loudspeaker line has not dropped with more than 2 dB (this is approximately 20%), as this will also affect proper operation of the end-of-line device. Also see section *Cable type recommendations*, page 30.



### Notice!

The PRA-EOL shows up on a loudspeaker line as a mostly capacitive load of 30 nF, representing a reactive load of 1.7 W when measured with an impedance meter at 1 kHz. The device will not dissipate this amount of power as it is reactive.

## 10.7

## Approvals

<b>Emergency standard certifications</b>	
Europe	EN 54-16 (0560-CPR-182190000)
International	ISO 7240-16
Maritime applications	DNV GL Type Approval
Mass Notification Systems	UL 2572 (PRA-EOL-US only)
Control Units and Accessories for Fire Alarm Systems	UL 864 (PRA-EOL-US only)
<b>Emergency standard compliance</b>	
Europe	EN 50849
UK	BS 5839-8
<b>Regulatory areas</b>	
Safety	EN/IEC/CSA/UL 62368-1
Immunity	EN 55035 EN 50130-4
Emissions	EN 55032 EN 61000-6-3 EN 62479
Environment	EN/IEC 63000
Plenum rating	UL 2043
Railway applications	EN 50121-4

## 10.8

## Technical data

## Electrical

<b>Electrical control</b>	
Pilot tone frequency (kHz)	25.50 kHz
Pilot tone level (V)	1.5 V – 3 V
Maximum input power (mW)	100 mW
Maximum input voltage (V)	100 V
Supervision	End-of-line
Fault detection	Line shorted; line interrupted
Fault reporting	Via amplifier
<b>Electrical connectivity</b>	
Connector type	2-pole spring terminal
Wire size (mm <sup>2</sup> )	0.13 mm <sup>2</sup> – 2.0 mm <sup>2</sup>

Wire size (AWG)	26AWG – 14AWG
Cable length (m) (maximum)	1000 m
Maximum cable capacitance (nF)	80 nF
Cable temperature range (°C)	-20 °C – 50 °C
Cable temperature range (°F)	-4 °F – 122 °F

<b>Reliability</b>	
MTBF (extrapolated from calculated MTBF of PRA-AD608)	5,000,000 h

**Environmental**

<b>Operating temperature (°C)</b>	<b>-25 °C – 50 °C</b>
Operating temperature	-13 °F – 122 °F
Storage temperature	-30 °C – 70 °C
Storage temperature	-22 °F – 158 °F
Operating relative humidity, non-condensing	5% – 95%
Air pressure	56 hPa – 1070 hPa
Installation altitude	-500 m – 5000 m
Installation altitude	-1640 ft – 16404 ft
Operating vibration amplitude (mm)	< 0.7 mm
Operating vibration acceleration (G)	< 2 G
Bump (transport)	< 10 G (IEC 60068-2-27)

**Mechanical**

Dimension (H x W x D) (mm), board shape	60 mm x 78 mm x 16 mm
Dimension (H x W x D) (in.), board shape	2.4 in x 3.1 in x 0.6 in
Dimension (H x W x D) (mm), box shape	60 mm x 45 mm x 18 mm
Dimension (H x W x D) (in), box shape	2.4 in x 1.8 in x 0.7 in
Degree of protection (IEC 60529)	IP30
Material	Plastic
Color in RAL	RAL 3000 Flame red
Weight (g)	25 g
Weight (lb)	0.055 lb

# 11 Multifunction power supply, large (MPS3)



## 11.1 Introduction

This compact device combines multiple support functions to power and serve other PRAESENSA system devices.

It can be used in a centralized system, but it is an enabler for decentralized system topologies with several smaller racks or cabinets located across the premises, to reduce loudspeaker cabling costs significantly.

It provides DC-power supply to connected amplifiers and peripherals from the mains, with a standards compliant charger for a single 12 V backup battery, saving on installation and battery maintenance costs.

The integrated 6-port Ethernet switch, with glass fiber support, facilitates easy interconnection of decentralized clusters of devices.

Configurable, supervised control inputs and voltage-free control outputs are available as interface to external equipment. Its OMNEO interface for control and fault reporting also provides an analog audio backup lifeline for the connected amplifiers.

## 11.2 Functions

### Independent mains power supplies

- Three fully independent 48 VDC power supplies for up to three amplifiers.
- One 24 VDC output for a system controller or auxiliary device.
- All power supply outputs have double connectors for A/B dual redundant wiring to the connected loads.
- A fault condition on one of the outputs does not affect any of the other outputs.
- Universal mains input with power factor correction to maximize the amount of power that can be taken from a single phase power distribution network.

### Backup battery solution

- Integrated charger for a 12 V VRLA (Valve Regulated Lead-Acid) battery, with a capacity up to 230 Ah for standards compliant charging and energy storage.
- The battery life time for servicing is maximized by using a single 12 V battery that has all six battery cells at the same temperature and all cells using the same electrolyte. This prevents unequal charging and consequently overcharging of series connected batteries, which is the main cause of premature battery aging.
- Three fully independent battery to 48 VDC power converters for up to three amplifiers.
- Flexible, pre-terminated battery cabling of fixed length included, with fuse and battery temperature sensor, for fast battery connection and predictive cabling resistance.
- Accurate battery impedance measurement to monitor aging of the battery and supervision of battery connections.

**Ethernet switch**

- Six OMNEO network ports, supporting Rapid Spanning Tree Protocol (RSTP), for loop-through connections to adjacent devices:
  - Five ports are for copper connection on RJ45, two of them provide Power over Ethernet (PoE) to supply power to connected call stations or other devices.
  - One port provides an SFP-cage for Small Form-factor Pluggable transceivers for single or multi-mode glass fiber connections.

**General purpose control inputs and outputs**

- Eight control inputs to receive signals from external systems with configurable connection supervision.
- Eight voltage free single pole, double throw (SPDT) relay contacts to activate external devices.
- Control input and output functions are software configurable.

**Fault tolerance and supervision**

- Supervision of mains, battery and device operation and all connections; faults are reported to the system controller and logged.
- Automatic battery backup takeover from mains in case of mains failures.
- Multi-port network interface with RSTP-support for recovery from a failing network connection.
- Supervised audio lifeline to connected amplifiers, as backup for a failing amplifier network interface.

# 11.3 Functional diagram

Functional and connection diagram

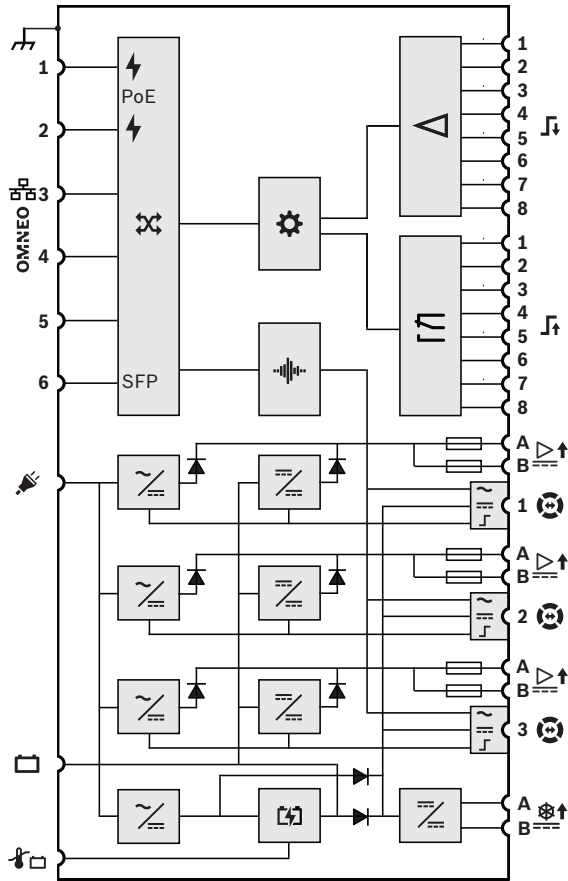

Internal device functions

- Power over Ethernet power source
- OMNEO network switch
- SFP** Socket for SFP module
- Controller
- Audio processing (DSP)
- Mains to DC converter
- DC to DC converter
- Battery charger
- Control input processor
- Control output relay
- Lifeline audio output
- Lifeline supply output
- Lifeline control interface
- Diode
- Fuse

# 11.4 Indicators and connections



### Front panel indicators

	48 VDC amplifier power supply A-B (1-3) Power on Fault	Green Yellow		24 VDC auxiliary power supply A-B Power on Fault	Green Yellow
	Device fault present	Yellow		Network link to system controller present Network link lost	Green Yellow
	Battery status Full (float charging) Charging (bulk or absorption charging) Fault	Green Green blinking Yellow		Mains present Mains fault	Green Yellow
	Identification mode / Indicator test	All LEDs blink			

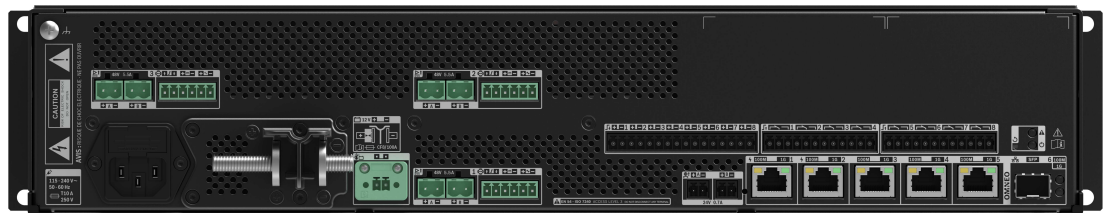









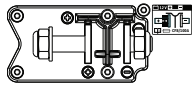

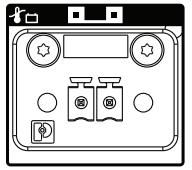

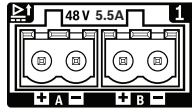

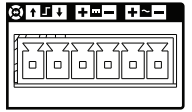
### Rear panel indicators and controls

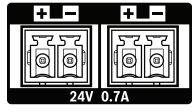
	100 Mbps network 1 Gbps network	Yellow Green		Device fault present	Yellow
	Power on	Green		Device reset (to factory default)	Button
	Identification mode / Indicator test	All LEDs blink			

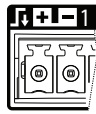
### Rear panel connections

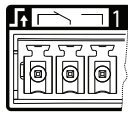
	Chassis ground			Mains input with fuse	
--	----------------	--	--	-----------------------	--

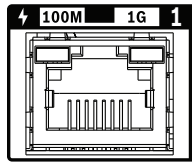
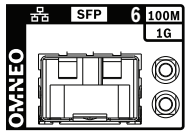
	Battery 12 VDC (==)			Battery temperature sensor	
	48 VDC output A-B (1-3, to amplifier 1-3)			Lifeline control/audio/supply interface (1-3, to amplifier 1-3)	
	24 VDC output A-B (to system controller)				
	Control input 1-8			Control output 1-8	
	Network port 1-5 (port 1 and 2 with PoE)			Network port 6 (SFP)	

## 11.5

### Installation

The device is designed to be installed in a 19"-rack/cabinet. Refer to: *Mounting the 19"-rack devices, page 27.*

The device can be connected everywhere within the PRAESENSA system. If required, refer to: *System introduction, page 19.*

### 11.5.1

#### Parts included

The box contains the following parts:

Quantity	Component
1	Multifunction power supply
1	Set of 19"-rack mounting brackets (pre-mounted)
1	Set of screw connectors
1	Battery connection set (wiring, fuse, temperature sensor, nut caps)
1	EU power cord CEE 7/7 to IEC C13
1	US power cord NEMA 5-15 to IEC C13
1	Quick Installation Guide
1	Safety information

No tools or Ethernet cables are provided with the device.



**Parts check and identification**

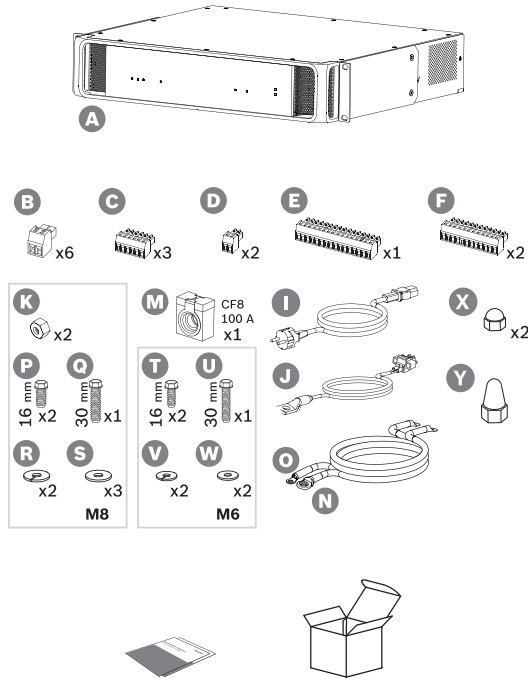

- A** Multifunction power supply
- B** 2-pole screw plug (x6)
- C** 6-pole screw plug (small, x3)
- D** 2-pole screw plug (small, x2)
- E** 16-pole screw plug (small)
- F** 12-pole screw plug (small, x2)
- I** Mains power cord
- J** Temperature sensor assembly
- K** Nut M8 (x2)
- M** Battery fuse CF8 100 A
- N** Positive battery cable (red)
- O** Negative battery cable (black)
- P** Bolt M8 (short, x2)
- Q** Bolt M8 (long)
- R** Spring washer M8 (x2)
- S** Washer M8 (x3)
- T** Bolt M6 (short, x2)
- U** Bolt M6 (long)
- V** Spring washer M6 (x2)
- W** Washer M6 (x2)
- X** Nut cap M8 (short, 2x)
- Y** Nut cap M8 (long, 1x)

**11.5.2**

**Battery and fuse**

For compliance to EN 54-16 and other voice alarm standards, the PRA-MPS3 uses an external 12 V VRLA (Valve Regulated Lead Acid) battery as backup power source. In case a backup battery is not a requirement, it can also be used without a battery. It uses internal DC/DC converters to convert the battery voltage to the required supply voltages for the connected PRAESENSA devices. A 100 A fuse (model CF8) (M) must be used in series with the positive (red) cable (N) of the battery. It is recommended to mount the fuse at the battery side (see chapter below), immediately at the positive battery terminal. Alternatively the fuse can be mounted at the power supply side (see chapter below), when local standards require so. Never use two fuses, one on each side, because this would increase the series resistance of the cable assembly and the high peak currents of a system in emergency mode would result in voltage dips that could limit the maximum available output

power to the loudspeakers. The connected battery must have a capacity of 100 to 230 Ah. The actual required capacity depends on many variables, see *Battery calculation*, page 55 for calculation guidelines. The device is delivered with cables with crimp eyelet terminals (N + O) and it is recommended to use these full length cables. Although a shorter cable is better, it requires heavy tools to shorten a cable and fix new eyelet terminals.

The temperature sensing assembly (J) is used to sense the temperature of the battery for best performance. The temperature of the negative battery terminal is a good representation of the internal battery temperature. Temperature sensing is an important requirement to set the correct charging threshold voltages to fully charge the battery without overcharging. When the temperature sensor is not mounted correctly, the battery lifetime may be considerably reduced. When the sensor is not connected, the battery charger will be switched off. Only use the temperature sensor assembly that is delivered with the device.

---

#### Notice!

To comply EN 54-4 / ISO 7240-4, the battery needs to:

- Be rechargeable.
- Be suitable to be maintained in a fully charged state.
- Be constructed for stationary use.
- Be marked with the type designation and date of manufacture.
- Be of the sealed type.
- Be mounted in accordance with the manufacturer's data.

A properly marked and mounted VRLA (Valve Regulated Lead Acid) battery of 12 V satisfies these requirements. SLA (Sealed Lead Acid) and VRLA are different acronyms for the same battery. This battery type is maintenance-free, leak-proof and position insensitive. Batteries of this type have a safety vent to release gas in case of excessive internal pressure build up. You can also use AGM (Absorbed Glass Mat), which refers to a specific type of SLA or VRLA.



---

#### Caution!

1. The battery must be electrically floating. Never connect any battery terminal to ground. Wire the battery terminals individually to the battery connection terminals of the PRA-MPS3.
2. A battery cannot be connected to more than one PRA-MPS3. This means that it cannot be shared by multiple power supplies.
3. Risk of explosion if an incorrect type of battery is used.



---

#### Notice!

1. To prevent damage to the battery always make sure the depth of the threaded insert of the terminals before tightening the bolts. If needed, use shorter bolts.
2. Make sure to tighten all connections with the correct torque. Not only to prevent damage, but also to keep the contact resistances as low as possible. Keep the red and black battery cables together and aligned for most of their length with cable ties or heat shrink sleeves. This reduces cable inductance and improves the accuracy of the battery impedance measurement because the battery impedance is measured with an AC current. The inductance of the cables is very low and can seem insignificant. However, the impedance of the battery and the resistance of the cables, of the cable connections and of the fuse are also very low. These elements are in a series and are measured together.
3. Do not connect any external load to the battery directly. This will disturb the charging process.



### Battery and charging stages

The charger of the multifunction power supply is a 3-stage charger. This is a processor-controlled charger that offers maximum safety and ease of use, while preserving best performance and battery lifetime. Recharging a battery is a three stage process:

- **Stage 1 (bulk charge):** In this stage the battery is charged with a constant current, the nominal charging current of 8.5 A. The applied voltage increases over time to keep this current flowing while the battery charges. The actual voltage also depends on the internal resistance of the battery and the connection cable resistance. This stage will recharge batteries that are severely drained. There is no risk of overcharging in this stage because the battery hasn't reached full yet. The charger measures the battery voltage and, in combination with the actual temperature, decides on the state of charge of the battery. At a certain voltage, corresponding to a state of charge of the battery of 70-80%, the charger will enter the absorption stage. The battery status LED blinks green while in stage 1.
- **Stage 2 (absorption charge):** In this stage the charger maintains a steady voltage, while the charging current declines. The lower current going into the battery safely brings up the charge on the battery without overheating it. This stage takes more time as the charging current is lower. The current continuously declines until the battery almost reaches full capacity. Then the charger will enter the float stage. The battery status LED still blinks green while in stage 2.
- **Stage 3 (float charge):** The float stage charges the battery to full and maintains the 100% state of charge. The voltage will decrease and stays at a steady voltage of around 13.5 V (the exact value adapts to the temperature), which is the maximum voltage a 12 V VRLA battery can hold. The current will also decrease to the point of trickle charging. It's essentially the float stage where there is charge going into the battery at all times, but only at a safe rate to ensure a full state of charge and nothing more. The charger does not turn off at this point. It is important that the battery is at 100% state of charge to utilize its full capacity when the PRAESENSA system needs to operate on backup battery, but this state of charge is also the healthiest regarding battery lifetime. In this stage 3, the battery status LED is steady green.

Battery lifetime is maximized by using a single 12 V battery, that has all six battery cells at the same temperature and all cells using the same electrolyte. All cell voltages will be substantially equal and the switch-over to the next charging state is well-defined. Series connected batteries without battery balancing circuits will not stabilize to the exactly same voltage, while the switch-over to the next charging state is determined by the summed voltages of the distinctive batteries. This causes non-optimum charging and consequently overcharging of one or more of the series connected batteries, which is the main cause of premature battery aging.

### Battery fault reporting

The battery is monitored continuously to prevent damage to the battery and to make sure that it is available in good state as a backup power source to the system in case of mains power failures. When a backup power source is not needed, it is allowed to not connect a battery to the multifunction power supply. In that case make sure that supervision of the battery is disabled in the configuration of the device to avoid that a battery missing fault is reported by the system.

When a battery is in fact connected, but the battery supervision is disabled in the configuration, then the battery will still be charged and used when mains power fails. In order to prevent damage to the battery, also battery supervision still continues in the background and even most battery faults will be reported as usual (voltage too high, voltage

too low, battery short circuit, temperature too high, leakage current too high, temperature sensor missing). Only the results of the battery impedance measurements are suppressed. This mode could be useful for special situations (not compliant to EN 54-16 and EN 54-4), where a relatively small backup battery is used, to avoid that a fault is reported that the battery impedance is too high. Make sure that this battery can handle a charging current of 8.5 A and the maximum current draw of the load, see section *Accurate battery size calculation*, page 61.

The fault message **Current leakage too high (charger function disabled)** only occurs when:

- The charging current is >1 A for more than one hour while the charger is in float charge mode (stage 3). This only occurs with a defect battery with a too high leakage current, or when more load is connected directly to the battery.
- The charging current is >1 A for more than 73 hours when the charger is in bulk charge (stage 1) or in absorption charge mode (stage 2). This does not occur with a good battery of up to 230 Ah. The charger typically charges such a battery within 48 hours (90 % in the first 24 hours).

### Fuse at battery side

Putting the fuse (M) at the positive battery terminal, follow the connection procedure below.

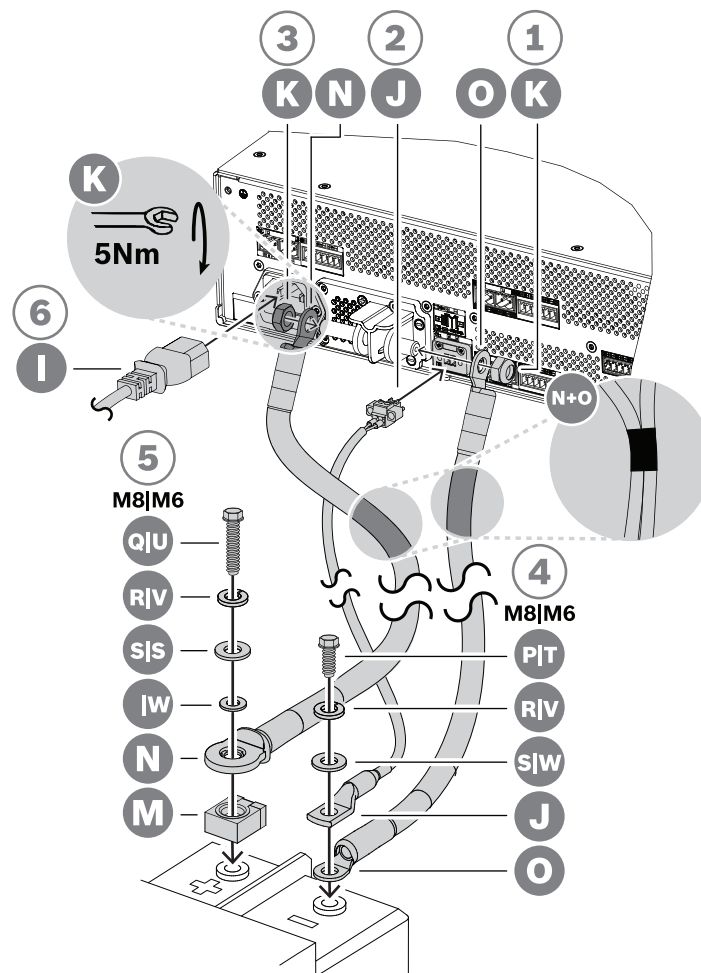

1. Take the black battery cable (O) and fix one side to the short negative battery connection terminal of the power supply, using an M8 self-locking nut (K). Tighten with torque 5 Nm.
  - When the black (O) and red (N) battery cables are fixed to each other, make sure that the isolated fuse eyelet on the red cable (N) is at the **battery side**, otherwise reverse the complete cable set.
2. Take the red battery cable (N) and fix the non-isolated eyelet to the long positive battery connection terminal, using the other M8 self-locking nut (K). Tighten with torque 5 Nm.
3. Push one of the short nut caps (X) on the nut of the negative connection terminal.
4. Push the long nut cap (Y) on the nut of the positive connection terminal.
  - The nut plastic caps provide additional protection against the short circuiting of the battery, to prevent the battery fuse from accidentally blowing.
5. Connect the open end of the black cable (O) to the negative battery terminal, with the eyelet of the temperature sensor (J) on top.
  - Depending on the type of battery and its terminals, use a short M8 bolt (P), spring washer (R) and washer (S), or short M6 bolt (T), spring washer (V) and washer (W).
  - M8 and M6 are the most common screw terminal types for VRLA batteries in PA/VA applications. Check the battery specification for the optimum tightening torque.
6. Put the fuse (M) on top of the positive battery terminal, then put the open end of the red cable (N) with the metal side of the isolated eyelet on top of the fuse and fix this set to the battery terminal with a long bolt, spring washer and washer (M8: Q, R, S / M6: U, V, W).
  - Tighten with the correct torque, according to the battery specification. The eyelet isolation of cable (N) is needed to prevent that the fuse is being shorted by the bolt (Q or U).

#### **Fuse at power supply side**

Putting the fuse (M) at the positive battery terminal of the power supply, follow the connection procedure below.

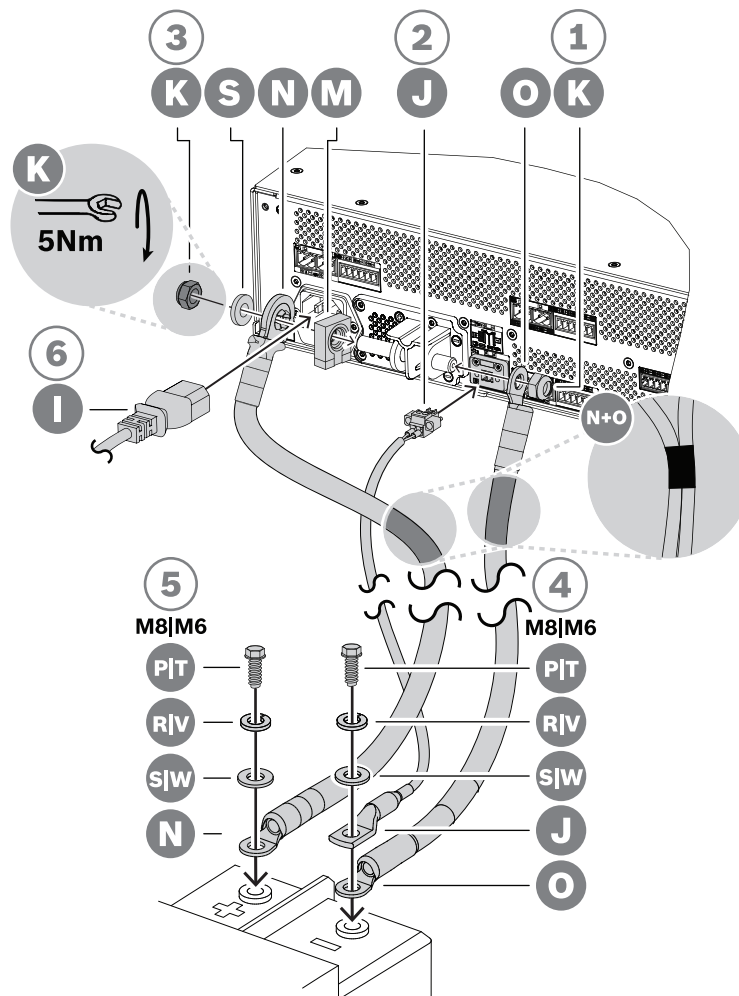

1. Take the black battery cable (O) and fix one side to the short negative battery connection terminal of the power supply, using an M8 self-locking nut (K). Tighten with torque 5 Nm.
  - When the black (O) and red (N) battery cables are fixed to each other, make sure that the isolated fuse eyelet on the red cable (N) is at the **power supply** side, otherwise reverse the complete cable set.
2. Put the fuse (M) on the long positive battery connection terminal of the power supply, followed by the isolated eyelet of the red cable (N), with the metal side of the eyelet against the fuse, then followed by a washer (S). Fix this set using the other M8 self-locking nut (K). Tighten with torque 5 Nm.
  - The eyelet isolation of cable (N) is needed to prevent that the fuse (M) is being shorted by the threaded end terminal.
3. Push the two short nut caps (X) on the nuts of the negative connection terminal and the positive connection terminal.
  - The nut plastic caps provide additional protection against the short circuiting of the battery, to prevent the battery fuse from accidentally blowing.
4. Insert the connector of the battery temperature sensor assembly (J) into the temperature sensor connector socket of the power supply.

5. Connect the open end of the black cable (O) to the negative battery terminal, with the eyelet of the temperature sensor (J) on top. Depending on the type of battery and its terminals, use a short M8 bolt (P), spring washer (R) and washer (S), or short M6 bolt (T), spring washer (V) and washer (W).
  - M8 and M6 are the most common screw terminal types for VRLA batteries in PA/VA applications. Check the battery specification for the optimum tightening torque.
6. Connect the open end of the red cable (N) to the positive battery terminal using a short bolt, spring washer and washer (M8: P, R, S / M6: T, V, W). Tighten with the correct torque, according to the battery specification.

#### Using a circuit breaker

Instead of using the 100 A CF8 fuse (M) that is delivered with the unit, it is possible to use a thermal or electro-magnetic circuit breaker. The circuit breaker can also serve to manually disconnect the battery from the PRA-MPS3. This could be convenient to power off a system for making modifications after installation of the battery. It is important to make sure that the breaking capacity of the circuit breaker is bigger than the short-circuit current of the installed battery. The short-circuit current of typical batteries for the PRA-MPS3 is 2 to 6 kA. Circuit breakers for 100 A for DC are available with a breaking capacity of 10 kA, both for panel mounting and for DIN-rail mounting.

The internal resistance of a 100 A circuit breaker is about the same as for the 100 A CF8 fuse (M), less than 1 mohm, so the impedance measurement of the battery circuit, which is a requirement of the voice alarm standards, is not affected. Do not use multiple fuses or circuit breakers in series or double-pole circuit breakers, as this will increase the impedance of the battery circuit and may generate a premature battery fault.



#### Battery cables

Battery cables are packed with the PRA-MPS3. These are heavy duty red (N) and black (O) cables of 120 cm length, with a cross section of 35 mm<sup>2</sup> (approximately AWG 2) and with crimp eyelet terminals attached. The wire resistance of each cable is approximately 0.7 mohm (together 1.4 mohm). It is important to keep the resistance of the battery circuit very low for the 12 V battery to be able to supply large (peak) currents without much voltage drop to the DC/DC converters for the amplifiers. For that reason only a single fuse with a resistance of 0.5 to 1 mohm is allowed. The supplied 100 A CF8 fuse (M) has a cold resistance of 0.6 mohm. The battery itself has an internal resistance that depends on the capacity of the battery. A new, charged 200 Ah battery (VRLA) of 12 V has an internal resistance of approximately 3 mohm.

When the supplied battery cables cannot be used, it is possible to use alternative cables, as long as the total wire resistance remains below 2 mohm, and the lower it is, the better. That value is for a PRA-MPS3 with three amplifiers connected, each loaded with 600 W of loudspeakers. But even when less amplifiers are connected or less loudspeaker load is connected, it is still good to select a cable type and length that fits to a maximum configuration. Then, amplifiers and load can be added later without having to change battery cables.

For installation, it is very convenient when the cables are very flexible. In the metal industries, welding cables are used that are hard wearing and flexible, and designed to transmit high currents between the welding generator and electrodes. These cables are sometimes identified by codes H01N2-D for flexible cables and H01N2-E for very flexible cables, in accordance with EN 50525-2-81. Useful sizes are 10, 16, 25, 35 and 50 mm<sup>2</sup> and AWG sizes 6 to 1. Welding cables are available with red and black colored insulation and ideal for making the connections between the PRA-MPS3 and the battery. Especially in racks, where the equipment is mounted in a swing frame, flexibility of the cables is important.

Wire gauge [AWG]	Wire cross section [mm <sup>2</sup> ]	Wire resistance [mohm/m]	Maximum length per wire [cm]
	<b>10</b>	1.95	50
<b>6</b>	(13.3)	1.47	60
	<b>16</b>	1.22	70
<b>5</b>	(16.8)	1.16	80
<b>4</b>	(21.1)	0.92	100
	<b>25</b>	0.78	120
<b>3</b>	(26.7)	0.73	130
<b>2</b>	(33.6)	0.58	170
	<b>35</b>	0.55	180
<b>1</b>	(42.4)	0.46	210
	<b>50</b>	0.39	250

### New batteries

Often, new batteries do not give their rated capacity when received from the manufacturer. This happens due to the methods of making the plates. The plates are made by applying oxides of lead, mixed with a liquid, which is generally diluted sulfuric acid, to the grids. To produce the spongy lead and the lead peroxide, these oxides are subjected to a charging current. After the charge, the batteries are discharged, and then charged again. This cycle is necessary because not all the oxides are changed to active material on one charge. Repeated charges and discharges are required to produce the maximum amount of active materials.

Some manufacturers do not charge and discharge a battery enough times before sending it out. These manufacturers expect that, after a battery is put into use, its capacity will eventually increase to the specified value, because more active material is produced during each charge. Backup batteries, however, might never get enough discharge and charge cycles to reach that capacity.

Due to this reduction of active material, new batteries and batteries that have been stored for longer periods of time also show a relatively high internal resistance. A battery fault can be reported when the battery circuit resistance exceeds the threshold value for the configured battery size.



**Notice!**

For best performance, discharge and charge a battery several times. Every cycle will result in a reduction of the internal resistance and in an increment of the available capacity.

**11.5.3****Mains power connection**

1. Check that the mains (AC) power supply meets the nominal input rating of the PRA-MPS3.
  - The voltage that can be applied is any of the nominal power supply voltages in the range of 115 VAC to 240 VAC. The frequency is 50 Hz or 60 Hz.
2. Use the supplied power cord (I) to connect to the mains line.
  - If the supplied power cord cannot be used due to the plug shape, have a qualified engineer replace it with an appropriate power cord of length 3 m or less.
  - The PRA-MPS3 uses an IEC 60320 - C14 appliance inlet; the mains cord must have a matching C13 connector.
  - The PRA-MPS3 has no power switch.

**Notice!**

The power cord with a plug can be used to disconnect the PRA-MPS3 from the mains. Connect the plug to an easily accessible power outlet so that the plug can be removed from the outlet at any time. Be sure to allow enough space around the power outlet.

3. The mains inlet has a built-in fuse T10AH 250V.
  - The T-characteristic of this 10 A fuse refers to how rapidly it responds to various current overloads. This is a slow-acting fuse (Time-lag) that has additional thermal inertia, designed to tolerate normal initial or start-up overload pulses.
  - The H-characteristic of this 10 A fuse refers to being a High breaking fuse type.
  - Because the fuse is only connected in line with one of the mains conductors (L or N), never use the fuse as a means to interrupt the mains in case of service. Pull out the C13-connector of the power cord to disconnect the mains.

**Caution!**

Only replace with a fuse of the same type, certified for IEC 60217 or UL 248.

**Dual feed mains power**

Public Address and Voice Alarm systems often include a battery backup power supply for continuous operation, as protection against a failing mains input. This is also a requirement of most standards for voice alarm systems and an integrated feature of PRAESENSA.

However, data centers, hospitals, factories and a wide range of other facility types that require continuous or near-continuous uptime typically utilize an emergency (secondary) power source such as a generator or a backup utility feed when their normal (primary) power source becomes unavailable. This alternate power source can also be used for PRAESENSA, with or without local battery backup.

To transfer the load connection from a primary to a secondary source of electrical power, an automatic power transfer switch (APTS, ATS or PTS) is used. An APTS is a self-acting, intelligent power switching device governed by dedicated control logic. The principal purpose of an APTS is to ensure the continuous delivery of electrical power from one of two power sources to a connected load circuit.

The control logic or automatic controller is typically microprocessor-based and constantly monitors the electrical parameters, such as voltage and frequency of the primary and secondary power sources. Upon failure of a connected power source, the APTS will automatically switch the load circuit to the other power source (if it is available). As a general rule, most automatic transfer switches seek connection to the primary power source (utility) by default and will only connect to the alternate power source (engine-generator, backup utility) when required.

Depending on the type of secondary power source, there might be a gap between the moment the primary power source fails and the moment the secondary power source becomes available and is stable enough for the APTS to switch over. The PRA-MPS3 can bridge that gap by using its battery backup during that time. A relatively small battery is sufficient in that case. Most power transfer switches provide a fault-relay output that can be connected to one of the control inputs of the PRA-MPS3 to report the power transfer in the PRAESENSA fault log.

#### 11.5.4

#### Amplifier power supply

The multifunction power supply has three independent 48 VDC outputs to supply power to three PRAESENSA 600 W power amplifiers. Each output has dual A/B connectors for connection and cable redundancy. This is especially useful when the amplifiers and the power supply are not in the same rack and the power supply cable is accessible or vulnerable. It is recommended to always use both connections.

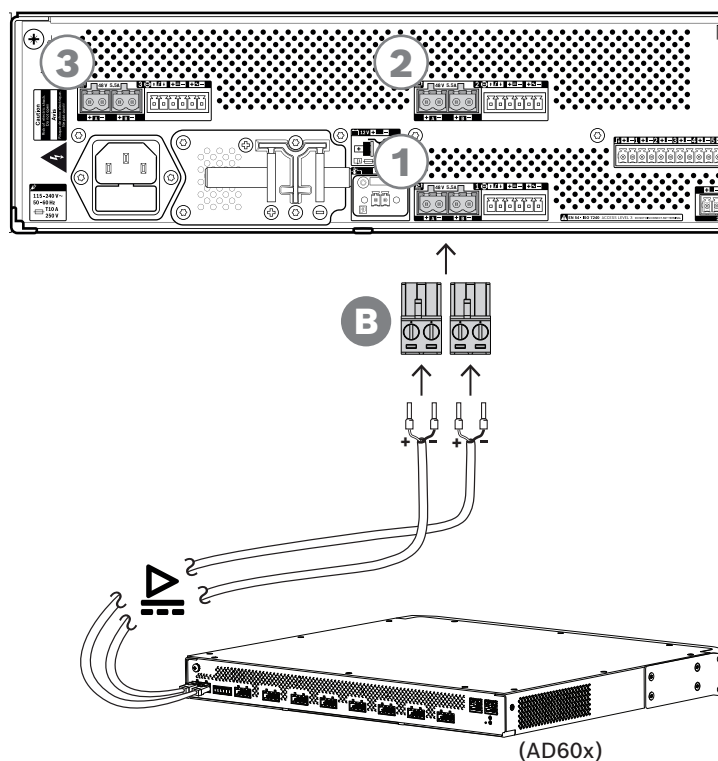

**Connection procedure**

1. The power supply interconnection wiring and ferrules are delivered with the amplifier.
  - The power supply terminal plugs (B) are delivered with the multifunction power supply.
2. Follow the power supply cable assembly instructions as provided for the amplifiers.
  - Observe polarity.
3. Insert the power supply terminal plugs of the interconnection cables into the A/B sockets of one of the three 48 VDC outputs.
  - It is good practice to connect output A of the power supply to input A of the amplifier and the same for B. Cross coupling is allowed, but may be confusing in case of fault finding.

**Caution!**

The 48 V power supply outputs A and B are separately fused with internal fuses. Refer to *Functional diagram, page 134*. Outputs A and B make redundant connections to the load. A short circuit in one of the output lines should not bring down the other line. When an output is shorted, its fuse will blow to protect the other output. Do not cause short circuits in the wiring between the 48 V outputs and the load. These fuses cannot be replaced by the user. The fuses protect against short circuits while the system is in operation, to maintain redundancy. They do not protect against wiring mistakes.

**Caution!**

For compliance to UL 62368-1 and CAN/CSA C22.2 No. 62368-1 the power supply wiring must be Class 1 wiring (CL1); this requirement does not apply for compliance to EN/IEC 62368-1.

**Refer to**

- *Functional diagram, page 134*

**11.5.5****Lifeline**

The lifeline is an optional cable connection between a PRAESENSA amplifier and a PRAESENSA multifunction power supply. This interconnections serves multiple functions:

- The multifunction power supply provides the audio signal of the highest priority emergency call as a balanced line level analog signal on the lifeline connector (pins 5 and 6). This signal is a backup audio signal for the connected amplifier in case its network interface or both network links would fail. The emergency call will then be distributed to all connected loudspeakers at maximum volume and without equalization or audio delay. The lifeline signal goes straight to the spare amplifier channel to drive all zones in parallel. This line is supervised by the multifunction power supply.
- The multifunction power supply sends information (pin 1) to the connected amplifier about the availability of mains power. In case mains power fails and power is provided from the battery, this signal sets the amplifier in backup power mode to disable all amplifier channels that are not needed to make calls with a priority above the configured priority level for the backup power mode. When no high priority calls are being made via this amplifier, it informs the multifunction power supply (pin 2) to switch off the 48 V converters to minimize battery power consumption even more. The power supplies and the amplifier channels go to snooze mode and wake up every 90 seconds briefly to perform the required supervision actions for timely fault reporting.

- The multifunction power supply provides the battery or charger voltage, in the range of 12 to 18 V, to the amplifier directly (pins 3 and 4) to supply power to the amplifier's network interface while the 48 V power supplies are switched off.

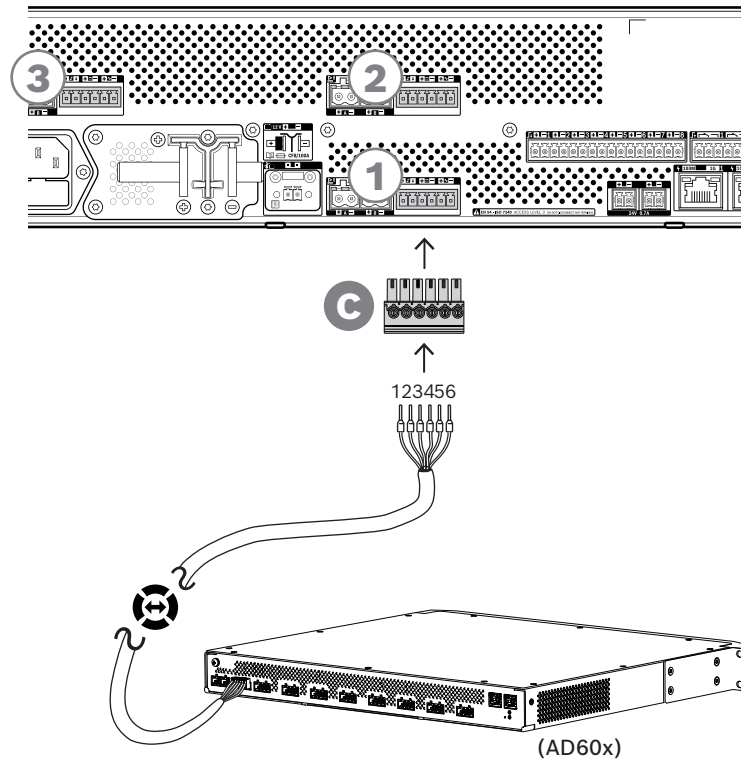

**To complete the lifeline interconnection follow the procedure below:**

1. The 6-pole cable and connector for the amplifier are delivered with the amplifier. For lifeline assembly instructions, refer to the following sections: *Lifeline*, page 92 and/or *Lifeline*, page 110.
2. The 6-pole connector (C) for the multifunction power supply is delivered with the power supply.
3. Mount the connector (C) to the cable, following the same wire order as for the amplifier side, the cable should be reversible.
4. Insert the connector (C) into the lifeline socket of the multifunction power supply, using the socket next to the 48 V outputs that go to the same amplifier.



**Caution!**

For compliance to UL 62368-1 and CAN/CSA C22.2 No. 62368-1 the lifeline wiring must be Class 1 wiring (CL1); this requirement does not apply for compliance to EN/IEC 62368-1.



**Notice!**

Each pair of 48 V outputs A/B and the lifeline next to it belong to each other and are always connected to the same amplifier. Keep the cables together to avoid errors that could result in no sound in case of emergencies.

### 11.5.6 Power supply connection to system controller

The multifunction power supply has one 24 VDC output to supply power to a PRAESENSA system controller or to power an auxiliary device like an Ethernet switch. The output has dual A/B connectors for connection and cable redundancy. This is especially useful when the system controller and the power supply are not in the same rack and the power supply cable is accessible or vulnerable. It is recommended to always use both connections.

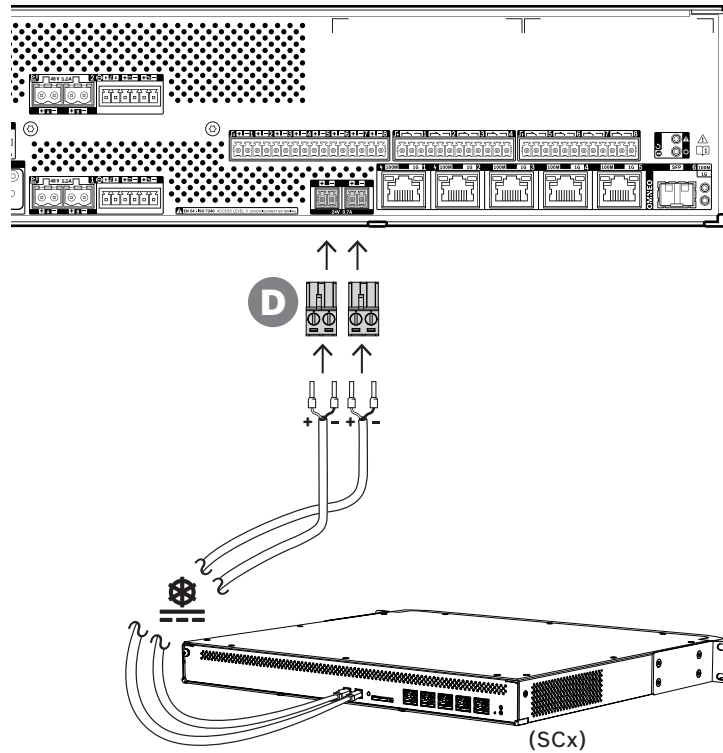

**Connection procedure:**

1. The power supply interconnection wiring and ferrules are delivered with the system controller. The power supply terminal plugs (D) are delivered with the multifunction power supply.
2. Follow the power supply cable assembly instructions as provided for the system controller.
  - Observe polarity.
3. Insert the power supply terminal plugs (D) of the interconnection cables into the A/B sockets of the 24 VDC output.
  - It is good practice to connect output A of the power supply to input A of the amplifier and the same for B. Cross coupling is allowed, but may be confusing in case of fault finding.



**Caution!**

For compliance to UL 62368-1 and CAN/CSA C22.2 No. 62368-1 the power supply wiring must be Class 1 wiring (CL1); this requirement does not apply for compliance to EN/IEC 62368-1.

**Notice!**

The power connections from the 24 V output may not be longer than 3 m.

**11.5.7****Power over Ethernet**

The multifunction power supply has an integrated Ethernet switch with 6 external ports. Ports 1 and 2 provide Power over Ethernet (PoE), next to OMNEO and other Ethernet data, present on the network. These ports can be used to connect one or two call stations, or other devices that are powered via PoE. Each port is capable of providing enough power for a call station with four extensions, which is the maximum. A PRAESENSA call station has two Ethernet ports and can be connected with two cables for fail safe cable redundancy. It is also possible to connect a call station to two separate multifunction power supplies for additional protection against failure of its Ethernet switch. Ports 3 to 5 cannot be used for PoE powering.

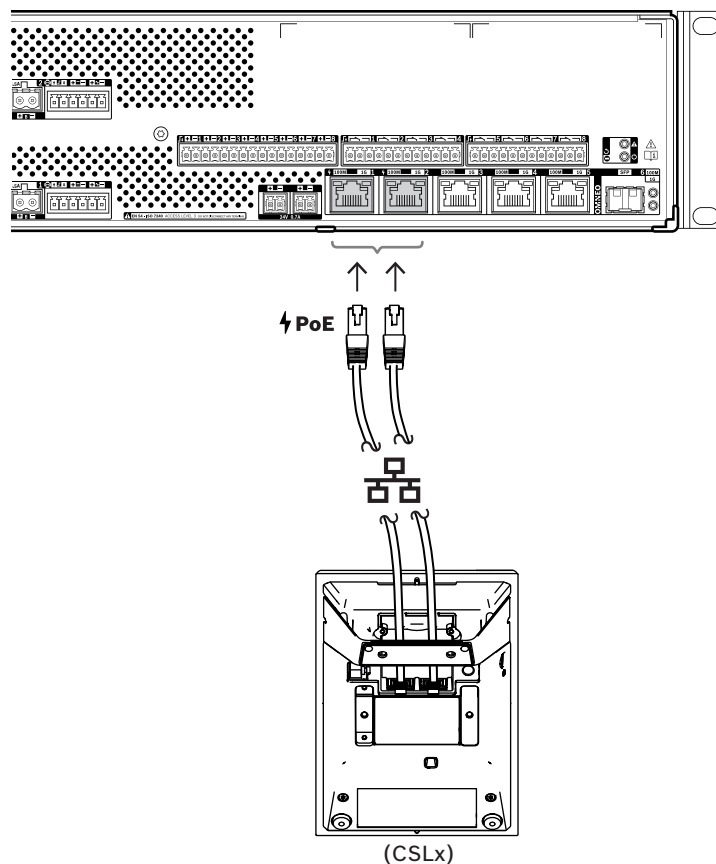

PoE devices can simply be connected using shielded Gb-Ethernet cables (preferably CAT6A F/UTP) with RJ45 connectors. All PRAESENSA devices support Rapid Spanning Tree Protocol (RSTP) to enable the use of multiple connections simultaneously for cable redundancy, e.g. to daisy-chain devices in a loop, with a maximum of 21 devices in a loop.

**11.5.8****Ethernet network**

The multifunction power supply has six Ethernet connection ports with a built-in Ethernet switch, supporting RSTP. Follow the procedure below to connect the device to a network and other system devices.

The network must be set up in such a way that the multifunction power supply can be discovered and reached by the system controller.

Configuration of the multifunction power supply is done via the system controller. For configuration, the device is identified by its hostname, which is printed on the product label on the rear side of the device. The format of the hostname is the type number of the device without the dash, followed by a dash and then the last 6 hexadecimal digits of its MAC-address. Configuration is described in the PRAESENSA configuration manual.

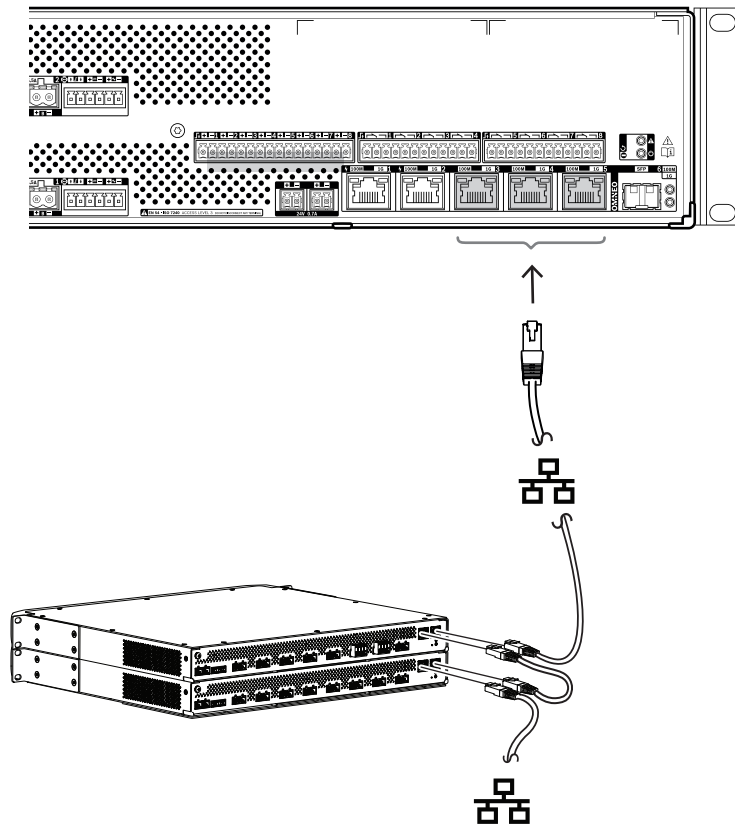

1. Connect at least one of the ports to the network, so that it can be discovered by the system controller to make it part of the system.
2. The other ports can be used for a loop-through connection to a next device. Devices can just be daisy-chained or be connected in a loop, in which case the system can recover from a broken link.
3. The availability of a multi-port switch makes the multifunction power supply an ideal device for decentralized system clusters that are interconnected to create a large system. One or more of these multifunction power supplies in cluster can be easily interconnected to other clusters, while the remaining ports are used to connect loops of other devices in that cluster.
4. Port 6 is an SFP socket for a Small Form-factor Pluggable module. This allows for a long distance connection using glass fiber to the next cluster. In case two glass fiber connections are needed, e.g. to make the devices in the cluster part of a long distance fiber ring, at least two fiber ports are needed from two multifunction power supplies, or from a stand-alone network switch with two SFP sockets, or a combination of these.

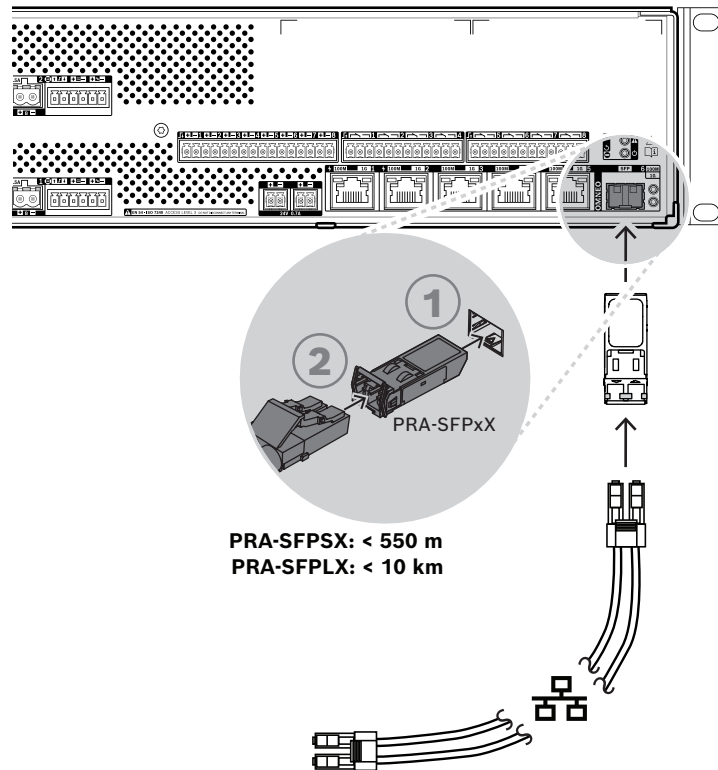

### Caution!

Risk of eye injury. When inspecting a connector, ensure that light sources are off. The light source in fiber optic cables may cause eye injury. SX and LX fiber connections use invisible IR light.

## 11.5.9

### Control inputs

The multifunction power supply provides eight control inputs on a 16-pole connector. The control inputs can be configured independently for various actions, with activation on closing a contact or opening a contact, and with or without interconnection supervision. See the PRAESENSA configuration manual for all options.

In case no interconnection supervision is configured, just use a switch or a relay output from another system for activation.

If a control input is used for activation of emergency calls, interconnection supervision is needed to generate a fault warning in case of an open or shorted circuit. In that case two resistors with value 10 kohm (0.25 W) must be connected between the cable and the switch. The resistors are connected in such a way that the control input sees 20 kohm for an open contact and 10 kohm for a closed contact. In case of a cable interruption, the control input sees a very high resistance. In case of a cable short-circuit, the control input sees a very low resistance. A very high or very low resistance will be interpreted as a fault condition.



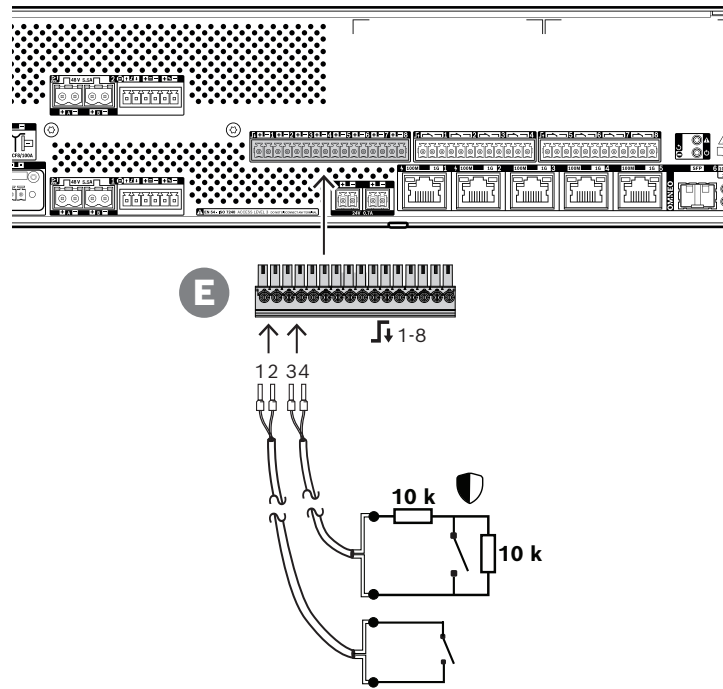

**How to connect, with and without supervision**

1. Use a 2-wire cable, proper for the installation, and the 16-pole terminal plug (E) delivered with the device.
2. Insert the near end wires of the cable into the appropriate slots of terminal plug (E), preferably using crimped on wire ferrules that fit to the wire gauge used.
  - Use a flat blade screw driver to tighten each connection.
3. **No supervision:** connect the other side of the cable to the activation switch or voltage free relay contact.
4. **With supervision:** connect the other side of the cable to the combination of activation switch and two 10 kohm supervision resistors. One resistor is in series with the switch and one resistor is in parallel with the switch.



**Notice!**

Do not use any terminal in common with other control input terminals.

**Effects of interconnection faults**

The control inputs 1-8 can be supervised to detect interconnections faults, both interruptions and short circuits. A detected fault affects the behavior of the associated input.

- Control inputs 1-8 with a connection supervision fault present do not act on input contact changes unless the change creates a valid input state (8 – 12 kohm or 18 – 22 kohm contact resistance).
- An emergency call that started by an activated input proceeds when a connection fault occurs for that input. A lower priority action that is started by an activated input is aborted when a connection fault occurs for that input.

## 11.5.10

### Control outputs

The multifunction power supply provides eight control outputs on two 12-pole connectors. The control outputs use an SPDT (Single Pole Double Throw) relay for each output, providing an NC (Normally Closed) and an NO (Normally Open) contact. The control outputs can be configured independently for various actions. Make sure not to exceed the maximum contact rating.

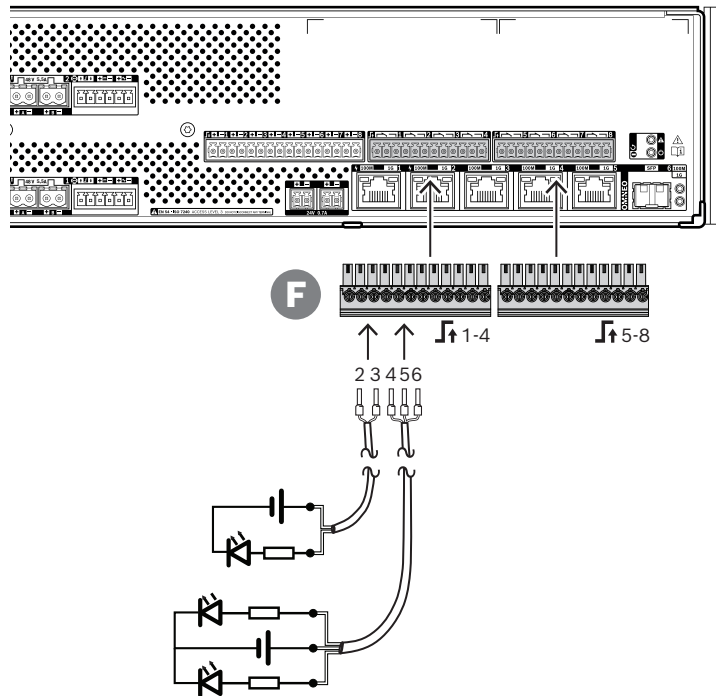

#### Connection procedure

1. Use a 2-wire or 3-wire cable, proper for the installation and application, and one of the 12-pole terminal plugs delivered with the device.
2. Insert the near end wires of the cable into the appropriate slots of terminal plug (F), preferably using crimped on wire ferrules that fit to the wire gauge used.
  - Use a flat blade screw driver to tighten each connection.
3. Connect the other side of the cable to the application to be activated.

## 11.5.11

### Reset to factory default

The reset switch resets the device to its factory default settings. This function is only to be used in case a secured device is removed from a system to become part of another system. See *Device status and reset*, page 71.

## 11.6

## Approvals

<b>Emergency standard certifications</b>	
Europe	EN 54-16 (0560-CPR-182190000) EN 54-4 (0560-CPR-222190016)
International	ISO 7240-16 ISO 7240-4
Maritime applications	DNV GL Type Approval
Mass Notifications Systems	UL 2572
Control Units and Accessories for Fire Alarm Systems	UL 864
<b>Emergency standard compliance</b>	
Europe	EN 50849
UK	BS 5839-8
Australia	AS 7240.4
<b>Regulatory areas</b>	
Safety	EN/IEC/CSA/UL 62368-1
Immunity	EN 55035 EN 50130-4
Emissions	EN 55032 EN 61000-3-2 EN 61000-3-3 EN 61000-6-3 ICES-003 FCC-47 part 15B class A EN 62479
Environment	EN/IEC 63000
Railway applications	EN 50121-4

## 11.7

## Technical data

## Electrical

Power transfer	
Mains power supply input	
Input voltage range	120 – 240 VRMS
Input voltage tolerance	108 – 264 VRMS
Frequency range	50 – 60 Hz
Inrush current (EN 61000-3-3)	20 ARMS
Power factor (PF)	0.9 – 1.0
Leakage current to safety ground	< 0.75 mA (120 V), < 1.5 mA (240 V)
Battery power supply input	
Nominal DC input voltage	12.6 V
DC input voltage tolerance	9 – 15 V
Maximum current	90 A
Under-voltage protection	< 9 V
Battery charger	
Nominal charging current	8.7 A
Nominal float voltage	13.7 V
Float voltage control	-21.9 mV/°C
Temperature sensor NTC	10 kohm / $\beta = 3984$ K
Charging temperature range	-15 – 50 °C
48 VDC outputs (1-3)	
Nominal DC output voltage	48 V
Maximum continuous current	5.5 A
Maximum peak current	7.0 A
24 VDC output	
Nominal DC output voltage	24 V
Maximum continuous current	0.7 A
Maximum peak current	0.9 A
Lifeline DC outputs (1-3), only when 48 VDC outputs (1-3) are off	
Nominal DC output voltage	18 V
Maximum continuous current	0.7 A
Maximum peak current	1.0 A
Power over Ethernet (PoE 1-2)	
Nominal DC output voltage	48 V
Standard	IEEE 802.3af Type 1
Maximum PD load	12.95 W
Power consumption	
Mains powered	
Active mode, all outputs loaded	<1150 W
Battery powered	
Unloaded	5.2 W

<b>Power transfer</b>	
Active mode, all outputs loaded	<1000 W
Per active port	0.4 W
Per active SFP port	0.7 W
Lifeline / power save interface	
Audio level (100 V / 70 V mode)	0 dBV / -6 dBV
Frequency response (+0 / -3 dB)	200 Hz – 15 kHz
Signal to Noise Ratio (SNR)	90 dBA
<b>Information related to EN 54-4:1997 / ISO 7240-4:2017 / AS 7240.4:2018</b>	
Maximum battery capacity	230 Ah
Lowest discharge voltage	9 V
Continuous output current (I max. a / I max. b / I min.)	
48 VDC outputs (1-3)	5.5 A / 5.5 A / 0 A
24 VDC output	0.7 A / 0.7 A / 0 A
PoE output (1-2)	0.3 A / 0.3 A / 0 A
Lifeline DC outputs (1-3)	0.7 A / 0.7 A / 0 A
Continuous output power (P max. a / P max. b / P min.)	
48 VDC outputs (1-3)	264 W / 264 W / 0 W
24 VDC output	16.8 W / 16.8 W / 0 W
PoE output (1-2)	15.4 W / 15.4 W / 0 W
Lifeline DC outputs (1-3)	12.6 W / 12.6 W / 0 W
Output voltage range	
48 VDC outputs (1-3)	46 – 50 V
24 VDC output	23 – 25 V
PoE output (1-2)	44 – 57 V
Lifeline DC outputs (1-3)	9 – 18 V
Maximum impedance of battery circuit	
230 Ah battery	7.1 mohm
180 Ah battery	8.6 mohm
140 Ah battery	9.8 mohm
100 Ah battery	11.0 mohm
<b>Control interface</b>	
Control input contacts (1-8)	
Principle	Contact closure
Galvanic isolation	No
Supervision	Resistance measurement
Contact closed	8 – 12 kohm
Contact open	18 – 22 kohm
Cable fault detection	<2.5 kohm / >50 kohm
Minimum hold time	100 ms
Maximum voltage to ground	24 V

<b>Control interface</b>	
Control output contacts (1-8) Principle	Contact switch over (Relay SPDT)
Galvanic isolation	Yes
Maximum contact voltage	24 V
Maximum contact current	1 A
Maximum voltage to ground	500 V
<b>Supervision</b>	
Battery	Disconnect Short circuit Charging state Impedance
Power supplies	Converter voltages Output voltages
Lifeline connection	Impedance
Control input connections	Open / short
Temperature	Per section
Fan	Rotation speed
Controller continuity	Watchdog
Network interface	Link presence
<b>Network interface</b>	
Ethernet  Protocol Redundancy	100BASE-TX, 1000BASE-T  TCP/IP RSTP
Audio/control protocol Network audio latency Audio data encryption Control data security	OMNEO 10 ms AES128 TLS
Ports RJ45 SFP	5 (2 with PoE) 1
<b>Reliability</b>	
MTBF (extrapolated from calculated MTBF of PRA-AD608)	350,000 h

**Environmental**

<b>Climatic conditions</b>	
Temperature	
Operating	-5 – 50 °C (23 – 122 °F)
Storage and transport	-30 – 70 °C (-22 – 158 °F)
Humidity (non-condensing)	5 – 95%
Air pressure (operating)	560 – 1070 hPa
Altitude (operating)	-500 – 5000 m (-1640 – 16404 ft)
Vibration (operating)	
Amplitude	< 0.7 mm
Acceleration	< 2 G
Bump (transport)	< 10 G (IEC 60068-2-27)

<b>Airflow</b>	
Fan airflow	Front to sides/rear
Fan noise	
Idle condition, 1 m distance	< 30 dBSPLA
Rated power, 1 m distance	< 53 dBSPLA

**Mechanical**

<b>Enclosure</b>	
Dimensions (HxWxD)	
With mounting brackets	88 x 483 x 400 mm (3.5 x 19 x 15.7 in)
Rack unit	19 in, 2U
Ingress protection	IP30
Case	
Material	Steel
Color	RAL9017
Frame	
Material	Zamak
Color	RAL9022HR
Weight	11.8 kg (26 lb)

## 12 Ambient noise sensor (ANS)



### 12.1 Introduction

The PRA-ANS is an ambient noise sensor to monitor changing ambient noise levels for automatic adjustment of announcement or background music levels (AVC - Automatic Volume Control). This ensures the public address audio is set at a configurable level above the ambient noise in order to guarantee intelligibility of announcements, yet at a comfortable loudness.

### 12.2 Functions

#### IP-network connection

- Direct connection to the IP-network. One shielded Ethernet cable is sufficient for Power over Ethernet and data exchange.
- The ambient noise sensor communicates ambient noise level data directly to the system controller. The system controller adjusts the output level of the involved amplifier channels accordingly.
- Because only level information is exchanged and no audio data, the occupied network bandwidth for this function is minimized and there is no risk of audio eavesdropping.

#### Operation

- The ambient noise level is measured using an accurate omni-directional MEMS microphone. An integrated DSP allows for frequency response adjustments for optimum tracking of disturbing noise signals and/or minimizing the influence of non-disturbing out-of-band signals.
- Up to four sensors can operate together to cover a large area; the ambient noise level information of these sensors is combined.
- Fail-safe operation: upon failure or disconnection of the device, the announcement volume of the subscribing amplifier channels is automatically set to its maximum within the applicable control range.
- The device uses two modes for operation:
  - The sample-and-hold mode is used for live speech calls and playback of prerecorded messages. The noise level is sampled and the last level information is hold and used during the call, not affected by the sound of the call itself and its associated reverberation and echoes.
  - The tracking mode is used for background music. The noise level is tracked and the volume of the background music is continuously adapted. Because in this mode the ambient noise level is ‘polluted’ by the sound from the PA system itself, in this mode the ambient noise sensor must be mounted close to the expected noise location and away from the PA-loudspeakers to prevent volume runaway.
- Front side LEDs show the operational status.



**Installation**

- The ambient noise sensor operates in a wide temperature range and with a wide range of ambient noise levels, fitting most applications and environments.
- A back box is included for mounting on solid ceilings and walls. Cable entry from side or rear.
- Without back box, the sensor can be flush mounted in hollow walls or suspended ceilings.
- Water resistant (IP65), with and without back box, for indoor and sheltered outdoor use.
- Sealed cable gland for cable entry.
- Comes with a black and a white front cover for unobtrusive installation.

**12.3 Functional diagram**

**Functional and connection diagram**

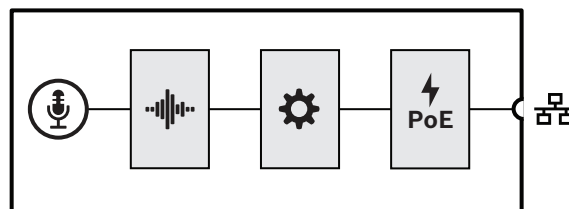

**Internal device functions**

- MEMS microphone
- Audio processing (DSP)
- Controller
- Power over Ethernet

**12.4 Indicators and connections**

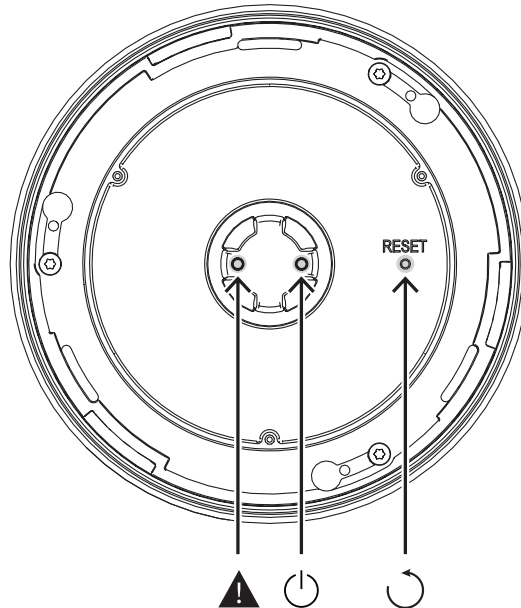

**Front-side indicator**

	Power on Device in identification mode	Green Green blinking		Device fault present	Yellow
--	---	-------------------------	--	----------------------	--------

**Front-side control (behind front cover)**

	Device reset (to factory default)	Button	
---	-----------------------------------	--------	--

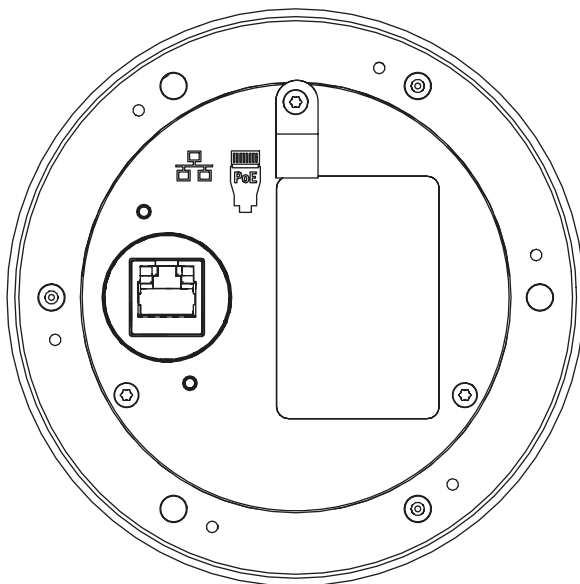

**Rear-side interconnection**

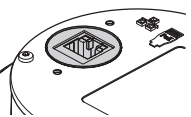
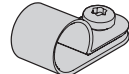
	Network port (PoE PD)		P-clamp for recommended safety cable	
--	-----------------------	---	--------------------------------------	---

## 12.5

### Installation

The Ambient noise sensor is designed to be flush- or surface-mounted on a wall or on a ceiling. The instructions in the sections that follow apply to both installation options.

#### 12.5.1

### Parts included

The box contains the following parts:

Quantity	Component
1	Sensor base unit with front gasket
1	Back box
1	Connection cap with sealing gasket
1	Cable gland, 16 mm
1	Front cover black
1	Front cover white
5	Screws 3 x 12 mm, TX10
1	Screw 3 x 8 mm, TX10
3	Wood screws 3 x 30 mm, TX10
1	Quick Installation Guide

Quantity	Component
1	Safety information

No tools or Ethernet cables are provided with the device.

**Parts check and identification**

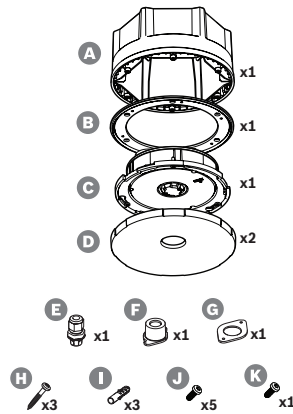

- A** Back box
- B** Sealing gasket
- C** Sensor base unit
- D** Front cover (black and white)
- E** Cable gland, 16 mm
- F** Connection cap
- G** Sealing gasket
- H** Wood screws 3 x 30 mm, TX10
- I** Plugs 5 x 25 mm
- J** Screws 3 x 12 mm, TX10
- K** Screw 3 x 8mm, TX10

**12.5.2 Power over Ethernet**

The Ambient noise sensor is a PoE Powered Device (PD) with one PoE Ethernet connection port. It provides the correct signature and classification to the power sourcing equipment (PSE), so that a PSE sources the right amount of power to a PD over the Ethernet cables. For best availability, connect the port to a PSE with battery backup power, such as the Ethernet ports 1 or 2 of the multifunction power supply PRA-MPS3. It is also possible to connect to one of the ports 1 - 8 of the Ethernet switch PRA-ES8P2S. Since the PRA-ANS only has one Ethernet port, it is impossible to make a loopthrough connection to another device.

**12.5.3 Ethernet network**

The network must be set up so that the system controller can discover and reach the ambient noise sensor for configuration. The sensor is identified by its hostname, which is printed on the product label on the rear of the device. The format of the hostname is the type number of the device without the dash, followed by a dash and then the last 6 hexadecimal digits of its MAC address. The configuration is described in the PRAESENSA Configuration manual.

Connect the noise sensor to the network using shielded Gb-Ethernet cables, preferably CAT6A F/UTP, with RJ45 connectors. To make the noise sensor water resistant and comply to IP65, pull the network cable through the supplied cable gland. In that case, install the RJ45 connector in the field.

**12.5.4 Positioning of ambient noise sensors**

The PRA-ANS ambient noise sensor measures the noise level in a zone and communicates the noise level data directly to the system controller. The system controller adjusts the output level of the involved amplifier channels accordingly. For good coverage of a zone, mount the noise sensor in the reverberant field of the most important noise sources.

Otherwise, the correlation between the measured noise level and the noise level the audience experiences will depend highly on the location of the noise source. In many cases a location near the ceiling or high on a wall is better. When AVC is also used for background music, the noise sensor should not be near the loudspeakers.

Large spaces with a relatively short reverberation time might need more than one sensor to sense the ambient noise level accurately. A zone may contain up to four noise sensors. The sensor with the highest measured noise level, after offset correction, will determine the AVC adjustment.

Refer to *AVC and the positioning of Ambient noise sensors, page 285* for details on the installation of Ambient noise sensors.

**Refer to**

- *AVC and the positioning of Ambient noise sensors, page 285*

## 12.5.5

### Water resistance

The ambient noise sensor can be installed indoors and, with some precautions, also outdoors. The sensor must be sheltered to protect it from direct sunlight to prevent overheating, but also from snow and ice to prevent that sound cannot reach the microphone. When the cable gland is used for the network cable entry, the enclosure is water resistant. A special hydrophobic mesh that is acoustically transparent, yet water resistant, protects the front side of the noise sensor, with its microphone and indicators.

- For flush mounting indoors (not water resistant), the RJ45 connector of the Ethernet cable can be inserted into the socket on the rear side of the base unit C. For flush mounting outdoors, where water resistance is important, the cable gland F, connection cap G, and sealing gasket H, are used to protect the RJ45 connection.
- For surface mounting, the back box is also needed. The sealing gasket B, between the base unit and the back box, protects against the water and helps to create a solid connection between both parts. For indoor use (not water resistant), a hole for network cable entry can be punched in the center of the back box. Optionally, a hole can be drilled in the rear side or on one of the six flat sides, depending on where the cable is coming from. For mounting outdoors, cable gland F is used on the back box (not on the base unit) to keep the water out. Detailed mounting descriptions follow in the next sections.

When the Ethernet cable enters through a correctly tightened cable gland and the front cover of the device is installed, the device is protected from low-pressure water jets from any direction. This matches protection according to IP65 and NEMA 4. Since these standards prescribe that no protecting parts of the product can be removed without tools, the replaceable twist-locked front cover of the PRA-ANS can be secured with an additional locking screw. In practice, ambient noise sensors will be mounted where the public cannot access the devices and remove the front cover, but for full compliance to the standards, use the locking screw.

### 12.5.6 Front cover and logo orientation

The sensor comes with black and a white front cover. Typically, a black front cover is also used in combination with the back box. In the case of flush mounting, only the front cover will be visible, with the white front cover allowing the sensor to be unobtrusively mounted in a white wall or ceiling.

The logo on the front cover aligns with the line through the left mounting screw, the LEDs, and the Reset-key. As such, when the sensor is mounted on a wall and the logo needs to be horizontally aligned, make sure the base unit is oriented accordingly. If the back box is used, the position of the logo always corresponds to one of corners of the hexagonal back box, not with one the flat sides.

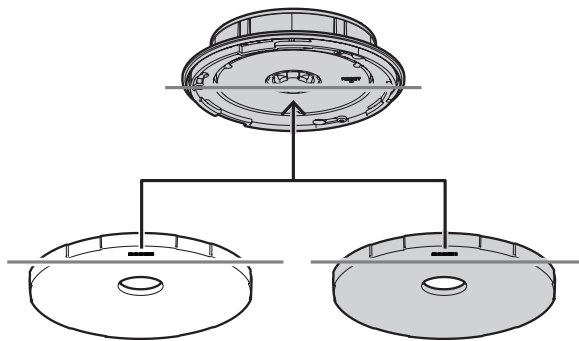

### 12.5.7 Flush mounting outdoors

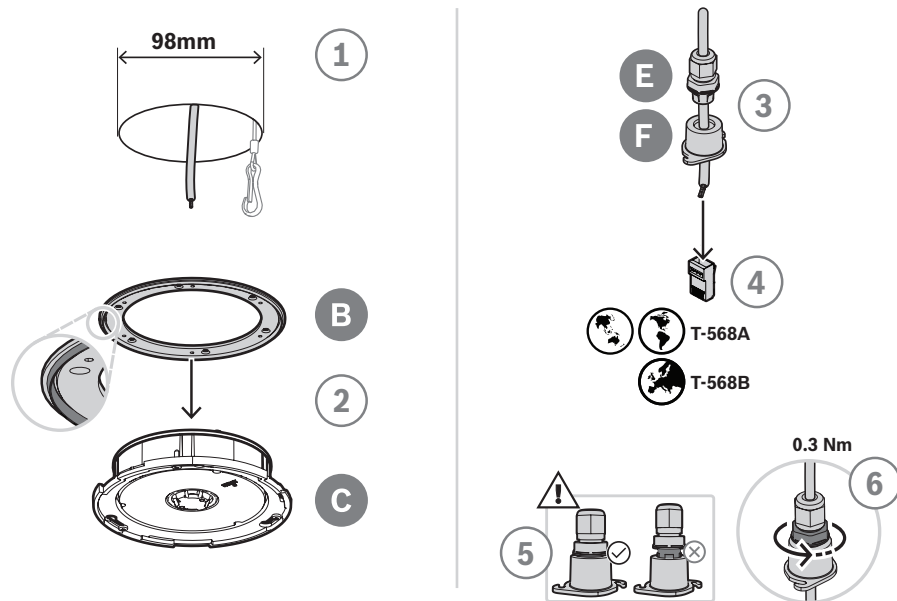

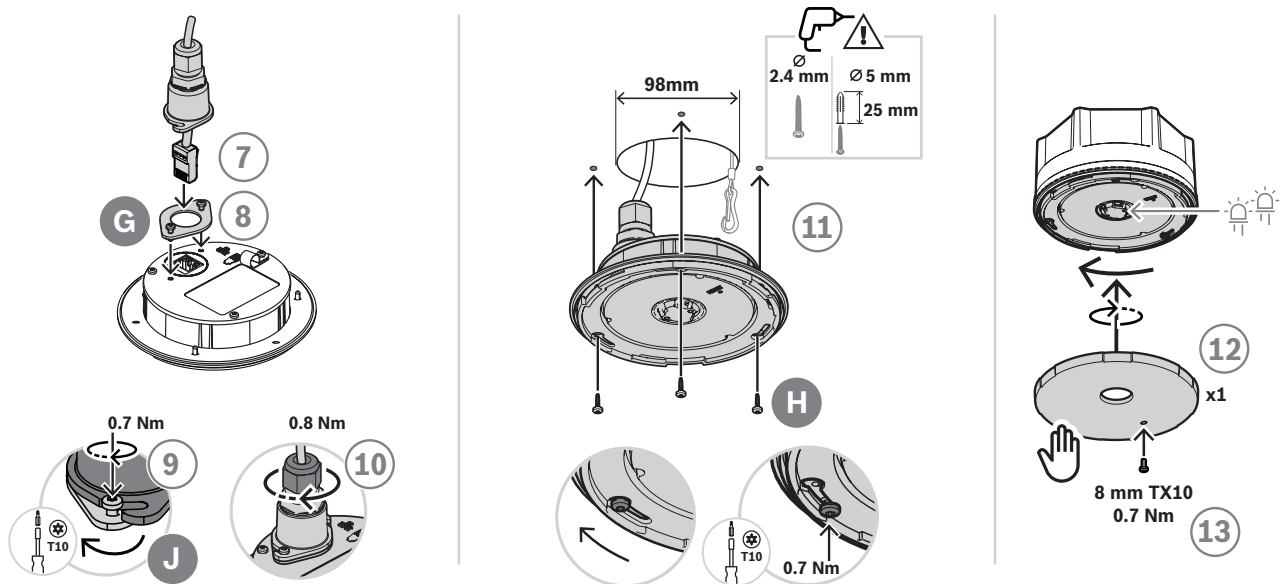

To flush mount in a hollow wall or ceiling (outdoors) do the following:

1. To prepare, make a 98 mm (3.9 in.) hole, using a hole saw, and thread an open-ended shielded Ethernet cable (preferably CAT6A F/UTP) through the hole.
2. Set the sealing gasket B on the sensor base unit C with the rim towards the front.
3. Pull the Ethernet cable through cable gland E and connection cap F.
4. Install a short RJ45 connector to the Ethernet cable.
  - Use termination standard T-568A or T-568B, according to the local standard.
5. Insert the cable gland into the connection cap and push the gland until it snaps into place.
6. Rotate the bottom large nut counter-clockwise to fix the cable gland to the connection cap with a 22 mm wrench and 0.3 Nm torque.
7. Set the sealing gasket G around the RJ45 network socket on the rear of the device.
8. Insert the RJ45 connector into the network socket.
9. Use two screws J to attach the connection cap to the device.
10. Rotate the top small nut of the cable gland clockwise to secure and seal the cable with a 19 mm wrench and 0.8 Nm torque, while holding the mounting nut with the 22 mm wrench.
  - It is recommended to attach a safety cable with split ring or spring snap to the P-clamp on the rear of the base unit to prevent the device from falling during or after installation.
11. Use the screws H into the slotted holes of the base unit C to mount the device on a flat wooden surface.
  - For hard materials like stone or concrete, use also the plugs I. For other surfaces, use appropriate fixing materials.
12. Rotate the front cover D clockwise until it clicks into place to attach it.
13. To prevent the front cover from being rotated and removed by hand, insert the 3 x 8 mm locking screw K in the front cover. The maximum torque is 0.7 Nm. The end of the screw loosely fits into one of the three blind holes in the front of the base unit.
  - This screw is mandatory for compliance to IP65 or NEMA 4 protection.

### 12.5.8 Surface mounting outdoors

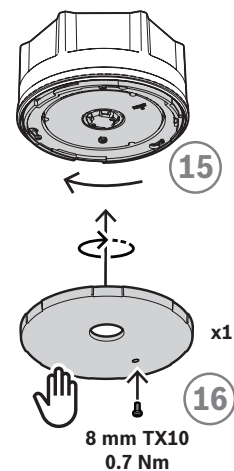
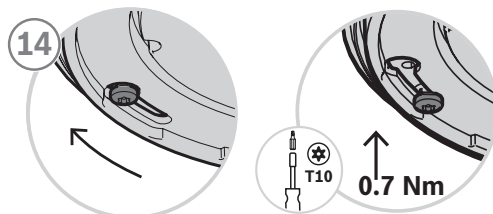
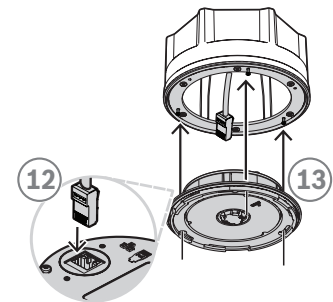
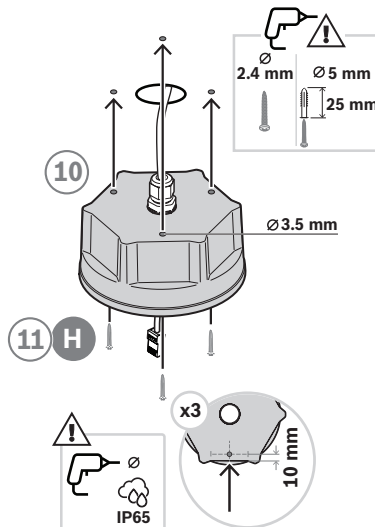
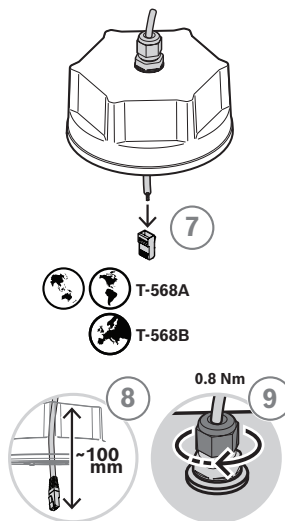
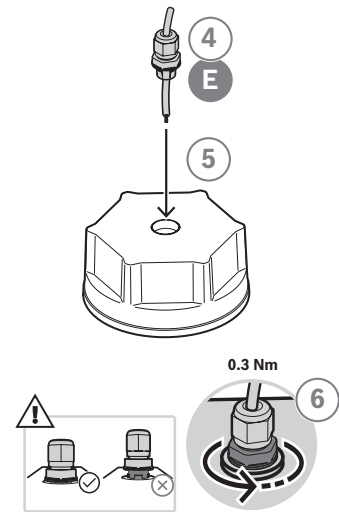
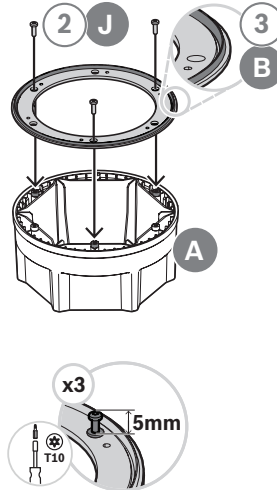
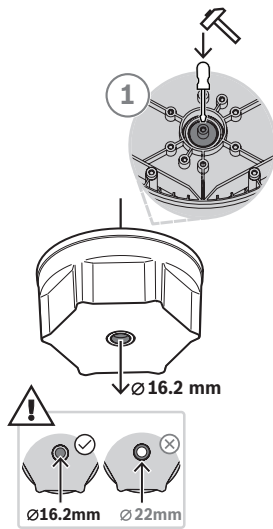

To surface mount on a wall or ceiling (outdoors), do the following:

1. Knock out the smaller center hole of the back box (diameter 16.2 mm), using a hammer and flat blade screwdriver in the inner groove.
  - If the cable entry should not be on the rear but on one of the six flat sides, drill a hole of 16.2 mm in one of the sides.
2. Screw three screws J in the back, but not completely.
3. Set the sealing gasket B over the screw heads on the back box A, with the rim towards the front.
4. Thread the Ethernet cable through cable gland E.
5. Insert the cable gland into the back box and push the gland until it snaps into place.
6. Rotate the bottom large nut counter-clockwise to fix the cable gland to the back box with a 22 mm wrench and 0.3 Nm torque.
7. Install a short RJ45 connector to the Ethernet cable.
  - Use termination standard T-568A or T-568B, according to the local standard.
8. Pull the cable 100 mm inside the back box.
9. Rotate the top small nut of the cable gland clockwise to secure and seal the cable with a 19 mm wrench and 0.8 Nm torque, while holding the mounting nut with the 22 mm wrench.
10. Drill mounting holes in the back box and use these as guide to drill matching holes in wall or ceiling.
  - If needed, take into account the alignment of the Bosch logo on the front cover before drilling the holes in a wall or the ceiling. Refer to *Front cover and logo orientation*, page 165.
11. Mount the device on a flat wooden surface using the screws H.
  - Before tightening the screws, use kit to seal the screw holes against water.
  - For hard materials like stone or concrete, use also the plugs I. For other surfaces, use appropriate fixing materials.
12. Insert the RJ45 connector into the network socket of the base unit.
13. Fasten the base unit to the back box by pushing it over the three screws already in the back box.
14. Rotate clockwise and tighten the screws.
15. Rotate the front cover D clockwise until it clicks into place to attach it.
16. To prevent the front cover from being rotated and removed by hand, insert the 3 x 8 mm locking screw K in the front cover. The maximum torque is 0.7 Nm. The end of the screw loosely fits into one of the three blind holes in the front of the base unit.
  - This screw is mandatory for compliance to IP65 or NEMA 4 protection.

### 12.5.9 Mounting indoors

For mounting indoors, follow the same steps as for mounting outdoors, except that the use of the cable gland F, connection cap G and sealing gasket H are optional. When these are not used, a pre-assembled network cable can be used.

### 12.5.10 Reset to factory default

The reset behind the front cover resets the device to its factory default settings. This function should only be used if a secured device is removed from a system to become part of another system. See *Device status and reset*, page 71.



## 12.6

### Approvals

Emergency standard certifications	
Europe	EN 54-16 (0560-CPR-182190000)
International	ISO 7240-16
Regulatory areas	
Safety	EN/IEC/CSA/UL 62368-1
Emissions	EN 55032 EN 61000-6-3 ICES-003 FCC-47 part 15B class A
Environment	EN/IEC 63000
Plenum rating	UL 2043
Railway applications	EN 50121-4

UL 62368-1 only for indoor use (UL 50E not applicable).

## 12.7

### Technical data

#### Electrical

Microphone	
Ambient noise capture range	50 – 100 dBSPL
Frequency range	50 Hz – 10 kHz
Frequency response, +/-2dB	100 Hz – 5.5 kHz
Sensitivity tolerance, pink noise 50 Hz – 10 kHz	< 2 dB
Directivity	Omni-directional
Power transfer	
Power over Ethernet	PoE IEEE 802.3af Class 1
Power consumption	1.6 W
Nominal input voltage	48 VDC
Input voltage tolerance	37 – 57 VDC
Supervision	
Controller continuity	Watchdog
Network interface	Link presence
Network interface	
Ethernet speed	100BASE-TX, 1000BASE-T
Ethernet protocol	TCP/IP
Control protocol	OMNEO (AES70)

<b>Network interface</b>	
Control data security	TLS
Ports	1
<b>Reliability</b>	
MTBF (extrapolated from calculated MTBF of PRA-AD608)	3,000,000 h
<b>Climatic conditions</b>	
Temperature, operating	-25 – 55 °C (-13 – 131 °F)
Temperature, power up	-5 – 55 °C (23 – 131 °F)
Temperature, storage and transport	-30 – 70 °C (-22 – 158 °F)
Humidity	5 – 100 %
Air pressure	560 – 1070 hPa
Altitude, operating	-500 – 5000 m (-1640 – 16404 ft)
Vibration amplitude, operating	< 0.7 mm
Vibration acceleration, operating	< 2 G
Bump (transport)	< 10 G (IEC 60068-2-27)
<b>Enclosure</b>	
Dimensions device (ØxH)	131 x 35 mm (5.2 x 1.4 in)
Dimensions device with back box (ØxH)	131 x 71 mm (5.2 x 2.8 in)
Dimensions device front cover (ØxH)	131 x 10 mm (5.2 x 0.4 in)
Ingress protection	IP65 / NEMA 4 (with mounted front cover)
Material enclosure	Plastic (PC/ABS - UL94-5VA)
Color enclosure	RAL9017
Color front cover	RAL9017 and RAL9003
Weight	0.4 kg (0.88 lb)

## 13 Control interface module (IM16C8)



### 13.1 Introduction

The PRA-IM16C8 Control interface module adds configurable and supervised control inputs, voltage-free control outputs and supervised trigger outputs to the PRAESENSA system. These contact inputs and outputs provide the easy logic connectivity of a PRAESENSA system to auxiliary equipment such as fire alarm systems, strobes, indicators, or speaker relays.

The PRA-IM16C8 enclosure allows for DIN rail installation near to the auxiliary equipment for short interconnections. The module only requires a connection to an OMNEO IP-network with Power over Ethernet (PoE) for communication and for power supply combined.

### 13.2 Functions

#### IP-network connection

- Direct connection to the IP-network. One shielded Ethernet cable is sufficient for Power over Ethernet and data exchange.
- Connect a second shielded Ethernet cable for dual redundancy of network and of power connection.
- Integrated network switch with two OMNEO ports allows for loop-through connections to adjacent devices that provide PoE. Rapid Spanning Tree Protocol (RSTP) is supported to enable recovery from failing network links.

#### General-purpose control inputs and outputs

- Sixteen control inputs receive contact closure information from external systems with configurable connection supervision.
- Eight relay contacts, voltage-free and with single-pole and double-throw (SPDT), to activate external devices.
- Two supervised 12 V trigger outputs to trigger a booster for Notification Appliance Circuits (NAC), such as strobes and horns. Supervision happens through polarity reversal in combination with an end-of-line resistor.
- Control input and output functions are configurable in the software.
- LEDs indicate the operational status and the fault status of all inputs and outputs.

**Installation**

- The compact enclosure for DIN-rail mounting allows for easy installation in most applications and environments.
- Pluggable spring-cage terminal blocks for easy wire connection.
- Connection supervision of control inputs, trigger outputs and network connections, including ground short supervision.

**13.3 Functional diagram**

**Functional and connection diagram**

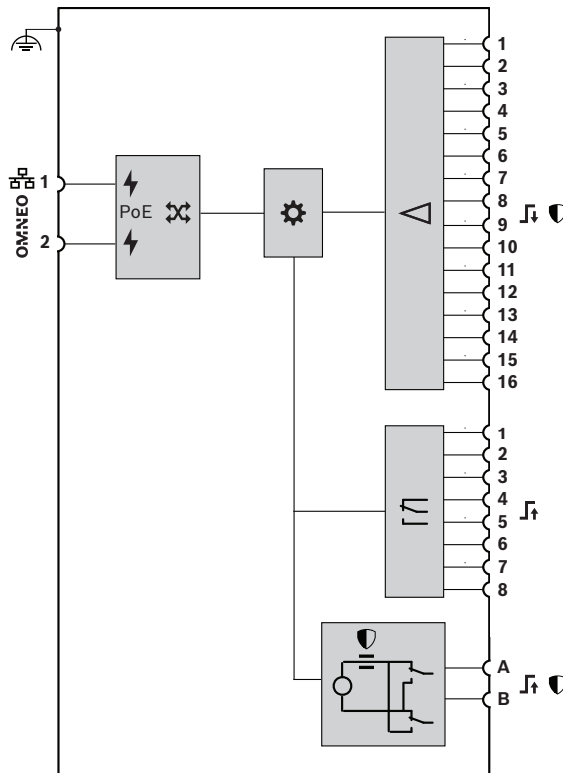

**Internal device functions**

- Power over Ethernet
- Controller
- OMNEO network switch
- Control input processor
- Supervision
- Control output relay
- Supervision current detector
- Current limited voltage source

### 13.4 Indicators and connections

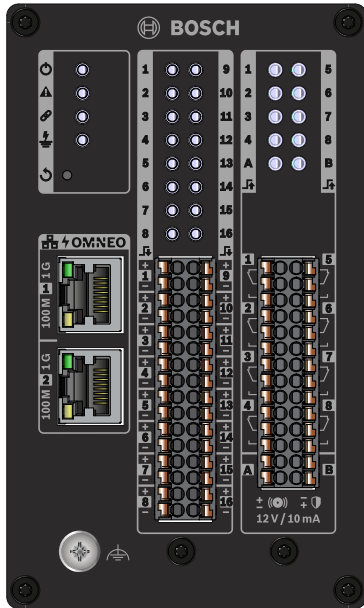





Front panel indicators and controls

	Power on	Green		100 Mbps network 1Gbps network	Yellow blinking Green blinking
	Device fault present	Yellow		Input contact closed 1-16 Input connection fault 1-16	Green Yellow
	Network link to system controller present Network link lost	Green Yellow		Output contact activated 1-8 Output contact activated A-B Output connection fault A-B	Green Green Yellow
	Ground fault present	Yellow			
	Device reset to factory default (> 10 seconds)	Button		Identification mode / Indicator test (1 second)	All LEDs blink

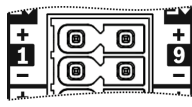
Front panel connections

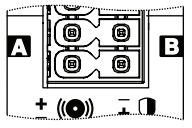
	Network port 1-2 (PoE PD)			Control output 1-8	
--	---------------------------	--	--	--------------------	--

	Control input 1-16			Trigger output A-B	
	Chassis ground				

## 13.5 Installation

Install the interface module vertically on a 35 mm DIN-rail, complying to the EN 60715 standard. Connect it anywhere within the PRAESENSA system. Refer to *System introduction*, page 19.

### 13.5.1 Parts included

The box contains the following parts:

Quantity	Component
1	Control interface module, 16x8
1	DIN rail mounting bracket (pre-assembled)
1	Set of connectors
34	Supervision resistors, 10 kohm
1	Safety and security information booklet
1	Quick installation guide

No tools or Ethernet cables are provided with the device.

#### Parts check and identification

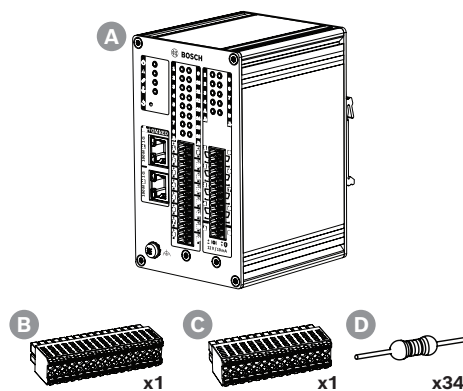

- A** Control interface module, 16x8
- B** Cable connector, 32-pole
- C** Cable connector, 28-pole
- D** Supervision resistors

### 13.5.2 DIN rail installation

#### To install the device

Install the interface module vertically on a 35 mm DIN rail, complying to the EN 60715 standard.

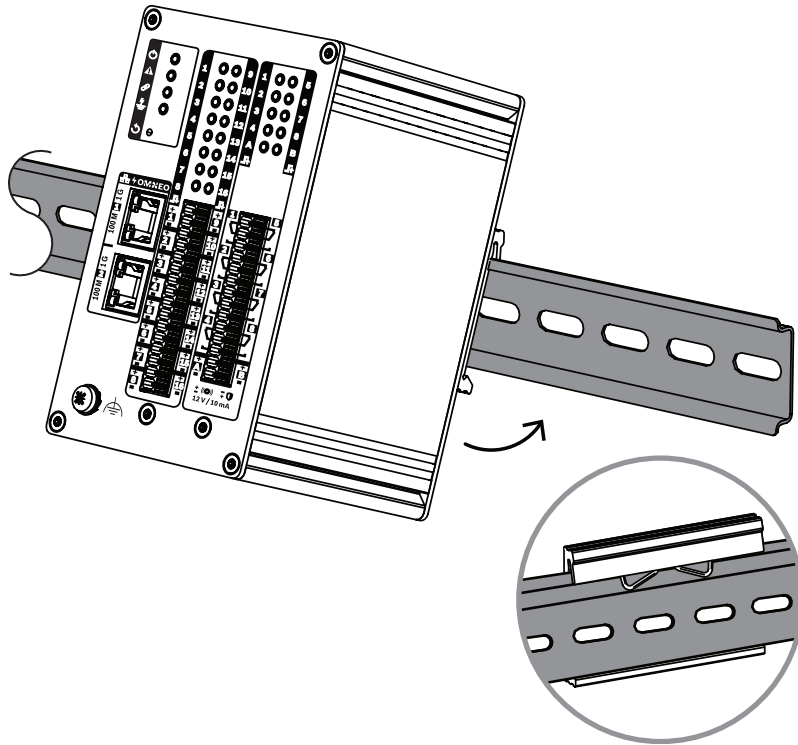

1. Tilt the device upwards.
2. Mount the device on the DIN rail.
3. Push the module downwards until it stops.
4. Push against the bottom of the front side to lock the device on the rail.
5. Shake the device slightly to make sure that it is secure.

**To uninstall the device**

1. Push the module downwards until it stops.
2. Tilt the device upwards.
3. Pull the device from the rail.

**13.5.3****Safety ground**

Connect the functional ground screw to safety ground.

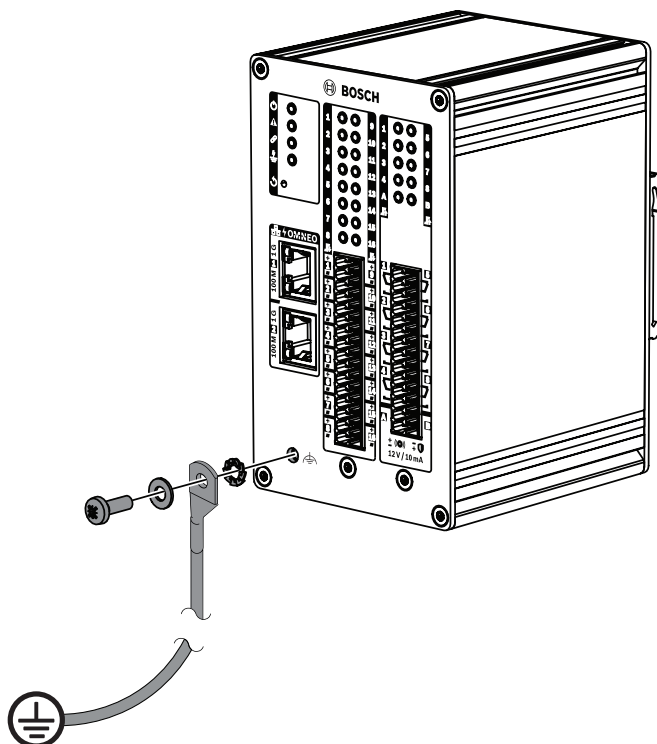

Use the functional ground screw on the front panel as a wire connection to the rack frame. Ground the rack frame to safety ground to protect against electrical shocks. Without the safety ground connection, ground shorts and leakage currents are not detected for interconnection wires that touch the ground.

The ground connection is also required to comply with:

- the EMC requirements of the EN 50130-4 for Voice Alarm systems
- EN 50121-4 for Railways applications
- EN 55024 for IT equipment and EN 55035 for Multimedia equipment regarding the immunity to slow surges.



### 13.5.4 Power over Ethernet

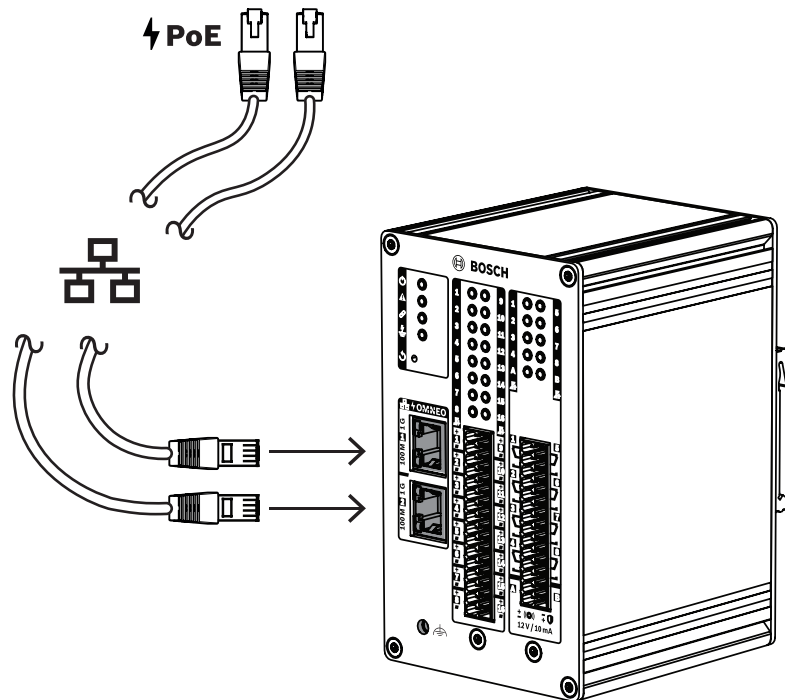

The control interface module has two Ethernet connection ports with a built-in Ethernet switch, supporting RSTP. The interface module is a PoE Powered Device (PD). The module provides the correct signature and classification to the power sourcing equipment (PSE). As such, it enables a PSE to source the right amount of power to a PD over the Ethernet cables. Although it is sufficient to provide PoE power to only one port, both Ethernet ports receive PoE power for cable redundancy and for supply redundancy.

Connect each port to a different, independent PSE, such as ports 1 and 2 of the PRA-MPS3 or ports 1-8 of the PRA-ES8P2S. In case one of the connections fail or one of the PSE sources fail, the interface module is not affected. With both connections to the same PSE, connection redundancy is available, but PSE redundancy is not.

You can loop through the ports of the module to another PRAESENSA device, but connect at least one port to a PSE to power the module. Connection redundancy is not possible with only one port connected to a PSE.

The interface module ports cannot supply PoE power to subsequent devices, such as another interface module.

To connect the control interface module, use one or two shielded Gb-Ethernet cables (preferably CAT6A F/UTP) with RJ45 connectors to connect the module to a PSE port, with PoE enabled.

### 13.5.5 Connection to the system controller

Set up the network for the system controller to discover and to reach the control interface module for configuration. The module is identified by its hostname, which is printed on the product label on the side of the device. The format of the hostname is:

- The type number of the device without the "M" and the dash: PRAI16C8
- **Note:** This is an exception compared to the other PRAESENSA products.
- A dash.
- The last six hexadecimal digits of the hostname MAC address.

The configuration is described in the PRAESENSA configuration manual.

### 13.5.6 Control inputs 1-16

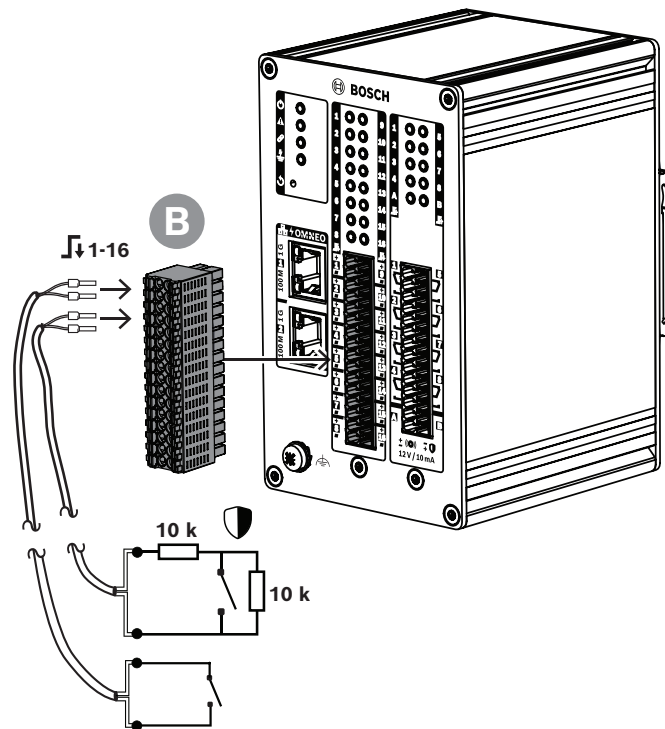

The control interface module provides 16 control inputs on a 32-pole connector. You can configure the control inputs independently for various actions. The control inputs can be activated on the closing or the opening of a contact, with or without interconnection supervision. Refer to the PRAESENSA configuration manual for all options.

If you do not configure interconnection supervision, use a switch or a relay output from another system for activation.

If you use a control input to activate emergency calls, interconnection supervision is needed to generate a fault warning in case of an open or shorted circuit. In that case:

1. Connect a resistor with a value of 10 kohm (0.25 W) between the cable and the switch.
2. Connect another resistor with the same value across the switch

The control input sees 20 kohm for an open contact and 10 kohm for a closed contact. In case of a cable interruption, the control input sees a very high resistance. In case of a cable short-circuit, the control input sees a very low resistance. A very high or very low resistance will be interpreted as a fault condition.

#### How to connect, with and without supervision

Use a 2-wire cable and the 32-pole terminal plug (B) delivered with the device.

1. Insert the near end wires of the cable into the appropriate slots of the terminal plug.
  - The connector uses time saving push-in, spring cage connections for a defined contact force that ensures a stable contact over the long term. This connector is optimized for tight installation situations, because the spring lever and wire slot are both on the front side.
2. **Without supervision:** Connect the other side of the cable to the activation switch or voltage free relay contact.

3. **With supervision:** connect the other side of the cable to the combination of activation switch and two 10 kohm supervision resistors. One resistor is in series with the switch. The other resistor is in parallel with the switch.



**Notice!**

In the PRA-IM16C8, the ‘-’ connections of all control inputs are directly connected to internal ground. This connection allows the ‘-’ connections to be shared between inputs of the same device.



**Notice!**

For the PRA-IM16C8 control inputs, a maximum voltage of 24 V referred to protective ground will not cause a current to flow, as the device is floating. However, for correct ground fault detection, the control inputs of PRA-IM16C8 cannot be electrically connected to the inputs of another PRA-IM16C8. Such interconnection affects the threshold for ground fault detection.

**13.5.7 Control outputs 1-8**

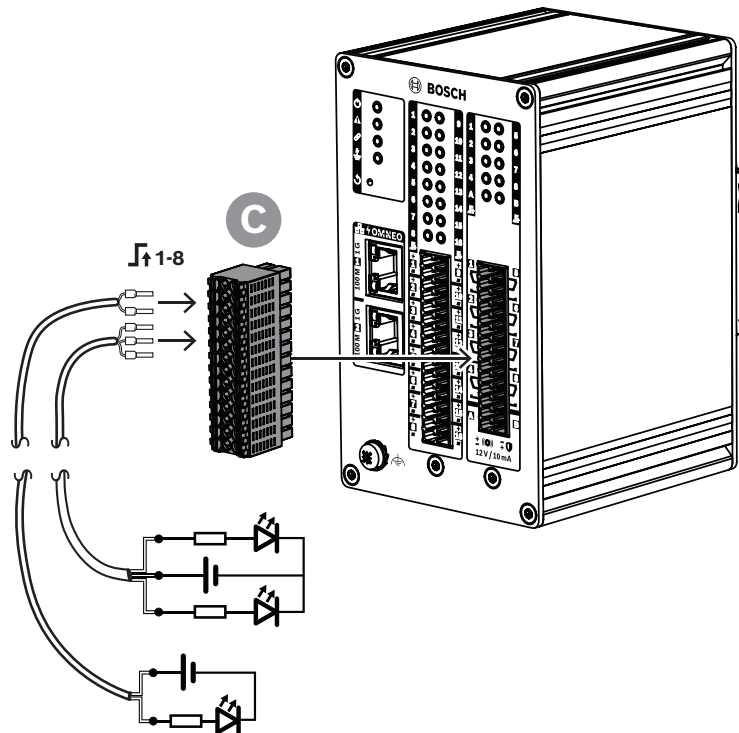

The control interface module provides eight control outputs with a Single Pole Double Throw (SPDT) relay for each output, with a Normally Closed (NC) and a Normally Open (NO) contact. The control outputs can be configured independently for various actions. Do not exceed the maximum contact rating.

**How to connect**

Use a 2-wire or 3-wire cable and the 28-pole terminal plug (C), delivered with the device.

1. Insert the near end wires of the cable into the appropriate slots of terminal plug.
2. Connect the other side of the cable to the application to be activated.

### 13.5.8 Trigger outputs A-B

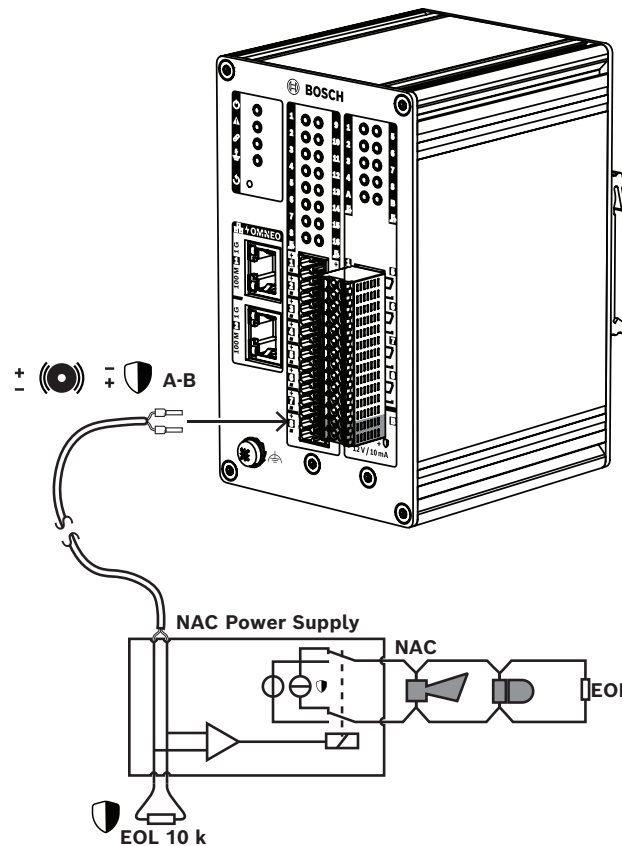

The control interface module provides two supervised trigger outputs, A and B, to activate strobes and bells or horns that are connected to a Notification Appliance Circuit (NAC) power supply or NAC booster. A NAC is typically used in North America for Mass Notification.

The NAC starts at the NAC power supply and goes out to the notification devices in the building. It is a 2-wire circuit with loop-through connection of horns and strobes, typically terminated by an end-of-line resistor for circuit supervision. There are two conditions for a working NAC:

- Supervision (standby). When the NAC is in standby condition, the relay connects NAC supervision circuitry inside the NAC power supply to the NAC circuit with end-of line resistor. The supervision circuitry detects the presence of the end-of-line resistor and in this way monitors the integrity of the interconnection for interruptions and short circuits.
- Alarm. When the panel is in alarm condition, the relay connects power from the NAC power supply to the NAC circuit with the notification devices.

A relay inside the NAC power supply selects between these two conditions.

Many NAC power supplies provide synchronization signals on the outputs to the notification devices. This means that the strobes flash at the same time as the others in the system. The tones from sounders are synchronized too. Several different, proprietary, types of synchronization signals are in use. NAC power supplies support different synchronization methods.

The control interface module uses a similar supervision method for the connections between the module and the NAC power supply. The control interface module does not supply power to the NAC. Instead, the module triggers the NAC power supply to do so. The two outputs A and B can be used to activate two different NACs connected to a NAC power supply. Supervision is performed by sourcing a negative output voltage and measuring the current through each 10 kohm end-of line resistor. When an output is activated, it sources a maximum 12 V / 10 mA positive to trigger an input of the NAC power supply.

### 13.5.9 Effects of the interconnection faults

The control inputs 1-16 and the control outputs A and B can be supervised to detect interconnections faults, both interruptions and short circuits. A detected fault affects the behavior of the associated input or output.

- Control inputs 1-16 with a connection supervision fault present do not act on input contact changes unless the change creates a valid input state (8 – 12 kohm or 18 – 22 kohm contact resistance).
- An emergency call that was started by an activated input proceeds when a connection fault occurs for that input. A lower priority action that starts by an activated input is aborted when a connection fault occurs for that input.
- Control outputs A and B can still be activated when a connection fault is present to activate as many Notification Appliances as possible.
- If a control output A or B is already activated when a fault occurs, no fault is reported for that output. The PRA-IM16C8 is not able to supervise an activated output.

### 13.5.10 Reset to factory default

The reset switch resets the device to its factory default settings. Only use this functions if a secured device is removed from a system to become part of another system. Refer to *Device status and reset, page 71*.

#### Refer to

- *Device status and reset, page 71*

### 13.5.11 Device recovery

When PRAESENSA devices are unable to upgrade, the internal firmware forces them into bootloader mode for recovery. The PRA-IM16C8 is an exception, because it does not contain a bootloader. When you download a wrong firmware version to the control interface module, the device locks up and requires a special recovery procedure before it can accept a correct firmware version. For instance, this happens when the device is used in a system running software version V1.81. The minimum software version for the PRA-IM16C8 is version V1.91.

A locked device can be recovered as follows:

1. Power off the device by disconnecting the network cables with PoE.
2. Press and hold the **Reset to factory default** button.
3. Power on the device by connecting a network cable with PoE.
4. Keep the button pressed for at least another second.
5. Release the button
  - The device resets and is functional again.

Although you use the same button for the recovery of a device as for resetting a device to its factory default (*Reset to factory default, page 181*), these two actions are unrelated and serve different goals.

**Refer to**

- *Reset to factory default, page 181*

**13.6****Approvals**

<b>Emergency standard certifications</b>	
Europe	EN 54-16 (0560-CPR-182190000)
International	ISO 7240-16
<b>Regulatory areas</b>	
Safety	IEC/CSA/UL 62368-1
Immunity	EN 55035 EN 50130-4
Emissions	EN 55032 EN 61000-6-3 ICES-003 FCC-47 part 15B class A
Environment	EN/IEC 63000

**13.7****Technical data****Electrical**

<b>Power transfer</b>	
Power over Ethernet	
Nominal DC input voltage	48 V
Standard	IEEE 802.3af Class 2
Input voltage tolerance	37 – 57 VDC
Power consumption	4.5 W

<b>Network interface</b>	
Ethernet	100BASE-TX; 1000BASE-T
Protocol	TCP/IP
Redundancy	RSTP
Control protocol	OMNEO (OCA/AES70)
Control data security	TLS
Ports	2

<b>Control interface</b>	
Control input contacts 1-16	
Principle	Contact closure
Galvanic isolation	No
Supervision	Resistance measurement

<b>Control interface</b>	
Contact closed	8 – 12 kohm
Contact open	18 – 22 kohm
Cable fault detection	<2.5 kohm / >50 kohm
Minimum hold time	100 ms
Maximum voltage to ground	24 V
Control output contacts 1-8	
Principle	Contact switch over (Relay SPDT)
Galvanic isolation	Yes
Maximum contact voltage	24 VDC
Maximum contact current	1 A
Maximum voltage to ground	500 V
Trigger output contacts A-B	
Principle	Bipolar control voltage
Galvanic isolation	No
Output voltage	11 – 12 V
Output current	15 mA maximum

<b>Supervision</b>	
Control input connections	Open / short
Trigger output connections	Open / short
Ground fault	<50 kohm leakage
Controller continuity	Watchdog
Network interface	Link presence
PoE 1-2	Voltage

<b>Reliability</b>	
MTBF (Telcordia SR-332 Issue 3)	2,200,000 h

**Environmental**

Operating temperature	-5 – 50 °C
Operating temperature	23 – 122 °F
Storage and transport temperature	-30 – 70 °C
Storage and transport temperature	-22 – 158 °F
Humidity (non-condensing)	5 – 95 %
Air pressure	560 – 1070 hPa
Operating altitude	-500 – 5000 m

Operating altitude	-1640 – 16404 ft
Operating vibration	
Amplitude	< 0.35 mm
Acceleration	< 2 G
Bump (transport)	< 10 G (IEC 60068-2-27)

### Mechanical

<b>Enclosure</b>	
Dimensions (W x H x D) (mm)	78 x 131 x 100 mm
Dimensions (W x H x D) (in)	3.1 x 5.2 x 4.0 in
Ingress protection	IP30
Body	
Material	Aluminum
Color	RAL9017
Weight (kg)	0.57 kg
Weight (lb)	1.3 lb



## 14 LCD call station (CSLD, CSLW)



PRA-CSLD

PRA-CSLW

### 14.1 Introduction

This call station for use in PRAESENSA Public Address and Voice Alarm systems is easy to install and intuitive to operate because of its touch screen LCD, providing clear user feedback about setting up a call and monitoring its progress, or controlling back ground music.

The call station allows for positioning without much effort, because it only requires a connection to an OMNEO IP-network with Power over Ethernet (PoE) for communication and power supply combined. The housing is fit for surface mounting and flush mounting. It can be configured for use as business call station, but also as emergency call station. The stylish design incorporates a supervised microphone, an internal monitor loudspeaker and a socket to insert a local audio source for background music.

The 4.3" high-resolution full-color capacitive touch screen gives the operator optimum control and feedback at all times.

Add up to four PRA-CSE call station extensions for zone selection and other functions. Without extensions the call station can only be used with a pre-configured zone selection.

### 14.2 Functions

- Direct connection to the IP-network. One shielded Ethernet cable is sufficient for Power over Ethernet and data exchange.
- Connect a second shielded Ethernet cable for dual redundancy of network and of power connection.

#### Business operation

- Full color 4.3" capacitive touch screen with intuitive function menu navigation provides guidance and feedback during the process of live announcements, pre-recorded messages and music control. Successful broadcast of announcements/messages and changes to the background music settings are clearly indicated.
- Press-to-talk button gives tactile feedback and is recessed to prevent accidental use.
- Built-in monitor loudspeaker with volume control.

- Local audio line input (with stereo to mono conversion) for connecting an external audio source. The audio channel will be available on the network and can be played in any loudspeaker zone.
- Connection of up to four PRA-CSE extensions, each with twelve buttons. The buttons can be configured for various functions, but they are especially useful for zone selection, giving a clear overview of accessible zones and the LED indicators for each button show the status of the respective zone (like being selected, occupied or at fault).
- A User number and PIN code can protect the device in public places against unauthorized access.
- If the call station is not used for a while, it will switch to sleep mode to save energy. It will immediately wake up when the screen, or a button, is touched.

## 14.3 Functional diagram

### Functional and connection diagram

#### PRA-CSLD

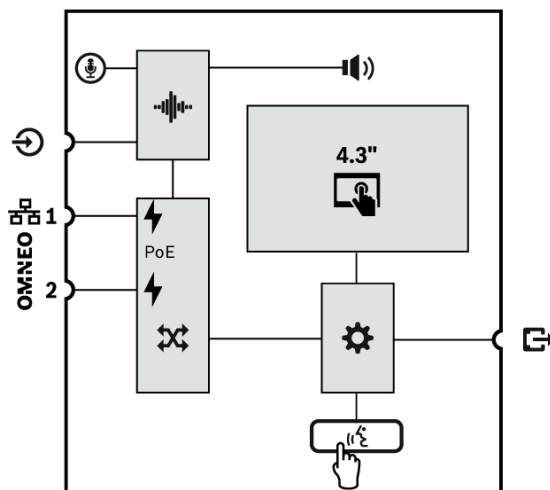

### Internal device functions

- Fixed microphone on a flexible stem
- Internal monitor loudspeaker
- Audio processing (DSP)
- Power over Ethernet
- OMNEO network switch
- Controller
- Press-To-Talk button

#### PRA-CSLW

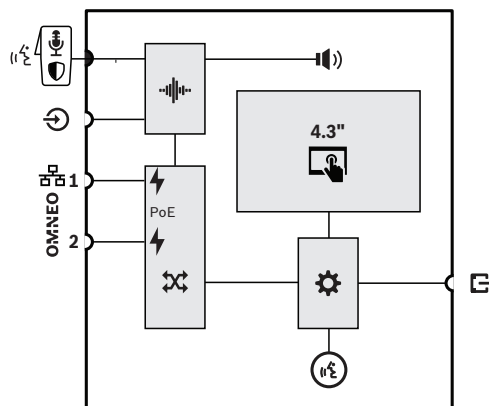

- Detachable fist microphone with Press-To-Talk or Start/Stop switch
- Call status LED ring





## 14.4 Indicators and connections



PRA-CSLD



PRA-CSLW

### Top side indicators

	Power on Device in identification mode	Green Green blinking		System fault present	Yellow
	PRA-CSLD Status business call Microphone active Chime/message active  Status emergency call Microphone active Alarm tone/message active	Green Green blinking  Red Red blinking		4.3" full-color capacitive touch screen	LCD
	PRA-CSLW Status business call Microphone active Chime/message active  Status emergency call Microphone active Alarm tone/message active	Green Green blinking  Red Red blinking		Identification mode / Indicator test	All LEDs blink

For use in dark control rooms, like the bridge of a ship at night, the brightness of the LCD backlight and the status LEDs can be adjusted in four levels, from dark to bright with two steps in between. This applies from hardware version V1.01 onwards.



### Top side controls

	Press-To-Talk	Button		4.3" full-color capacitive touch screen	LCD
---	---------------	--------	---	---	-----





	Press-To-Talk	Switch			
---	---------------	--------	--	--	--

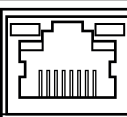

**Bottom side indicators and controls**

	100 Mbps network 1-2 1 Gbps network1-2	Yellow Green		Device reset (to factory default)	Button
---	---	-----------------	---	-----------------------------------	--------

**Bottom side and side interconnections**

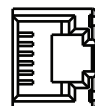
	Network port 1-2 (PoE PD)			Local source audio line input	
		PRA-CSE interconnection			

**14.5**

**Installation**

The call station is designed to be installed on a desktop (PRA-CSLD) or on a wall (PRA-CSLW) and in combination with one or more call station extensions (PRA-CSE). The following installation instructions apply to both products.



**Notice!**

In case of flush mounting, the rear or bottom must be vented. It is used as a heatsink.

**14.5.1**

**Parts included**

The box contains the following parts:

**PRA-CSLD**

Quantity	Component
1	Desktop LCD call station

Quantity	Component
1	Bracket (attached to bottom)
1	Connector cover (attached to bottom)
1	Quick installation guide
1	Safety and security information

**PRA-CSLW**

Quantity	Component
1	Wallmount LCD call station
1	Bracket (attached to bottom)
1	Connector cover (attached to bottom)
1	Microphone with coiled cable and connector
1	Microphone bracket
1	P-clip for microphone cable
1	Quick installation guide
1	Safety and security information

No tools or Ethernet cables are provided with the device.

**Parts check and identification**

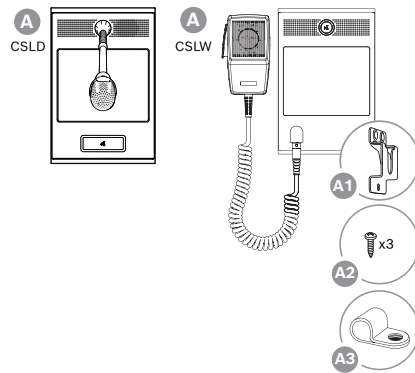

- A** Desktop/wallmount LCD call station
- A1** Microphone holder
- A2** Microphone screws for holder
- A3** P-clip for microphone cable

**14.5.2**

**Interconnection call station / extension**

Add up to four PRA-CSE call station extensions for zone selection and other functions. Without extensions the call station can only be used with a pre-configured zone selection. A call station (A) will automatically assign a connected extension (B) to itself and number the extensions in succession. Manual addressing is not needed and not possible. The system will supervise that a configured extension remains connected to its call station. Refer to: *Extension connected to a call station, page 203.*

**14.5.3**

**Power over Ethernet**

The call station has two Ethernet connection ports with a built-in Ethernet switch, supporting RSTP. The call station is a PoE Powered Device (PD). It provides the correct signature and classification to power sourcing equipment (PSE), so that a PSE sources the right amount of power to a PD over the Ethernet cables. Although it is sufficient to provide

PoE power to only one port, both Ethernet ports take PoE power for cable redundancy and supply redundancy. For best availability it is advised to connect each port to a different, independent PSE, such as a PRA-MPS3 multifunction power supply (ports 1 and 2) or a PRA-ES8P2S Ethernet switch (ports 1-8). In case one of the connections fail, or one of the PSE sources fail, the operation of the call station is not affected. With both connections to the same PSE, there is still connection redundancy but no PSE redundancy.

The ports of the call station can be looped through to another PRAESENSA device, but at least one port must be connected to a PSE to power the call station and its extensions. With only one port connected to a PSE, there is no connection redundancy.

The call station ports cannot source PoE power to subsequent devices, such as another call station.

To connect the call station, follow the procedure below:

1. Remove the cable cover at the bottom of the call station using a TX10 screwdriver.
  - Get access to the two screws via the holes in the table stand bracket.
2. Use one or two shielded Gb-Ethernet cables (preferably CAT6A F/UTP) with RJ45 connectors to connect the call station to a PSE port, with PoE enabled.
3. Put back the cable cover with the two TX10 screws.

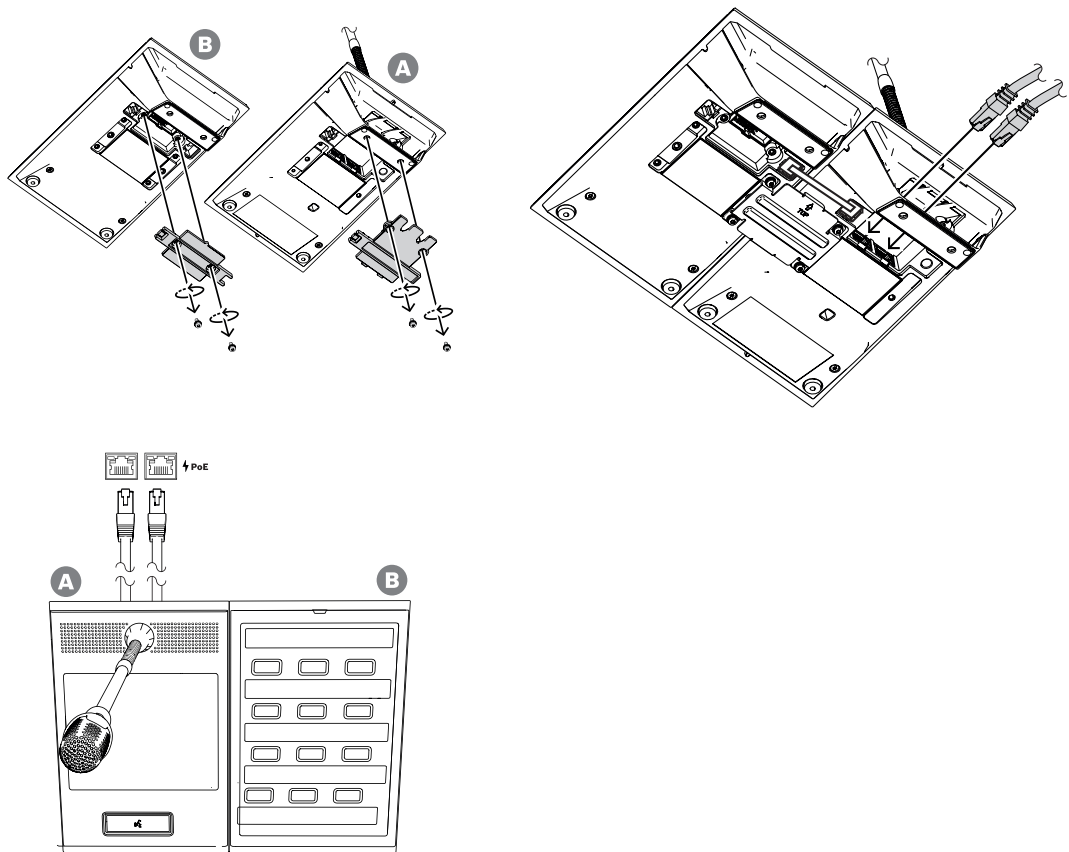

#### 14.5.4

#### Ethernet network

The network must be set up in such a way that the call station can be discovered and reached by the system controller. Configuration of the call station and its extensions is done via the system controller. For configuration, the call station is identified by its hostname,

which is printed on the product label on the bottom of the device. The format of the hostname is the type number of the device without the dash, followed by a dash and then the last 6 hexadecimal digits of its MAC-address.

Configuration is described in the PRAESENSA configuration manual.

## 14.5.5

### Line input

On the left side of the call station is a 3.5 mm stereo socket. This is an input for a background music source, such as a dedicated audio player, smartphone or PC. The stereo signal is converted to mono for further distribution in the system. This input needs to be configured in the system for this function, to link it to a background music channel that is available for playback in one or more system zones. This input is not supervised, unplugging the cable to the audio player will not be reported as a fault.

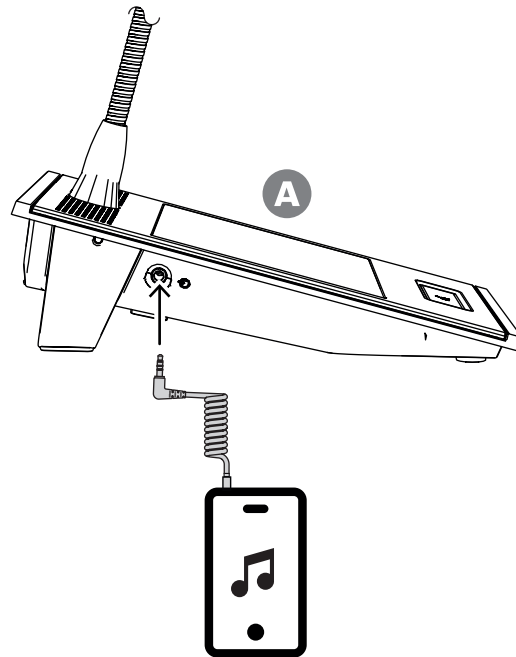

#### Notice!

When music is played from a PC that is connected to a grounded mains supply, there is a risk of hum being inserted into the music input of the call station. This is caused by unequal ground potentials of the different mains supplies. Use a cable with integrated transformers for ground loop isolation to prevent such hum. See picture below of an example ground loop isolator cable.



#### Notice!

For compliance to DNV GL type approval, the line input must not be used. By connecting a cable to this input the radiated emission of the device would exceed the limit for the maritime radio band.



### 14.5.6 Call station microphone frequency response

#### PRA-CSLW

The typical frequency response of the PRA-CSLW call station microphone is shown in the next diagram (black), together with the boundaries according to EN 54-16, clause 13.12.3 (red). The frequency response has been measured at a distance of 10 cm (4 in) with 1/6<sup>th</sup> octave smoothing. It rolls off rapidly below 1 kHz to cancel environmental noise. But this might result in a lack of body of the voice sound.

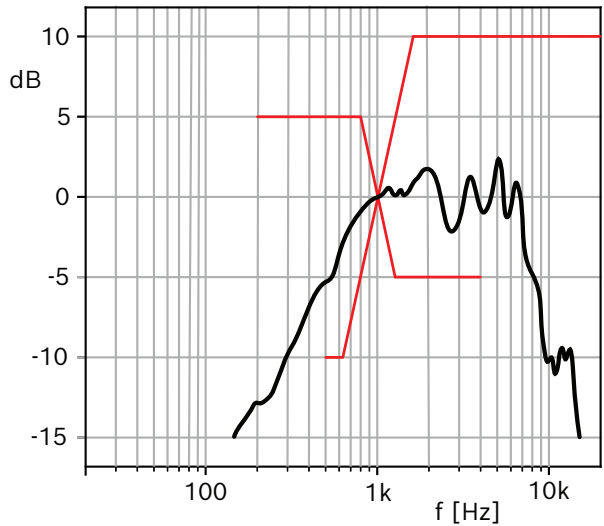

In environments that are not extremely noisy, the sound can be improved by applying parametric equalization on this call station, lifting the frequency band between 300 Hz and 1 kHz as shown in the next diagram. This makes the frequency response more flat between 300 Hz and 6 kHz. A low-cut filter below 300 Hz helps to improve speech intelligibility. See the PRAESENSA configuration manual for details on how to get to the audio options in the configuration.

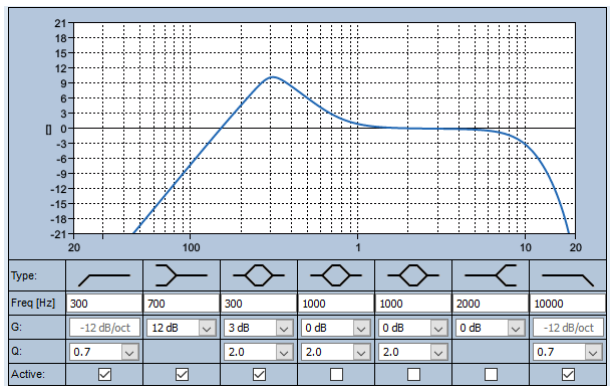

#### PRA-CSLD

The typical frequency response of the PRA-CSLD call station microphone is shown in the next diagram (black), together with the boundaries according to EN 54-16, clause 13.12.3 (red). The frequency response has been measured at a distance of 20 cm (8 in) with 1/6<sup>th</sup> octave smoothing.

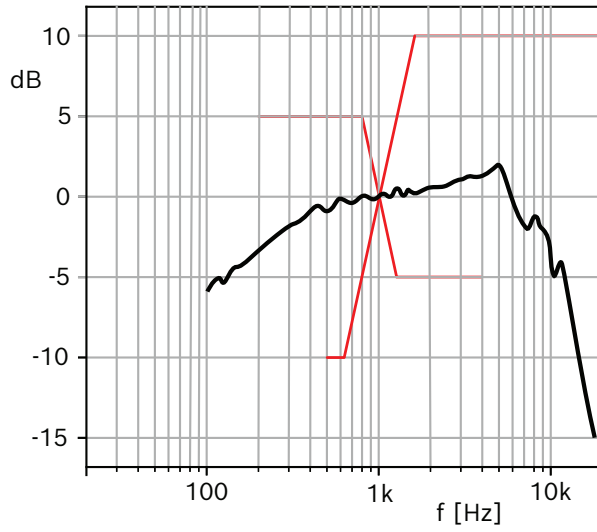

### 14.5.7 Microphone connection diagram

The microphone of the PRA-CSLW is detachable and uses a lockable 6-pin mini XLR connector with the following pin assignments.

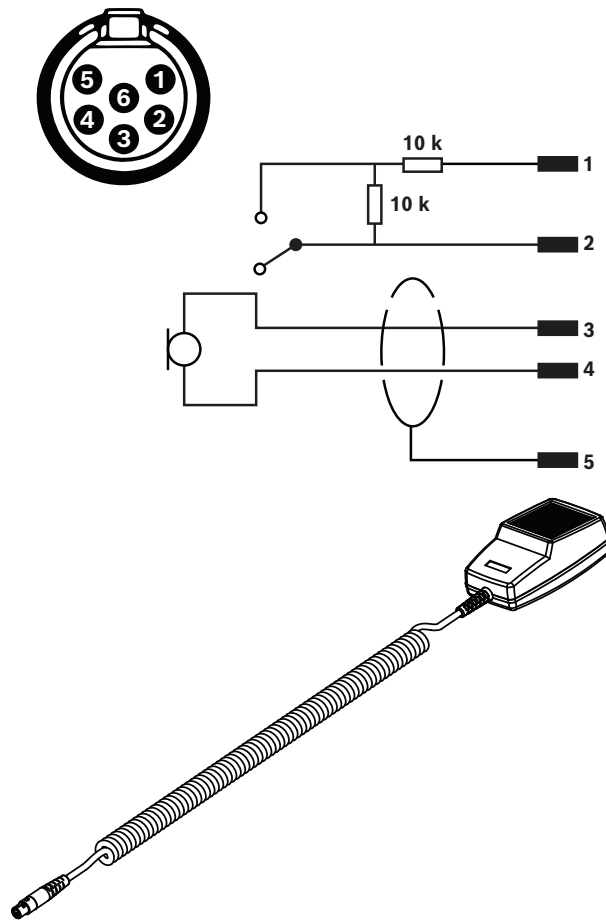

## 14.5.8

### Mounting

The call station and call station extension enclosures have two rear M4-threaded inserts of 5 mm depth to facilitate fixing the devices to a plate for horizontal or vertical mounting on a desktop or against a wall. Use M4 bolts (metric 4 mm thread), having a length of the thickness of the mounting plate or bar plus an additional 4-5 mm. Or use M4 extension bolts (hexagonal spacer) to create more distance between the device and the mounting plate.

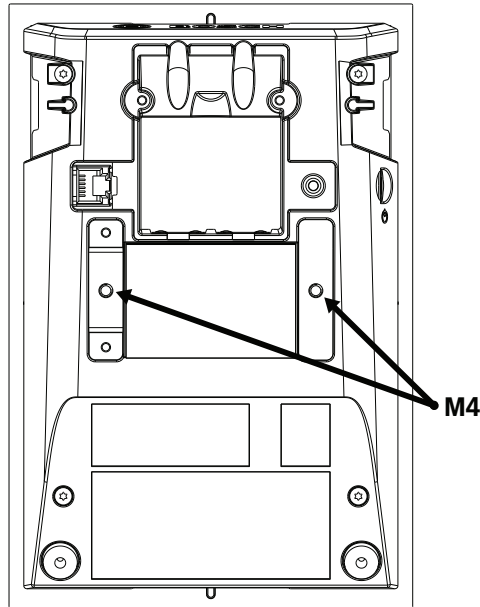

For mounting against a wall, the mounting plate must be firmly attached to the wall using screws and wall plugs. For stone walls use screws of 4 mm diameter and 40 mm length with matching plugs; for hollow walls use hollow wall or dry wall anchors with matching screws, approximately 5 mm diameter and 50 mm length.

For flush mounting, the call station and extension can be sunk into a rectangular cavity of 182 mm x 120 mm. Center distance is 130 mm between the cavities of call station and extensions. On the front and rear sides, just below the rim of the top cover, are adapter slots (size 50 mm x 3 mm, depth 3 mm) to accept a lip for positioning. These slots can also be used for fixing the call station and extensions.

You can remove the desktop stand of the call station and extensions. Insert a Torx TX10 screwdriver into the slot of the stand, just below the rim of the top cover. Use to pry off the desktop stand on one side, and then on the other side. Be careful not to damage the rim of the top cover. Use a piece of metal, for instance a metal ruler, between the rim and the screwdriver. Be aware that considerable force is needed. You can also replace the stand by pushing it back until it snaps in place.

The next illustration shows an example of a PRA-CSLW call station with two extensions PRA-CSE, flush-mounted on a 19 in panel of 5U height. The devices are fixed on the panel by clamping strips, behind the panel, that go into the adapter slots. In this case the M4 inserts are not used and the desktop stands are removed.

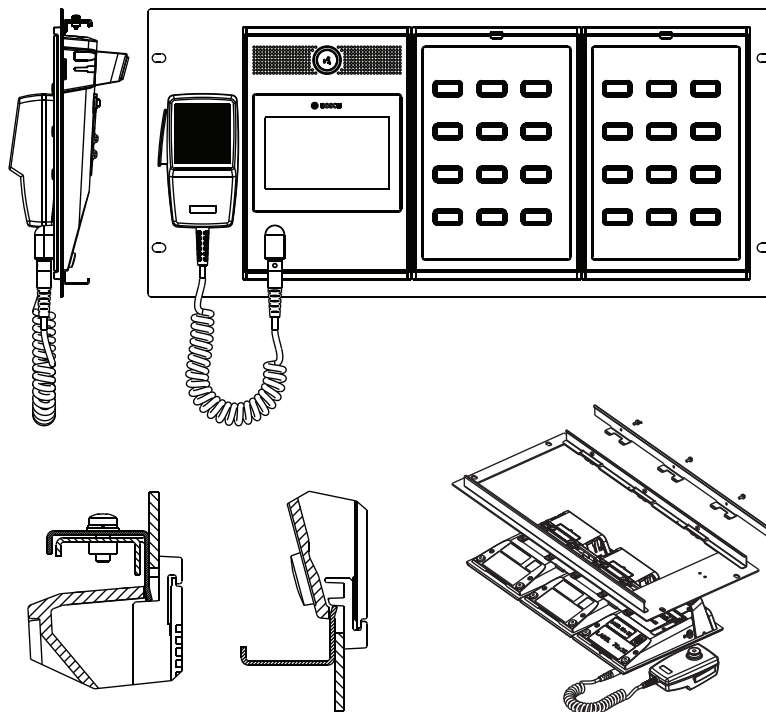

**Caution!**

The call station and its extensions are suitable for vertical mounting below 2m height.

**14.5.9**

**Reset to factory default**

The reset switch resets the device to its factory default settings. This function is only to be used in case a secured device is removed from a system to become part of another system. See *Device status and reset*, page 71.

**14.6**

**Approvals**

<b>Emergency standard certifications</b>	
Europe	EN 54-16 (0560-CPR-182190000)
International	ISO 7240-16
Maritime applications	DNV GL Type Approval
<b>Emergency standard compliance</b>	
Europe	EN 50849
UK	BS 5839-8
<b>Regulatory areas</b>	
Safety	EN/IEC/CSA/UL 62368-1
Immunity	EN 55024 EN 55035 EN 50130-4

<b>Regulatory areas</b>	
Emissions	EN 55032 EN 61000-6-3 ICES-003 FCC-47 part 15B class A
Environment	EN/IEC 63000
Railway applications	EN 50121-4
Maritime applications	EN 60945

## 14.7

### Technical data

#### Electrical

<b>Microphone (PRA-CSLD)</b>	
Nominal acoustic input level (configurable)	80 – 100 dBSPL
Maximum acoustic input level	120 dBSPL
Self noise	< 26 dBSPL
Directivity	Unidirectional
Frequency response (+3 / -6 dB)	100 Hz – 14 kHz

<b>Microphone (PRA-CSLW)</b>	
Nominal acoustic input level (configurable)	89 – 109 dBSPL
Maximum acoustic input level	120 dBSPL
Minimum signal-to-noise ratio	73 dBA
Self noise	< 28 dBSPL
Directivity	Omnidirectional
Frequency response (+3 / -6 dB)	500 Hz – 8 kHz (noise cancelling)
Cable length (stretched)	300 cm

<b>Display</b>	
Size	4.3"
Touch screen	Capacitive
Color depth	24-bit
Resolution	480 x 272 px
Brightness	300 cd/m <sup>2</sup>

<b>Monitor loudspeaker</b>	
Maximum sound pressure level, at 1 m	75 dBSPL
Volume control	Mute, -40 dB – 0 dB
Frequency range (-10 dB)	400 Hz – 8 kHz

<b>Line input</b>	
Frequency range (-3 dB)	20 Hz – 20 kHz
Signal to Noise Ratio (SNR)	> 96 dBA
Total Harmonic Distortion + Noise (THD+N)	< 0.1%
<b>Power transfer</b>	
Power over Ethernet (PoE 1-2) Nominal DC input voltage Standard	48 V IEEE 802.3af Class 3
Power consumption Call station (business use) Call station (emergency use) Per call station extension (indicators off / on)	4.2 W 5.4 W 0.1 W / 1.0 W
Input voltage tolerance	37 – 57 VDC
<b>Supervision (PRA-CSLD)</b>	
Supervision Microphone Audio path Controller continuity PoE (1-2)	Current Pilot tone Watchdog Voltage
<b>Supervision (PRA-CSLW)</b>	
Supervision Microphone Audio path Press-to-talk switch Controller continuity PoE (1-2)	Impedance Pilot tone Impedance Watchdog Voltage
<b>Network interface</b>	
Ethernet  Protocol Redundancy	100BASE-TX, 1000BASE-T TCP/IP RSTP
Audio/control protocol Network audio latency Audio data encryption Control data security	OMNEO 10 ms AES128 TLS
Ethernet ports	2
<b>Reliability</b>	
MTBF (calculated according to Telcordia SR-332 Issue 3)	1,000,000 h

**Environmental**

<b>Climatic conditions</b>	
Temperature Operating	-5 – 50 °C (23 – 122 °F)
Storage and transport	-30 – 70 °C (-22 – 158 °F)
Humidity (non-condensing)	5 – 95%
Air pressure (operating)	560 – 1070 hPa
Altitude (operating)	-500 – 5000 m (-1640 – 16404 ft)
Vibration (operating) Amplitude Acceleration	< 0.35 mm < 5 G
Bump (transport)	< 10 G (IEC 60068-2-27)

**Mechanical**

<b>Enclosure (PRA-CSLD)</b>	
Dimensions (HxWxD) Excluding microphone	62 x 130 x 189 mm (2.44 x 5.12 x 7.44 in)
Ingress protection	IP30
Base Material Color	Zamak RAL9017
Panel Material Color	Plastic RAL9017 RAL9022HR
Weight	0.9 kg (1.98 lb)

<b>Enclosure (PRA-CSLW)</b>	
Dimensions (HxWxD)	62 x 130 x 189 mm (2.44 x 5.12 x 7.44 in)
Ingress protection	IP30
Base Material Color	Zamak RAL9017
Panel Material Color	Plastic RAL9017 RAL9022HR
Weight	1.0 kg (2.21 lb)

## 15 Call station extension (CSE)



### 15.1 Introduction

This keypad extension is used in combination with PRAESENSA call stations to make selections for business and alarm calls.

One device adds twelve configurable buttons with light ring. Each button has two additional indicators for user feedback, related to the configured functionality of that button.

Up to four PRA-CSE can be connected to one call station. Using extension keypads for zone selection allows all zones to be accessible and visible at the same time. It shows a complete status overview of selected and occupied zones or zones with faults.

The extension keypad is delivered with a metal coupling plate and patch cable to link it to a call station or other extension keypad.

The front cover can be easily removed to insert labels with up to three lines of text per button and a header section on top.

### 15.2 Functions

#### Business operation

- Connection of up to four PRA-CSE extensions, each with twelve buttons. The buttons can be configured for various functions, but they are especially useful for zone selection, giving a clear overview of accessible zones and the LED indicators for each button show the status of the respective zone (like being selected, occupied or at fault).

#### Emergency operation

- The call station extension complies to the standards for voice alarm applications, when the fireman's user interface is configured for the call station and at least one PRA-CSE is connected to it.
- All critical alarm functions are accessible via buttons for operators wearing gloves.
- All indicators of the extension take part in the indicator test function of the connected call station.

#### Connection

- Reliable, locked, single cable interconnection between call station and extension and between extensions.
- Robust metal coupling plate.
- All extensions are automatically addressed, from left to right.
- All assembling can be done with one standard Torx TX10 screwdriver.

#### Labeling

- Removable front cover for easy labeling with space for three lines of text per button.



**Button cap**



- Three button caps are included to prevent unintended activation of critical buttons.

### 15.3 Functional diagram

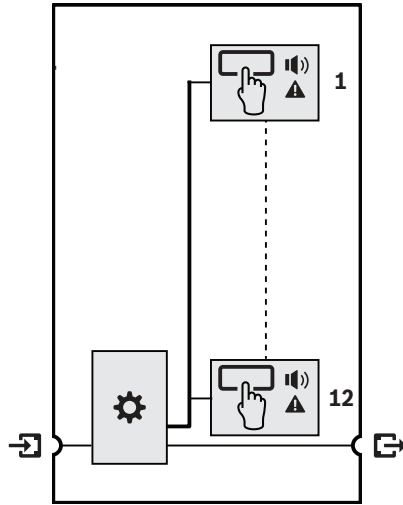
**Functional and connection diagram**





**Internal device functions**

-  Controller
-  Zone status indicator
-  Zone fault indicator

### 15.4 Indicators and connections



**Top-side indicators**

	Selection button LED ring (1-12) Selected	White		Active (1-12) Evacuation call Business call Music	Red Blue Green
	Zone fault present (1-12)	Yellow			

The brightness adjustment of the LEDs is only supported on devices with HW version 01/01 and higher.

**Top-side controls**

	Selection (1-12)	Button			
---	------------------	--------	--	--	--

**Bottom-side interconnections**

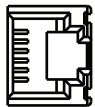
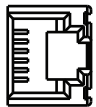

↪	Connection to next extension (RJ12)		↩	Connection to call station or previous extension (RJ12)	
---	-------------------------------------	---	---	---	---

**15.5**

**Installation**

The PRA-CSE is used in combination with a PRA-CSLD and PRA-CSLW call station.

**Refer to**

- LCD call station (CSLD, CSLW), page 185

**15.5.1**

**Parts included**

The box contains the following parts:

Quantity	Component
1	Call station extension
1	Bracket (attached to bottom)
1	Metal coupling plate + 4 screws
1	RJ12 interconnection cable
1	Button cap (x3)
1	Quick Installation Guide
1	Safety and security information

No tools or Ethernet cables are provided with the device.

### Parts check and identification

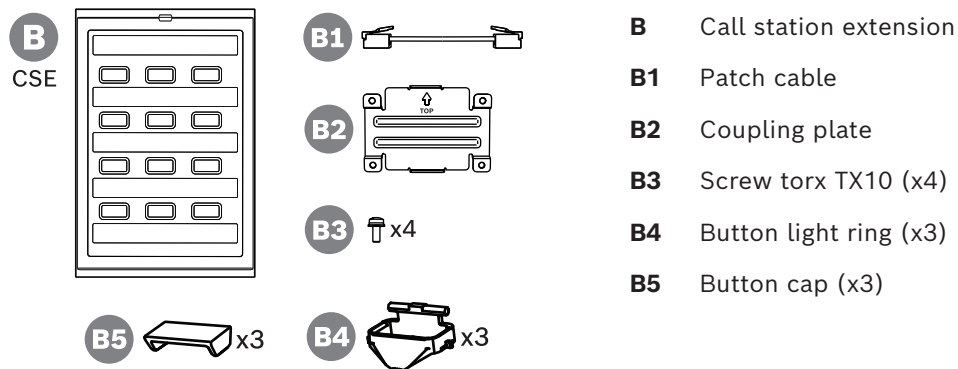

## 15.5.2

### Extension connected to a call station

Add up to four PRA-CSE call station extensions for zone selection and other functions. Without extensions the call station can only be used with a pre-configured zone selection. A call station (A) will automatically assign a connected extension (B) to itself and number the extensions in succession. Manual addressing is not needed and not possible. The system will supervise that a configured extension remains connected to its call station. The extension that is mounted immediately next to the call station is the first extension in the configuration. All extensions communicate with their call station via a short loop-through cable with RJ12-connectors. The same connection provides power to the extensions. Extensions cannot be used without call station.

To mount and connect a call station extension, follow the procedure below:

1. Remove the cable covers at the bottom of the call station and the extension using a TX10 screwdriver.
  - For the call station, get access to the two screws via the holes in the table stand bracket.
2. Mount the coupling plate between the call station and the first extension, using four M3 screws with TX10 head.
  - Mounting plate and screws are included with the extension.
  - An extension can only be mounted to a call station on its right hand side (looking from above).
3. Connect the short RJ12-cable between the call station and the (first) extension.
  - This cable reversible and can be used in either direction. The RJ12-cable is included with the extension.
4. While the call station is not yet connected to the network, use one or two Gb-Ethernet cables, preferably CAT6A F/UTP, with RJ45 connectors to connect the call station to a PSE port, with PoE enabled.
5. Cut off the small break-off part of the cable cover of the call station to make space for the RJ12-cable to pass through.
  - This break-off part covered the RJ12-socket when it was not used.
6. Put back both cable covers, each with its two TX10 screws.
  - The cable covers prevent that the RJ12-cable can be pulled out. For the call station, the cable cover also prevents access to the Reset switch.

Follow the same procedure for mounting an additional extension to an already mounted extension.

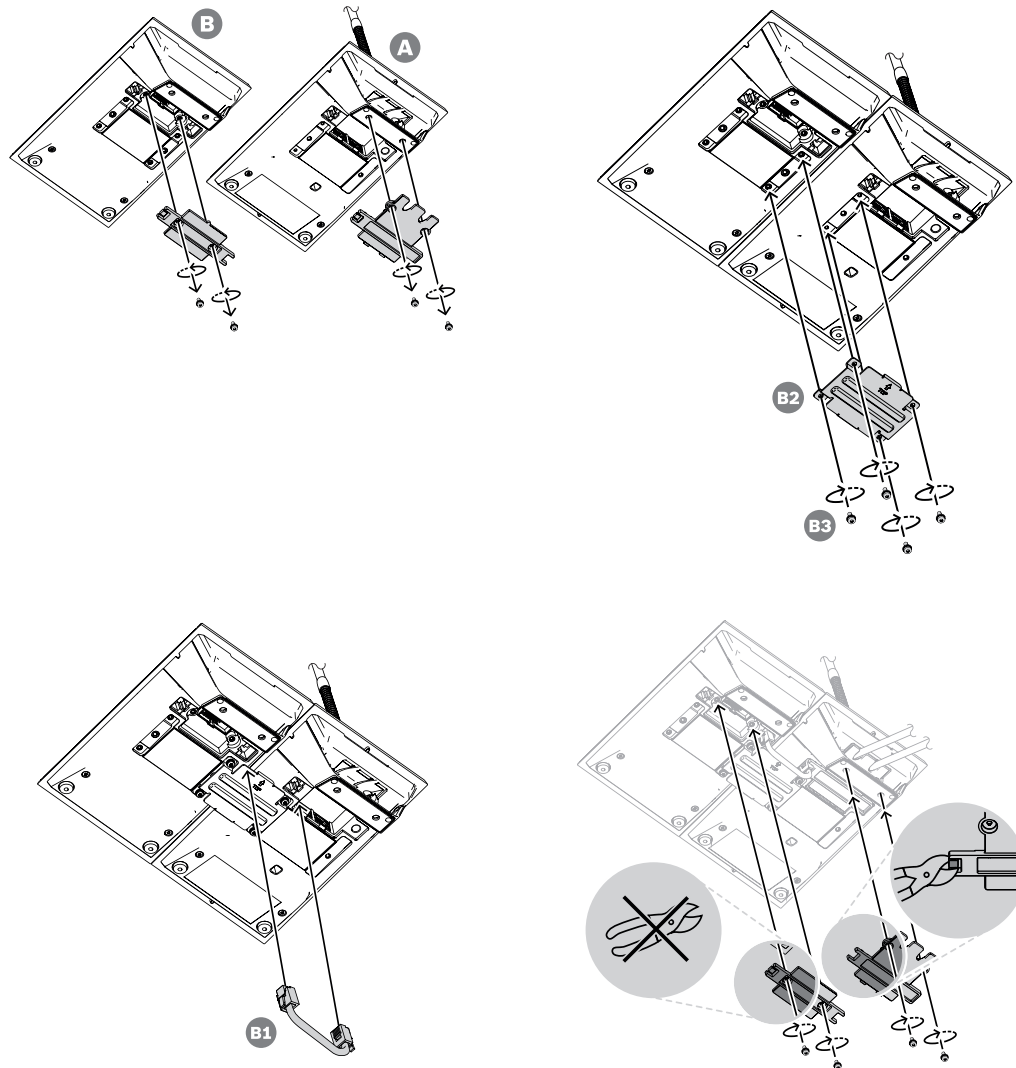

### 15.5.3

#### Labeling

The call station extension has provisions to label the keys with custom texts and/or symbols, but also the extension itself can be labeled.

To add or change labels follow the procedure below:

1. The extension top cover is fixed in place with magnets. Use a screwdriver or tweezers in the slot of the extension cover plate to lift up the top cover.
2. Slide the cover upwards to remove it.
3. Turn the cover upside down. Gently push a screwdriver or tweezers into the hole in the metal top side label holder. Slide the label holder to the left to unlock and then up to remove.
  - This label holder is for the title label of the extension. It is made of metal and is also used to fix the top cover magnetically to the body of the enclosure.
4. Gently push a screwdriver or tweezers into the holes of the plastic label holders for the keys and lift them up to remove.
5. Type in the texts for the title label and the key labels using the available template. Then print on paper and cut to size.

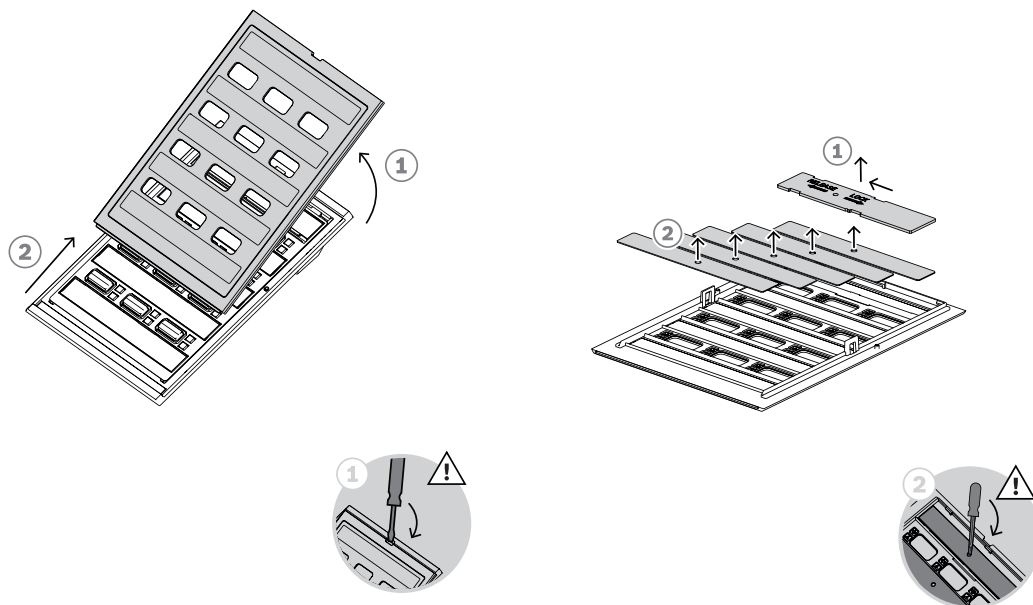

6. Place the labels upside down in the label slots and put the label holders back in place. Slide the metal top side label holder to the right to lock it in place.
7. Mount the cover back on the extension body by first sliding the bottom side into the body, then tilt down until it snaps into place.

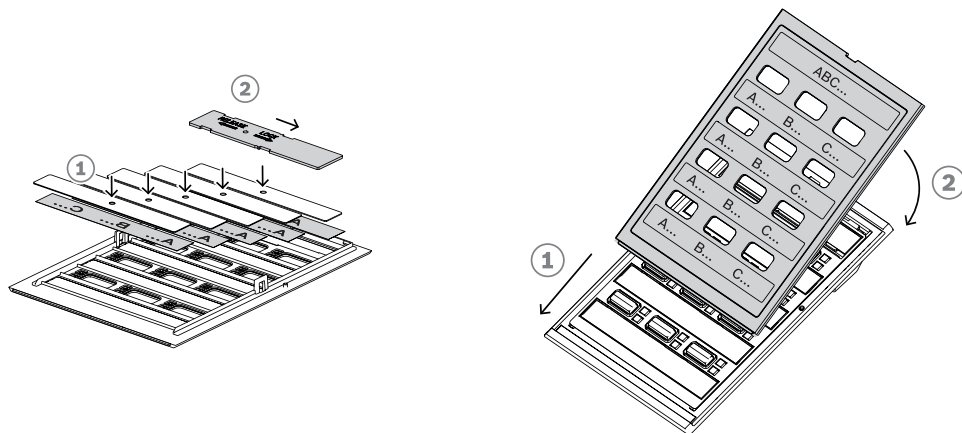

## 15.5.4 Mounting a button cap

The call station extension has provisions to add a cap over one or more buttons, as a safeguard against accidental activation. Each PRA-CSE is delivered with a set of three caps, each consisting of a white light ring with pivot pins and a red cap with a hinge.

To mount a button cap, follow the procedure below:

1. The extension top cover is fixed in place with magnets. Use a screwdriver or tweezers in the slot of the extension cover plate to lift up the top cover.
2. Slide the cover upwards to remove it and get access to the buttons.
3. Translucent light rings are placed in rows of three around the buttons. Use tweezers to lift and remove the row for the button that should get a cap.
4. Remove the original light ring by cutting the plastic bridges to the adjacent light rings. Leave part of the plastic bridges in place around each light ring for better orientation when it is put back in place.
5. Insert one of the new light rings with pivot pins in the slot around the button that should get a cap. The pivot pins must be on top.
6. Then place the original light rings back around the remaining buttons.
7. Mount the cover back on the extension body by first sliding the bottom side into the body, then tilt down until it snaps into place.

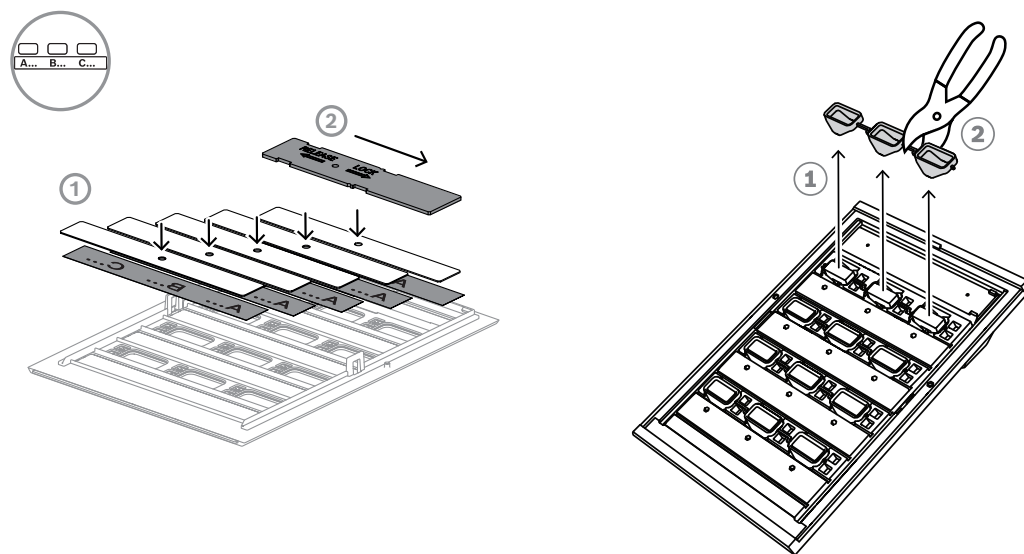

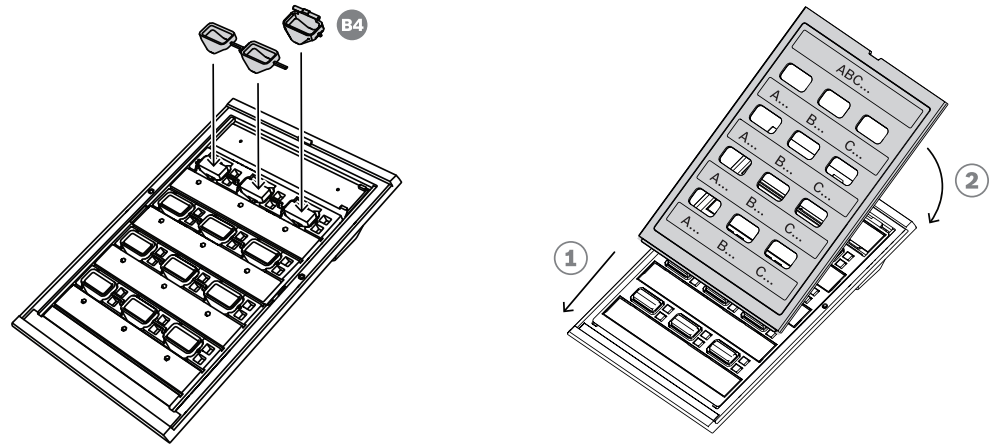

8. The red cap has a hole on one side of the hinge for the left pivot pin, and a slot on the other side of the hinge for the right pivot pin. Rotate the cap 10 degrees, counterclockwise, and slide to the right over the button, so the left pivot pin goes into the hole of the hinge. Then push the right side of the cap down until the right pivot pin snaps into the slot of the hinge. This requires some force.
9. After the cap has snapped into place, the hinge has two stable positions and the cap can be flipped into the open or closed position.

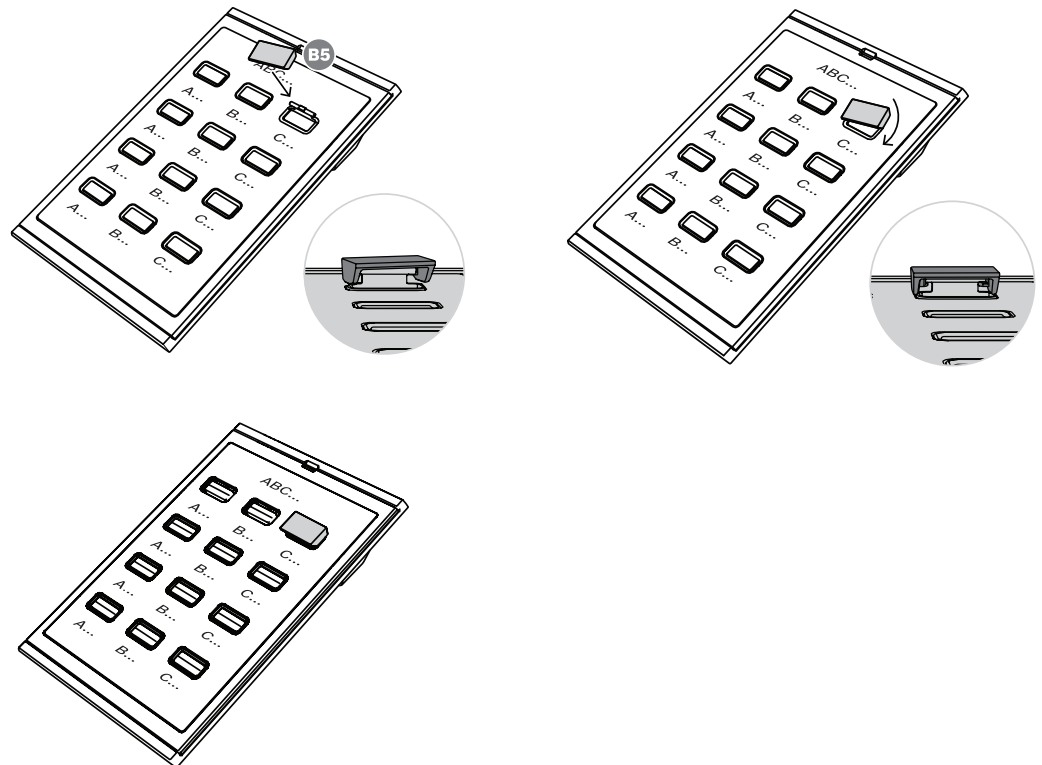

**Notice!**

If more than the three button caps delivered with the device are needed, order a set of 30 button caps as a service item with the material number F.01U.399.317.

## 15.6 Approvals

Emergency standard certifications	
Europe	EN 54-16 (0560-CPR-182190000)
International	ISO 7240-16
Maritime applications	DNV GL Type Approval
Emergency standard compliance	
Europe	EN 50849
UK	BS 5839-8
Regulatory areas	
Safety	EN/IEC/CSA/UL 62368-1
Immunity	EN 55035 EN 50130-4
Emissions	EN 55032 EN 61000-6-3 ICES-003 FCC-47 part 15B class A
Environment	EN/IEC 63000
Railway applications	EN 50121-4
Maritime applications	EN 60945

## 15.7 Technical data

### Electrical

Power transfer	
Power supply input	
Input voltage	5 VDC
Input voltage tolerance	4.5 – 5.5 VDC
Power consumption (indicators off / on)	0.1 W / 1.0 W
Supervision	
Interconnection	Link presence
Processor	Watchdog
Reliability	
MTBF (extrapolated from calculated MTBF of PRA-CSLD and PRA-CSLW)	2,400,000 h



**Environmental**

<b>Climatic conditions</b>	
Temperature	
Operating	-5 – 50 °C (23 – 122 °F)
Storage and transport	-30 – 70 °C (-22 – 158 °F)
Humidity (non-condensing)	5 – 95%
Air pressure (operating)	560 – 1070 hPa
Altitude (operating)	-500 – 5000 m (-1640 – 16404 ft)
Vibration (operating)	
Amplitude	< 0.35 mm
Acceleration	< 5 G
Bump (transport)	< 10 G (IEC 60068-2-27)

**Mechanical**

<b>Enclosure</b>	
Dimensions (HxWxD)	62 x 130 x 189 mm (2.44 x 5.12 x 7.44 in)
Ingress protection	IP30
Base	
Material	Zamak
Color	RAL9017
Panel	
Material	Plastic
Color	RAL9017 RAL9022HR
Weight	0.4 kg (0.88 lb)

## 16 Call station kit (CSBK)



### 16.1 Introduction

The basic call station kit is an open frame call station to create dedicated full custom operator panels for PRAESENSA Public Address and Voice Alarm systems. It has the same functionality as the PRA-CSLW, but without LCD user interface to facilitate easier mounting in operator desks or in wall-mounted fireman's panel enclosures.

It comes with a detachable, supervised omnidirectional fist microphone for close talking with press-to-talk button and a separate small monitor loudspeaker.

The kit has a CAN-bus interface on RJ12 to one or two PRA-CSEK Call station extension kits for connection of selection switches and status indicator LEDs, or to connect to a full custom control board with switches and indicators. The interface is compatible with the PRA-CSE and one to four of these devices can be connected.

The kit only requires a connection to an OMNEO IP-network with Power over Ethernet (PoE) for communication and power supply combined. It can be configured as business and emergency call station.

The PRA-CSBK is considered a component that must be installed in a final product. The final product must be reconfirmed to meet applicable EMC directives.

### 16.2 Functions

#### IP-network connection

- Direct connection to the IP-network. One shielded Ethernet cable is sufficient for Power over Ethernet and data exchange.
- Connect a second shielded Ethernet cable for dual redundancy of network and of power connection.
- Integrated network switch with two OMNEO ports allows for loop-through connections to adjacent devices (at least one must provide PoE). Rapid Spanning Tree Protocol (RSTP) is supported to enable recovery from failing network links.

#### Business operation

- Press-to-talk switch on fist microphone. Without call station extension panels connected, the press-to-talk switch can be used to make calls to a pre-configured set of zones.
- Fixed level monitor loudspeaker.
- Local audio line input (with stereo to mono conversion) for connecting an external audio source. The audio channel will be available on the network and can be played in any loudspeaker zone.

- CAN-bus interface with power supply on RJ12 connector for connection to a full custom user interface board with selection switches and status indicator LEDs. This connection can also be used for up to four cascaded PRA-CSE Call station extension panels or up to two cascaded PRA-CSEK Call station extension kits.

**Emergency operation**

- The basic call station kit fully complies to the standards for voice alarm applications when configured correctly in combination with one or more call station extensions or a custom user interface panel. The PRA-CSBK is considered a component that must be installed in a final product. The final product must be reconfirmed to meet applicable voice alarm standards, or must be certified.
- Each of the two RJ45 network connectors accept PoE to power the call station. This provides fail-safe network connection redundancy, as one connection is sufficient for full operation.
- Supervision of all critical elements; the audio path is supervised, as well as the communication to the network.

### 16.3 Functional diagram

Functional and connection diagram

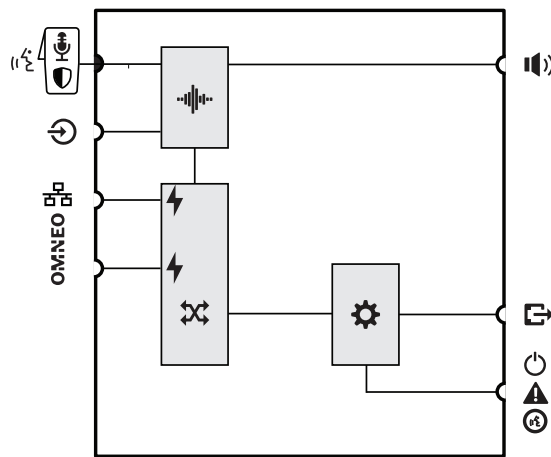

Internal device functions

- Audio processing (DSP)
- Power over Ethernet
- OMNEO network switch
- Controller

## 16.4 Indicators and connections

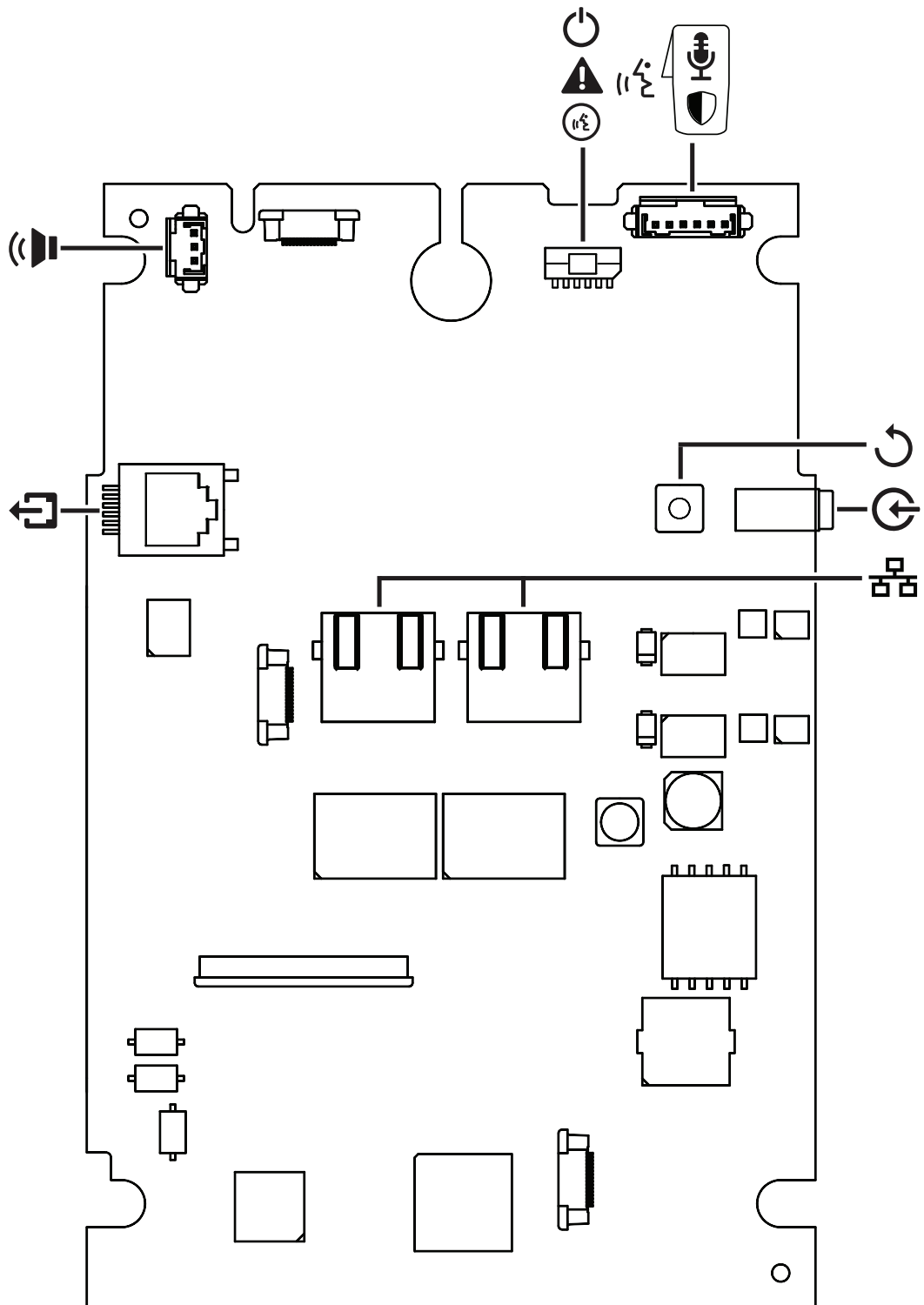

Top side



**Top side indicators**

	100 Mbps network 1-2 1 Gbps network1-2	Yellow Green		
---	---	-----------------	--	--











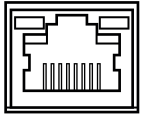

**External indicators (also present on bottom side)**

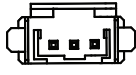
	Power on Device in identification mode	Green Green blinking		System fault present Yellow
	PRA-CSLW Status business call Microphone active Chime/message active  Status emergency call Microphone active Alarm tone/message active	Green Green blinking  Red Red blinking		Identification mode / Indicator test All LEDs blink

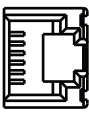
**Top side controls**

	Device reset (to factory default)	Button		
---	-----------------------------------	--------	--	--

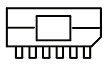
**Top side interconnections**

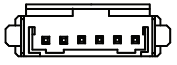
	Network port 1-2 (PoE PD)			Local source audio line input 
	Monitor loudspeaker			PRA-CSE(K) interconnection (RJ12) 
  	LED indicators for power, system fault and call/microphone status			Microphone with Press-To-Talk switch 

**External components**

	Microphone with Press To Talk switch	Included		Monitor loudspeaker	Included
---	--------------------------------------	----------	---	---------------------	----------

**16.5**

**Installation**

The basic call station kit is an open frame call station to create dedicated full custom operator panels (without LCD) for PRAESENSA Public Address and Voice Alarm systems. It is designed to become part of a final product, combined with a user interface for selection of operational functions or zones, or used as stand-alone call station with a pre-configured zone selection.



**Notice!**

The PRA-CSBK is considered a component that must be installed in a final product. The final product must be reconfirmed to meet applicable EMC directives and safety standards.

**16.5.1**

**Parts included**

The box contains the following parts:

Quantity	Component
1	Call station circuit board
1	Microphone with coiled cable and connector
1	Grommet with connector socket and extension cable
1	Grommet lock
1	Miniature loudspeaker
1	Interconnection cable for loudspeaker
1	Interconnection cable for indicators
1	Interconnection cable for extension
1	Set of mounting studs and grommets
4	Self-tapping screw (3 x10 mm TX10)
1	Microphone bracket
1	P-clip for microphone cable
1	Quick installation guide

No tools or Ethernet cables are provided with the device.

**Parts check and identification**

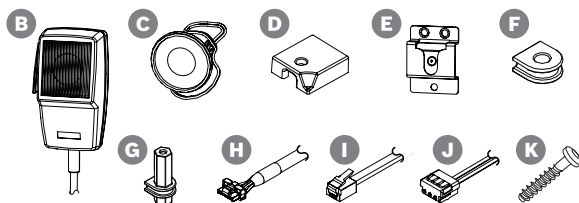
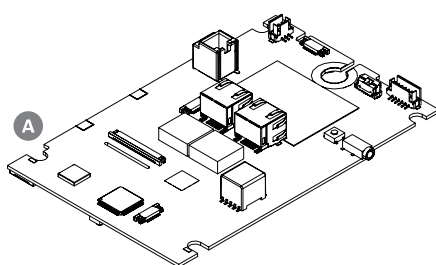

- A** Call station board
- B** Handheld microphone with cable and cable extension with connector
- C** Monitor loudspeaker with short cable
- D** Grommet lock for microphone cable
- E** Microphone clip
- F** Isolated mounting grommets (x4)
- G** Isolated mounting studs (x4)
- H** Cable for status LEDs
- I** CAN-bus extension patch cable
- J** Long loudspeaker cable

- K** Mounting screws for G (x4)  
(3 x 10 mm TX10)

### 16.5.2 Enclosure requirements

The PRA-CSBK is considered a component that must be installed in a final product. Compliance of the final product to EN/IEC/UL 62368-1 is mandatory. This standard uses a hazard-based approach to safety analysis. The basic intention of 62368-1 is to give designers greater flexibility to design safety measures in keeping with their products, while at the same time requiring rigorous analysis to ensure that all products are safe to use and cannot cause bodily injury or fire. For compliance of the final product that uses the PRA-CSBK, observe the following classifications and make sure that the final product has adequate safety barriers to prevent harm to users.

- Electrically caused injury: class 1 (ES1), because the PoE voltage is <60 VDC.
- Electrically caused fire: class 2 (PS2), because the maximum PoE power dissipation is between 15 and 100 W.
- Mechanically caused injury: class 2 (MS2), because the unprotected PRA-CSBK has sharp edges. There are no moving parts.
- Thermal burn: class 1 (TS1), because external surfaces that need not be touched to operate the equipment have a temperature <70°C.
- There are no radiation energy sources (RS) and potential ignition sources (PIS) present.

For PS2 and MS2, the enclosure of the final product must be designed to prevent harm to ordinary users. For good EMC and thermal performance, also some other measures must be taken into account.

1. For fire safety (PS2), the enclosure material must be metal or plastic with a UL94V-0 flammability rating. When a metal enclosure is used and compliance to UL 864 / UL 2572 is needed, it must be connected to safety ground because the internal voltages may exceed 42.4 V<sub>peak</sub>.
2. For mechanical safety (MS2), the PRA-CSBK must be completely enclosed, so it is not accessible. Furthermore, the final product should not be mounted more than 2 m above floor level.
3. For sufficient cooling, the enclosure must have a minimum size of approximately 30 x 20 x 5 cm (12 x 8 x 2 in). The enclosure of the PRA-CSLx is smaller because it uses the metal bottom part of the enclosure for cooling of some critical components. The PRA-CSBK can be mounted horizontally with the RJ45 network connectors on top, or it can be mounted vertically.
4. When a metal enclosure is used, for good EMC performance the ground of the PRA-CSBK shall not be connected to the metal enclosure.
5. Only the Ethernet network cables are allowed to leave the enclosure (field wiring). For good EMC performance, all other wiring must stay inside the enclosure and the supplied cables are not allowed to be extended.

### 16.5.3 Mounting

Mount the call station board on a flat surface only. Drill or punch the holes for the mounting studs (G) on a 95 mm x 136 mm rectangular pattern. Slide the four studs into the slots of the board, one at each corner. For mechanical stability, all four must be used. To fix the studs on the mounting base, use self-tapping screws (K), head TX10, size 3x10 mm.

Alternatively, when the mounting base has studs already, minimum height 5 mm, use the four isolated mounting grommets (F) with M3 (1/8 in) bolts and nuts. Prevent short circuits between components on the bottom of the board and a metal mounting base. If needed, use an isolation foil in between.



### Notice!

The board contains many sensitive components, both with respect to mechanical stress and electrostatic discharge (ESD). Avoid bending of the board and observe precautions for handling electrostatic discharge sensitive devices.

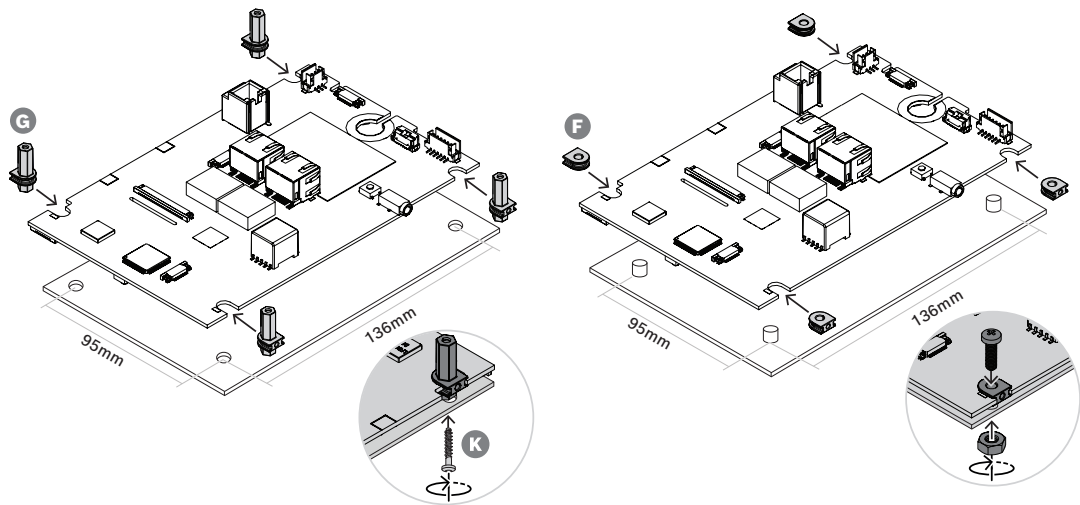

## 16.5.4

### Microphone connection

The microphone, delivered with the PRA-CSBK, is a dynamic microphone for close distance talking. The microphone is the same as for the PRA-CSLW, see section *Call station microphone frequency response*, page 193 for its frequency response. The microphone and its connection are supervised by monitoring the impedance of the microphone. The Press-To-Talk switch of the microphone and its connection are supervised for shorts and open circuits, using two integrated 10 kohm resistors, in the same way as described for the control inputs of the PRA-MPS3, see chapter *Control inputs*, page 152.

The microphone has a coiled cable with a lockable 6-pin mini-XLR connector. The connector plugs into the socket in the feed-through grommet for the panel where the microphone is mounted on. The maximum panel thickness is 5 mm and the cable grommet requires a rectangular hole of 11.5 mm x 14.3 mm. If the panel is thicker than 3 mm, the cable exit of the grommet requires an additional cutout to prevent that the cable is squeezed when the grommet lock is pushed on.

1. Thread the cable of the feed-through grommet through the hole until the grommet is on the panel surface.
2. Behind the panel, push the grommet lock onto the grommet till it snaps in place. For a tight fix of the grommet, the space between the rear side of the panel and the grommet lock needs to be filled up to 5 mm thickness with one or more rectangular plate washers, or use a 5 mm panel.
3. Insert the polarized cable connector into its 6-pin socket on the board.
4. Use the microphone holder to mount the microphone in place.



5. Plug the lockable 6-pin connector of the microphone cable into the socket on the panel.  
To unlock the connector, press the unlock button with a sharp tool, such as a paper clip.

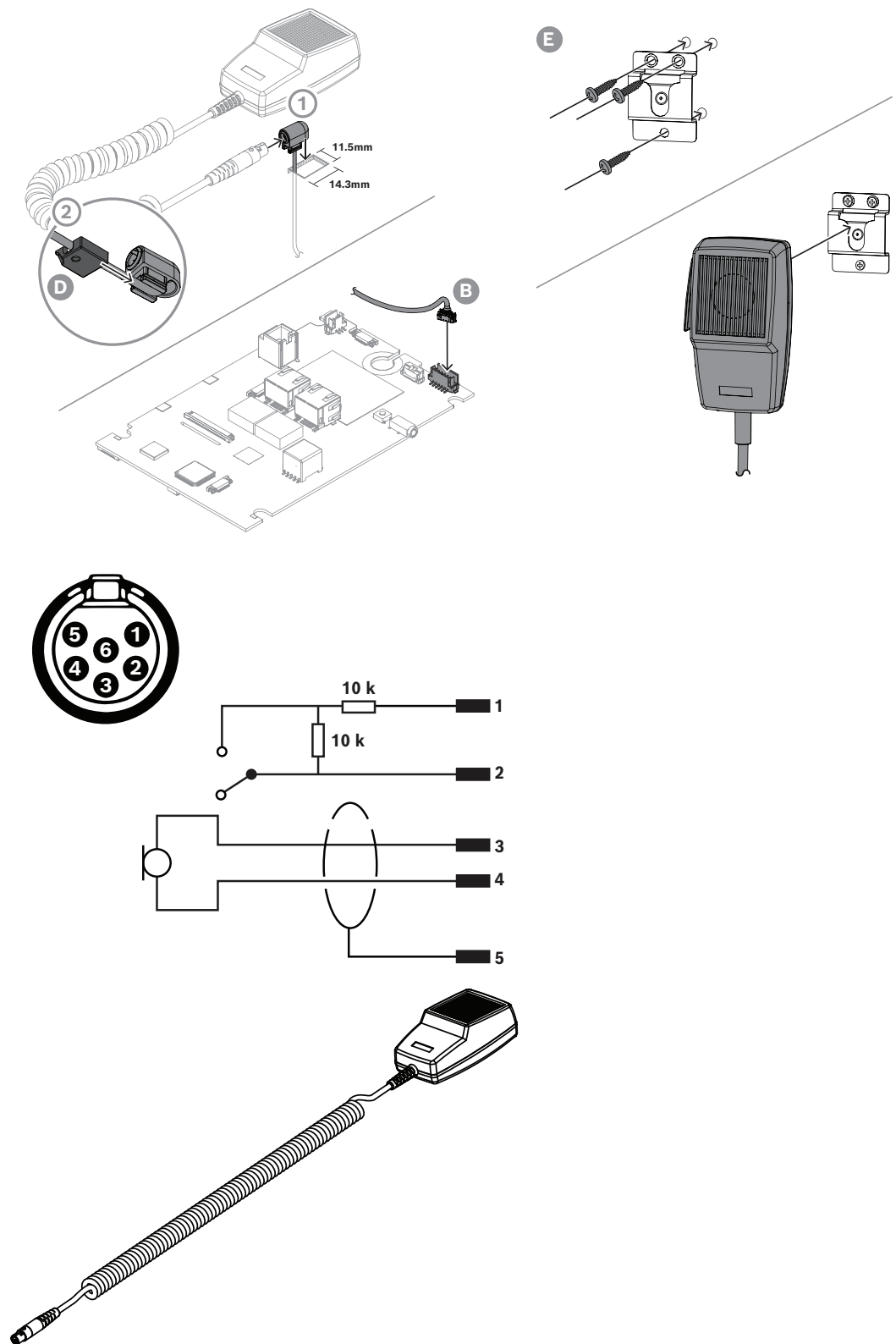

In case a (removable) front panel connector is needed for the microphone, use the microphone connection circuit diagram and wire color table for identification of the wires.

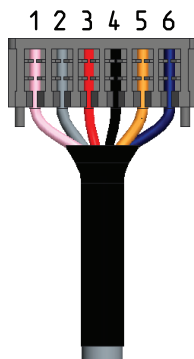

Microphone	Coiled cable wire colors	Extension cable wire colors	Board connector
Switch 1	Blue	Pink	Pin 1
Switch 2	Black	Grey	Pin 2
Signal +	Red	Red	Pin 3
Signal -	White	Black	Pin 4
Shield	Blank	Blank, Blue	Pin 5, Pin 6

**Refer to**

- Call station microphone frequency response, page 193
- Control inputs, page 152

**16.5.5**

**Loudspeaker connection**

The supplied miniature loudspeaker (C) is a 1.5 W loudspeaker with an impedance of 8 ohm and a sensitivity of 82 dB SPL at 1 W, 0.5 m. It comes with a short (8 cm) interconnection cable with a connector attached. The connector has three pins, but only two pins are used. Insert the polarized cable connector into its 3-pin socket on the board.

A separate longer (50 cm) interconnection cable (J) is also provided, for when the loudspeaker must be mounted further away from the call station board. To use the longer cable, cut off the short one from the loudspeaker and solder the long one in its place. The polarity of the loudspeaker is irrelevant in this application.

This 28 mm loudspeaker is the same as is used in the PRA-CSLD and PRA-CSLW. Because it has no mounting provisions, use e.g. hot glue or edge clamps for mounting. It requires a baffle opening of 26 mm diameter with a depth of at least 0.8 mm for diaphragm moving.

The PRA-CSBK doesn't have a touch screen to support volume control of the monitor loudspeaker. The volume setting is fixed to 0 dB (maximum) when the loudspeaker acts as a buzzer for audible notification of the fault status or emergency status. The volume setting is fixed to -20 dB when it is used to monitor announcement chimes and prerecorded messages. It should not be possible for the operator of the final product, in which the PRA-CSBK is used, to change the volume of the buzzer for audible notifications. In the final product the level of the loudspeaker can be decreased by adding a series resistor, but the buzzer level has to be verified to fulfill the applicable standards.

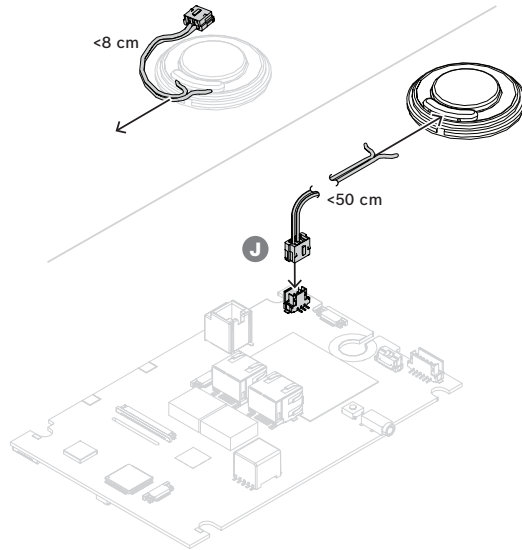

### 16.5.6

#### Status LEDs connections

The LEDs that are visible on the front panel of the PRA-CSLW are also present and operational on the bottom side of the board, as this is a variant of the same board. To be able to use indicators on a different location on a custom call panel, logical outputs are provided on a connector on the top-side. Use cable (H) to connect the logical outputs to appropriate LED drivers to drive the LEDs. The logical outputs cannot drive LEDs directly. The logical output levels are 0 V (indicator off) or 3.3 V (indicator on). A 6-pin connector is used. See the illustration for pinning order.

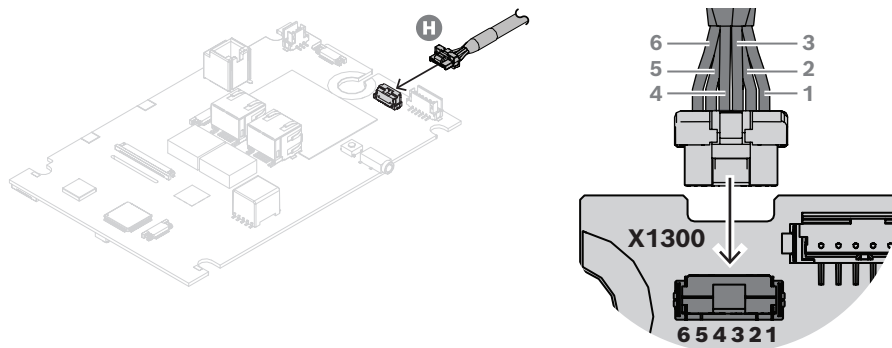

The table shows the pin numbers, wire colors, the corresponding indicator functions and the recommended color for the indicator LEDs.

Connector	Wire color	Indicator function	Icon	LED color
Pin 1	Black	Power on		Green
Pin 2	Red	System fault		Yellow
Pin 3	White	Microphone/call status (emergency priority)		Red
Pin 4	Green	Microphone/call status (business priority)		Green

Connector	Wire color	Indicator function	Icon	LED color
Pin 5	Yellow	Ground		
Pin 6	Blue	Microphone/call status (reserved)		Blue

These logical signals can be read by a micro-controller on the custom extension panel or used as inputs for appropriate LED drivers.

Because blue LEDs and also some green LEDs have a forward voltage above 3 V, the LEDs need a supply voltage of e.g. 5 V to accommodate a series resistor to set a stable current. A current limited supply voltage of 5 V is available on the RJ12 connector for the CAN-bus. In this way the whole product can be powered from PoE via Ethernet, without using a separate power supply (with battery backup).

A LED driver can be as simple as using a section of a ULN2004 (a common driver IC), that contains an inverting darlington driver, switching perfectly with a 0/3.3 V input. The value of the series resistor for each LED determines the current in on-state. An alternative, discrete circuit is also shown. This is a switched constant current sink, for which the current is determined by the 150 ohm emitter resistor. The 100 ohm series resistor is here only to limit the dissipation in the driver transistor, its value depends on the chosen LED-current and the forward voltage of the LED.

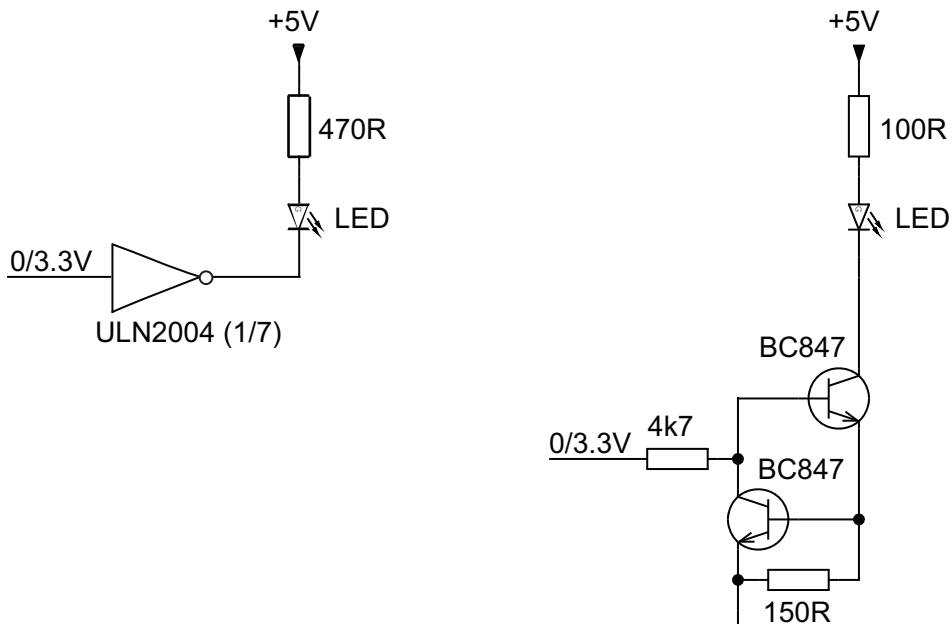

### 16.5.7 Interconnection call station / extension

The PRA-CSBK can be used in different ways:

- Stand-alone; no connection to an extension is required. Only the pre-configured action is possible.
- In combination with one to four PRA-CSE call station extensions for zone selection and/or other functions. When connected with PRA-CSE devices, the call station will automatically assign all connected extensions to itself and number the extensions in

succession. Manual addressing is not needed and not possible. The system will supervise that a configured extension remains connected to its call station. Refer to: *Extension connected to a call station, page 203.*

- In combination with a PRA-CSEK, an open frame call station extension kit with connectors for custom switches and status LEDs.
- With a custom user interface extension, connected to the CAN-bus of the PRA-CSBK. This user interface extension makes use of the documented protocol between a PRAESENSA call station and its standard extensions, effectively mimicking a set of extensions. This even allows the designer of the user interface extension to create automated actions for the call station by reading the status of the system or zones from the status LED information on the bus and sending simulated button activations to the call station.

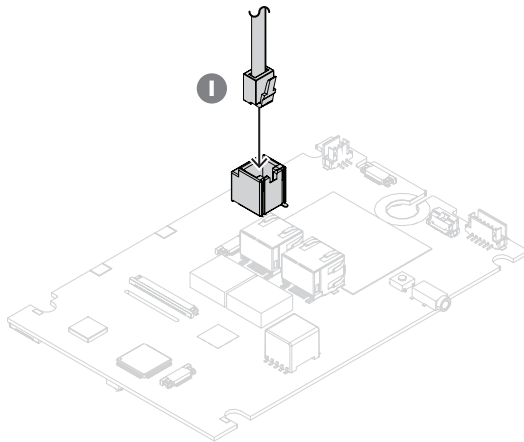

The interconnection between the PRA-CSBK and its extension(s) is via the CAN-bus patch cable (I). The pinning of the RJ12 connector is as follows:

RJ12 CAN-bus	Function	Socket
Pin 1	+5 V (not current limited)	
Pin 2	+5 V (current limited to 0.8 A +/- 20 %)	
Pin 3	CAN H	
Pin 4	CAN L	
Pin 5	Extension counting	
Pin 6	Ground	

On pin 1 a 5 V supply voltage is available, which is connected to the 5 V supply of the PRA-CSBK itself. An overload of this output will switch off the PRA-CSBK completely. This should be avoided, but this output can be used to power the CAN-bus transceiver and processor of the custom extension board. A maximum of 1 A can be taken from this output without affecting the operation of the PRA-CSBK.

On pin 2 a current limited 5 V supply voltage is available. It is derived from the 5 V supply on pin 1, so the load current on pin 1 and 2 together should be <1 A. This output is current limited to 0.8 A +/-20%. Because of this tolerance it is advised to keep the maximum load

current < 0.64 A. This output can be used to drive LEDs or other loads. An overload of this supply voltage will not affect the operation of the PRA-CSBK, as long as the maximum load current of 1 A for pin 1 and pin 2 together is not exceeded.

On pin 3 and pin 4 the CAN-bus is available. On the PRA-CSBK it is connected to an NCV7351 CAN-transceiver, terminated with 120 ohm. On a custom call station extension also a 120 ohm termination resistor must be connected between CAN H and CAN L.

On pin 5 a logical signal (0/3.3 V) is present that enables the PRA-CSBK to identify and number the connected PRA-CSE call station extensions automatically (range 0 - 4).

Pin 6 is connected to ground; this is the reference and return path of the 5 V power supply.

#### **Refer to**

- *Extension connected to a call station, page 203*

### **16.5.8**

#### **Power over Ethernet**

The call station has two Ethernet connection ports with a built-in Ethernet switch, supporting RSTP. The call station is a PoE Powered Device (PD). It provides the correct signature and classification to power sourcing equipment (PSE), so that a PSE sources the right amount of power to a PD over the Ethernet cables. Although it is sufficient to provide PoE power to only one port, both Ethernet ports take PoE power for cable redundancy and supply redundancy. For best availability it is advised to connect each port to a different, independent PSE, such as a PRA-MPS3 multifunction power supply (ports 1 and 2) or a PRA-ES8P2S Ethernet switch (ports 1-8). In case one of the connections fail, or one of the PSE sources fail, the operation of the call station is not affected. With both connections to the same PSE, there is still connection redundancy but no PSE redundancy.

The ports of the call station can be looped through to another PRAESENSA device, but at least one port must be connected to a PSE to power the call station and its extensions. With only one port connected to a PSE, there is no connection redundancy.

The call station ports cannot source PoE power to subsequent devices, such as another call station.

On the call station kit, both Ethernet connectors are surface mounted parts without additional mechanical support. These connectors should not be mechanically stressed. Inserting connectors with thick and rigid installation cables may cause the connectors to break off the board. Use flexible extension cables for the final stretch to the connectors, with proper fixation of the extension cables inside the final product.

To connect the call station, follow the procedure below:

1. Use one or two shielded Gb-Ethernet cables (preferably CAT6A F/UTP) with RJ45 connectors to connect the call station to a PSE port, with PoE enabled.
2. Fixate the cables with tie-wraps and/or cable glands as a strain relief. The strain relief will prevent mechanical force applied to the exterior of a cable from being transferred to the electrical terminations within the connector and to the connector soldering pads.

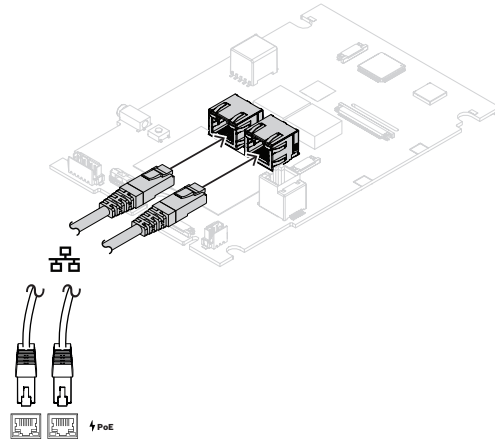

### 16.5.9 Ethernet network

The network must be set up in such a way that the call station can be discovered and reached by the system controller. Configuration of the call station and its extensions is done via the system controller. For configuration, the call station is identified by its hostname, which is printed on the product label on the bottom of the device. The format of the hostname is the type number of the device without the dash, followed by a dash and then the last 6 hexadecimal digits of its MAC-address.



#### Notice!

A separate label is delivered with the PRA-CSBK, that contains the MAC address and the host name. Affix this label on the final product, in which the PRA-CSBK is used, so it remains readable. This information is needed during system configuration.

Configuration is described in the PRAESENSA configuration manual.

### 16.5.10 Line input

The board has a 3.5 mm stereo socket. This is an input for a background music source, such as a dedicated audio player, smartphone or PC. The stereo signal is converted to mono for further distribution in the system. This input needs to be configured in the system for this function, to link it to a background music channel that is available for playback in one or more system zones. This input is not supervised, unplugging the cable to the audio player will not be reported as a fault.



#### Caution!

The line input socket is a very vulnerable connector because it is not mechanically secured by an enclosure. Only use with flexible cables and proper cable fixation.

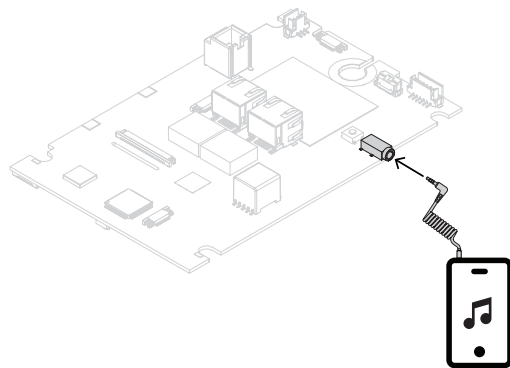

**Notice!**

When music is played from a PC that is connected to a grounded mains supply, there is a risk of hum being inserted into the music input of the call station. This is caused by unequal ground potentials of the different mains supplies. Use a cable with integrated transformers for ground loop isolation to prevent such hum. See picture below of an example ground loop isolator cable.



**Notice!**

For compliance to DNV GL type approval, the line input must not be used. By connecting a cable to this input the radiated emission of the device would exceed the limit for the maritime radio band.



**16.5.11**

**Reset to factory default**

The reset switch resets the device to its factory default settings. This function is only to be used in case a secured device is removed from a system to become part of another system. See *Device status and reset*, page 71.

In case the final product that uses the PRA-CSBK may be part of different systems, make sure that the reset switch remains accessible and is not covered by e.g. the user interface panel.

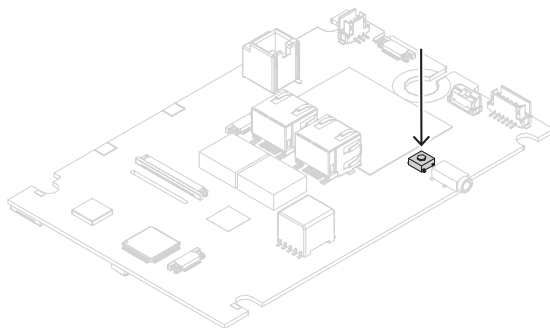



## 16.6

## Approvals

Regulatory areas	
Environment	EN/IEC 63000

## 16.7

## Technical data

## Electrical

Microphone	
Nominal acoustic input level (configurable)	89 – 109 dBSPL
Maximum acoustic input level	120 dBSPL
Minimum signal-to-noise ratio	73 dBA
Self noise	< 28 dBSPL
Directivity	Omni-directional
Frequency response (+3 / -6 dB)	500 Hz – 8 kHz (noise cancelling)
Cable length (stretched)	300 cm

Monitor loudspeaker	
Maximum sound pressure level, at 1 m	75 dBSPL
Volume notification buzzer	0 dB
Volume message monitoring	-20 dB
Frequency range (-10 dB)	400 Hz – 10 kHz

Line input	
Minimum signal-to-noise ratio	> 96 dBA
Frequency response (-3 dB)	20 Hz – 20 kHz
Total harmonic distortion + noise	< 0.1%

Power transfer	
Power over Ethernet (PoE 1-2) Nominal DC input voltage Standard	48 V IEEE 802.3af Class 3
Power consumption Call station (business use) Call station (emergency use) Call station extension (via RJ12)	3.2 W 4.4 W 5 W maximum
Input voltage tolerance	37 – 57 VDC

Supervision	
Supervision Microphone Audio path	Impedance Pilot tone

<b>Supervision</b>	
Press-to-talk switch Controller continuity PoE (1-2)	Impedance Watchdog Voltage
<b>Network interface</b>	
Ethernet  Protocol Redundancy	100BASE-TX, 1000BASE-T  TCP/IP RSTP
Audio/control protocol Network audio latency Audio data encryption Control data security	OMNEO 10 ms AES128 TLS
Ports	2
<b>Reliability</b>	
MTBF (extrapolated from calculated MTBF of PRA-CSLD and PRA-CSLW)	1,000,000 h
<b>Environmental</b>	
<b>Climatic conditions</b>	
Temperature Operating  Storage and transport	-5 – 45 °C (23 – 113 °F)  -30 – 70 °C (-22 – 158 °F)
Humidity (non-condensing)	5 – 95%
Air pressure (operating)	560 – 1070 hPa
Altitude (operating)	-500 – 5000 m (-1640 – 16404 ft)
Vibration (operating) Amplitude Acceleration	< 0.35 mm < 5 G
Bump (transport)	< 10 G (IEC 60068-2-27)

**Mechanical**

<b>Enclosure (PRA-CSLW)</b>	
Dimensions (HxWxD)	20 x 110 x 162 mm (0.8 x 4.3 x 6.4 in)
Weight (excluding accessories)	120 g (0.26 lb)

## 17 Call station extension kit (CSEK)

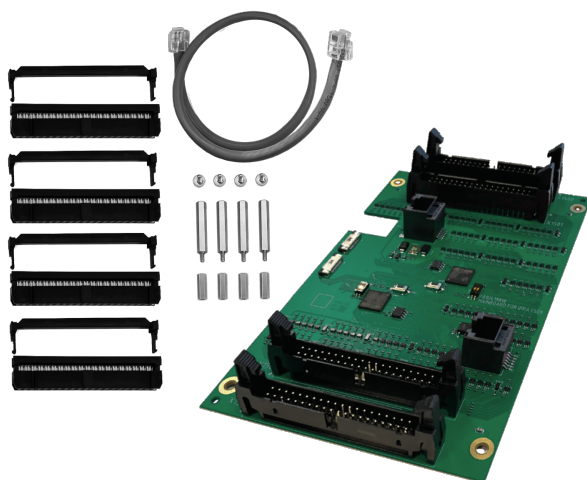

### 17.1 Introduction

The call station extension kit is an open frame call station extension to create dedicated full custom operator panels for PRAESENSA public address systems. The extension kit connects to the basic call station kit PRA-CSBK, offering the same functionalities as two PRA-CSE devices without the integrated switches and indicators.

The extension kit has a CAN-bus interface on RJ12 to the PRA-CSBK, which is also used for power. A second RJ12-connection allows for loop-through to a another PRA-CSEK. Each PRA-CSEK accepts up to 24 external selection switches and the associated status LEDs. Up to five status LEDs can be connected for each switch. These LEDs are similar to what the PRA-CSE provides for each key.

The PRA-CSEK is considered a component that must be installed in a final product. The final product must be reconfirmed to meet the applicable EMC directives.

### 17.2 Functions

#### Business operation

- One or two PRA-CSEK extension kits can be connected to a PRA-CSBK, each with connections for up to 24 switches that can be configured for various functions. The switches are especially useful for zone selection on a synoptic panel, giving a clear overview of the accessible zones and their location. The LED indicators for each switch show the status of the respective zone, such as selected, occupied or at fault.
- The PRA-CSEK is intended for the PRA-CSBK, but it can also be used with a PRA-CSLD, a PRA-CSLW, as well as one or two PRA-CSE.
- Each PRA-CSEK is configured as two PRA-CSE extensions, the first one for switches 1-12 and 13-24 and a second one for switches 25-36 and 37-48.
- The call station extension kit can also be used to create full custom emergency panels with all required functionalities. However, the PRA-CSBK and PRA-CSEK are components of a final product and, as such, cannot be certified for voice alarm purposes. The final product must be reconfirmed to meet the applicable voice alarm standards, or must be certified on a project basis by the Authorities Having Jurisdiction.
- All the indicators connected to the extension kit are part of the indicator test function of the connected call station kit.

**Connection**

- External switches and associated indicators can be connected to the PRA-CSEK in sets of six through a 40-way ribbon cable with lockable IDC-connector (Insulation Displacement Connector). The connector uses a two-row pin spacing of 2.54 mm (0.1 in). The ribbon cable uses a wire spacing of 1.27 mm (0.05 in).
- The PRA-CSEK is powered from the PRA-CSBK through a 6-pin RJ12-interconnection cable that also serves for CAN-bus data transfer. A second RJ12 connector loops-through to a subsequent PRA-CSEK.

**Note:** The total maximum length of the CAN-bus cabling must not exceed 1.5 meters (59.06 inches).

- The extension kits are automatically addressed. The first one is connected to the PRA-CSBK for switches 1-24. The second one is connected to the first extension kit for switches 25-48.

**Mounting**

- The first PRA-CSEK can be mounted on top of the PRA-CSBK, with the second PRA-CSEK mounted on top of the first. Mounting accessories for stack-mounting are included. The kits can also be mounted side-by-side with the same included RJ12-cable.
- Due to the high number of interconnections, it is strongly advised to mount the switches and the LED indicators on a PCB of the required size with shrouded pin headers (2 x 20), like the ones used on the PRA-CSEK. A standard 40-way ribbon cable can be used for the interconnection.

## 17.3 Functional diagram

Functional and connection diagram

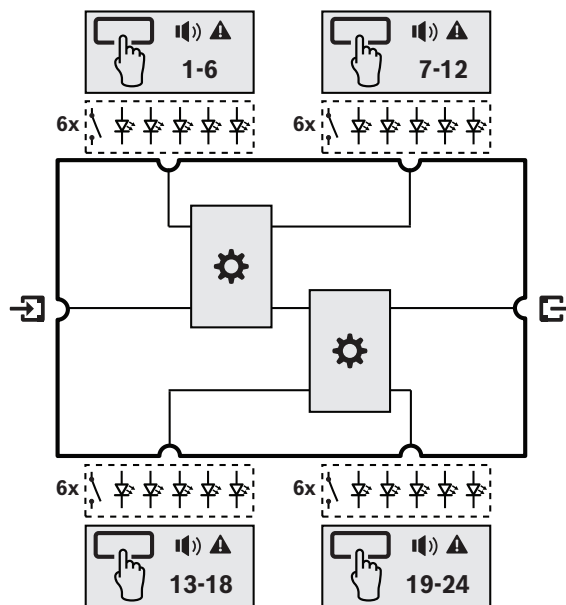



**Internal device functions**

- Controller
- Zone status indicator
- Zone fault indicator

## 17.4 Indicators and connections

**Top side interconnections**

	Input connection (RJ12) from PRA-CSBK or previous PRA-CSEK		Output connection (RJ12) to subsequent PRA-CSEK	
--	--	--	---	--

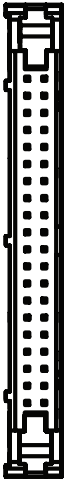
 	Connection to switches and indicators for zone/function 1-6 / 7-12 / 13-18 / 19-24: - White: Selection - Red: Evacuation call - Blue: Business call - Green: Music - Yellow: Zone fault				
--	--	---	--	--	--

## 17.5

### Installation

#### 17.5.1

#### Parts included

The box contains the following parts:

Quantity	Component
1	Call station extension kit
4	2 x 20-pin IDC connectors for ribbon cable
1	RJ12 interconnection cable
4	Mounting studs, M3 x 35 mm
4	Mounting inserts, M3 x 14 mm
4	Screws M3 x 8 mm, Tx10
1	Quick installation guide
1	Safety and security information

No tools or Ethernet cables are provided with the device.

#### Parts check and identification

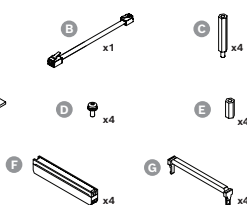
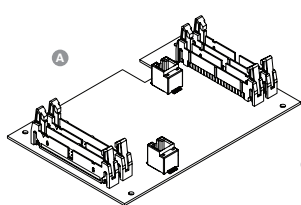

- A** Call station extension kit
- B** RJ12 interconnection cable
- C** Mounting studs, M3 x 35 mm
- D** Screws M3 x 8 mm, Tx10
- E** Mounting inserts, M3 x 14 mm
- F** Ribbon cable connector 2x20
- G** Strain relief for connector

#### 17.5.2

#### Enclosure requirements

The PRA-CSEK is used in combination with the PRA-CSBK. All enclosure requirements for the PRA-CSBK as stated in *Enclosure requirements*, page 215 also apply to the PRA-CSEK.

### 17.5.3

#### Mounting

Depending on available space in the enclosure, you can mount the PRA-CSEK:

- Vertically, on top of the PRA-CSBK, or
- Horizontally, next to the PRA-CSBK.

Optionally, you can mount a second PRA-CSEK on top of the first PRA-CSEK, or next to it.

The position of the mounting holes corresponds to the 95 mm x 136 mm rectangular pattern of the PRA-CSBK.

#### Refer to

- *Vertical mounting, page 231*
- *Horizontal mounting, page 232*

### 17.5.4

#### Vertical mounting

For vertical mounting with the PRA-CSBK mounted on a flat plate or frame and the PRA-CSEK on top of it, do the following:

1. Mount the PRA-CSBK with its isolated mounting grommets F in the slots.
  - Refer to the *Parts included, page 214* of the PRA-CSBK for details on the isolated mounting grommets F.
2. Screw a 35 mm mounting stud C from the top side into a 14 mm mounting insert E at the bottom side of the PRA-CSBK, with the mounting grommet in between.
  - Parts C and E are packed with the PRA-CSEK, but now used for the PRA-CSBK.
3. Repeat the previous step for the four mounting holes.
4. Mount the PRA-CSEK on the studs C with the screws D.
5. Plug the RJ12 connectors of the reversible interconnection cable B into the output socket of the PRA-CSBK and into the input socket of the PRA-CSEK.
6. Mount the stacked boards on a flat mounting plate with M3 screws into the studs E.
  - The length of these screws depends on the thickness of the mounting plate.

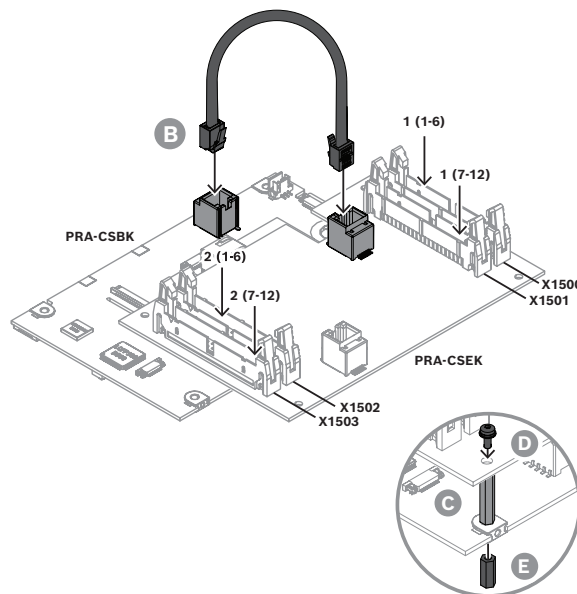

### Mount a second PRA-CSEK on top of the first

Before mounting the second PRA-CSEK, insert the appropriate ribbon cables with IDC connectors into the shrouded pin headers X1500 - X1503 of the first PRA-CSEK. Otherwise, the second PRA-CSEK prevents the access to these headers. Refer to *Crimp the ribbon cables into the IDC connector*, page 233 and further.

1. Use the studs C of the second PRA-CSEK to fix the first PRA-CSEK on the studs C of the first PRA-CSEK.
2. Rotate the second PRA-CSEK 180 degrees in comparison with the first board.
3. Mount the second PRA-CSEK, now in the opposite direction to first, on the second set of studs C with the screws D.
4. Plug the RJ12 connectors of the reversible interconnection cable B into the output socket of the first PRA-CSEK and into the input socket of the second PRA-CSEK.
5. Mount the stacked boards on a flat surface or on a mounting plate, as shown before.

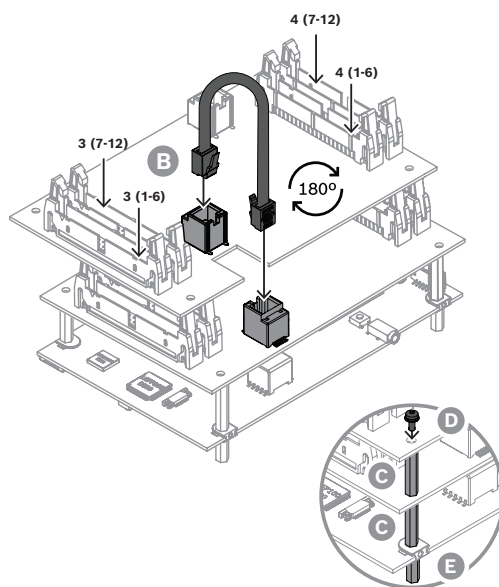

## 17.5.5

### Horizontal mounting

For horizontal mounting with the PRA-CSBK mounted on a flat plate or frame and the PRA-CSEK next to it, do the following:

1. Mount the PRA-CSBK with its isolated mounting studs G in the slots. Refer to the *PRA-CSBK Mounting*, page 215.
  - Refer to the *Parts included*, page 214 of the PRA-CSBK for details on the isolated mounting studs G.
2. Use the plastic mounting studs with the long end down to make the mounting height of the PRA-CSBK the same as the mounting height of the PRA-CSEK.
3. Mount the PRA-CSEK next to the PRA-CSBK with the M3 x 14 inserts E and screws D.
4. Plug the RJ12 connectors of the reversible interconnection cable B into the output socket of the PRA-CSBK and into the input socket of the PRA-CSEK.

### Mount a second PRA-CSEK next to the first

1. Rotate the second PRA-CSEK 180 degrees in comparison with the first board.
2. Mount the second PRA-CSEK next to the first PRA-CSEK with the M3 x 14 inserts E and screws D.



3. Plug the RJ12 connectors of the reversible interconnection cable B into the output socket of the first PRA-CSEK and into the input socket of the second PRA-CSEK.

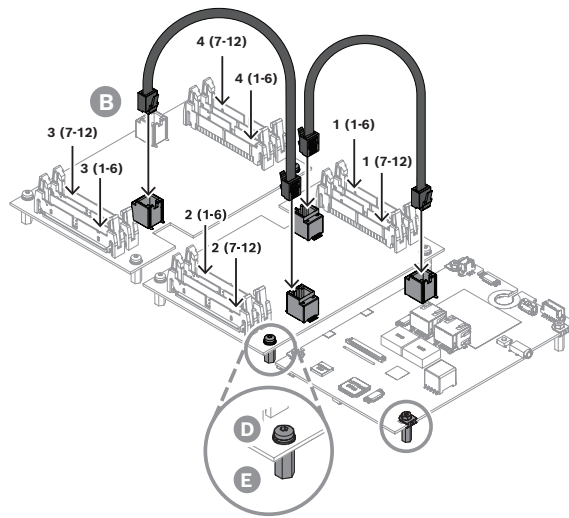

### 17.5.6

#### Crimp the ribbon cables into the IDC connector

The switches and LED indicators are connected through ribbon cables. Typically, the switches and LEDs are placed on a custom-made Printed Circuit Board (PCB). The ribbon cables connect that custom PCB to the PRA-CSEK.

Use standard 40-wire ribbon cables of the sufficient length with a wire spacing of 1.27 mm (0.05 in). Typically, the ribbon cable is gray or light blue. The wire for the pin 1 has a different color, often red or dark blue. The assembly of the connector to the ribbon cables is as follows:

1. Insert the cable into connector F, with wire 1 going to the pin-socket 1.
  - The polarizing tab in the middle of the connector ensures the correct orientation when used with the shrouded header on the PRA-CSEK. When you insert the cable, the polarizing tab must be on the other side of the connector.
2. Press the two parts of the connector together with a dedicated tool that crimps the ribbon cable into the IDC connector.
  - If a dedicated tool is not available, you can use a small bench vise or an arbor press to crimp reliably the connector onto the cable.
  - The insulation displacement (IDC) contacts on the connector allows the two parts of the connector to be easily crimped onto the flat ribbon cable.
3. Fold the ribbon cable over the connector.
4. Press the ribbon cable strain relief over the ribbon cable until it snaps in place.

With the connector upside down, the polarizing tab of the connector should now be on the side of the ribbon cable. In the graphic, pin 1 and wire 1 have a dark color.

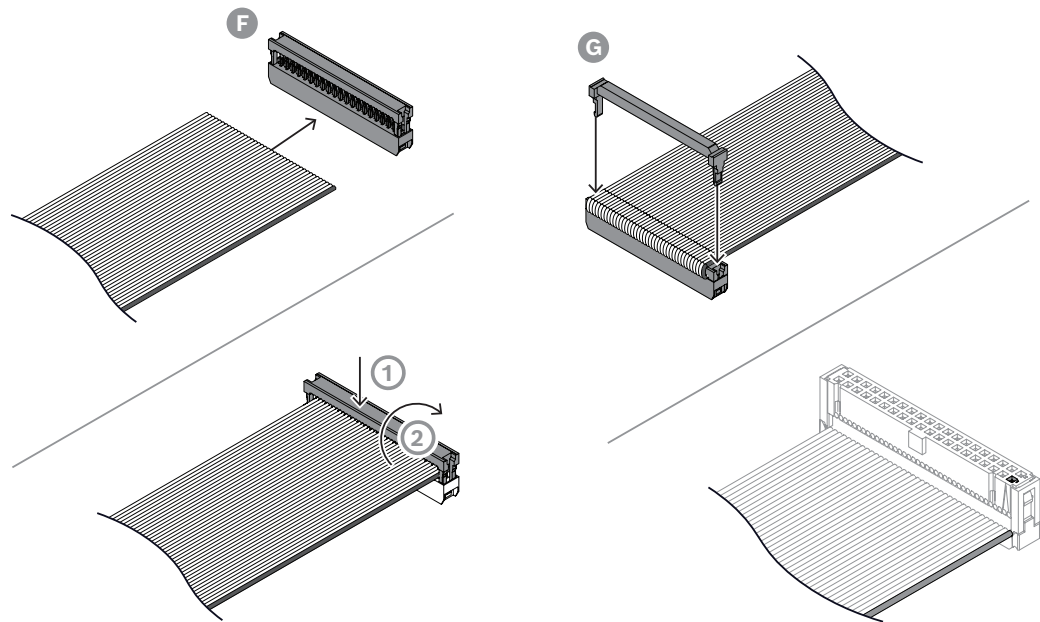

### 17.5.7

#### Insert the IDC connectors

You must insert the IDC connectors with ribbon cables in the correct order into the shrouded pin headers X1500 - X1503. Proceed as follows:

1. Find the correct pin header. The pin header numbers are shown on the PCB and indicated in the graphic.
  - The pin header X1500 is for switches 1 - 6. These switches are configured as switches 1-6 of the first call station extension. Each PRA-CSEK represents two PRA-CSE devices and is configured as such. For that reason, these switches are indicated as 1 (1-6).
  - The pin header X1501 is for switches 7-12 of the first call station extension in the configuration. For that reason, these switches are indicated as 1 (7-12).
  - The pin header X1502 is for switches 1-6 of the second call station extension in the configuration. For that reason, these switches are indicated as 2 (1-6).
  - The pin header X1503 is for switches 7-12 of the second call station extension in the configuration. For that reason, these switches are indicated as 2 (7-12).
2. Plug the IDC connectors into the shrouded headers in the order X1500, X1501, X1503 and finally X1502, as shown in the graphic.

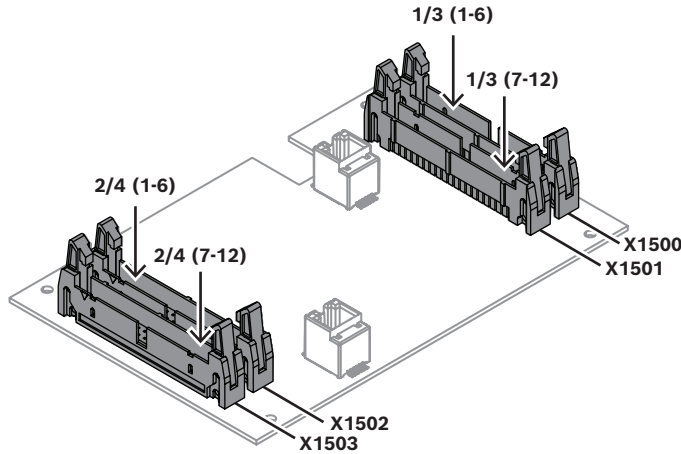

If a second PRA-CSEK is used, the ribbon cables with connectors are connected in a similar way. The second PRA-CSEK is configured as a combination of a third and fourth PRA-CSE:

- X1500 is for 3 (1-6).
- X1501 is for 3 (7-12).
- X1502 is for 4 (1-6).
- X1503 is for 4 (7-12).

Since the second PRA-CSEK rotates 180 degrees compared to the first one, the cables for 3 (1-6) and 3 (7-12) run in the same direction as 2 (1-6) and 2 (7-12). Likewise, the cables for 4 (1-6) and 4 (7-12) run in the same direction as 1 (1-6) and 1 (7-12).

Note that the connectors for 1 (1-6), 2 (7-12), 3 (1-6) and 4 (7-12) are on the outside edge of the PCB.

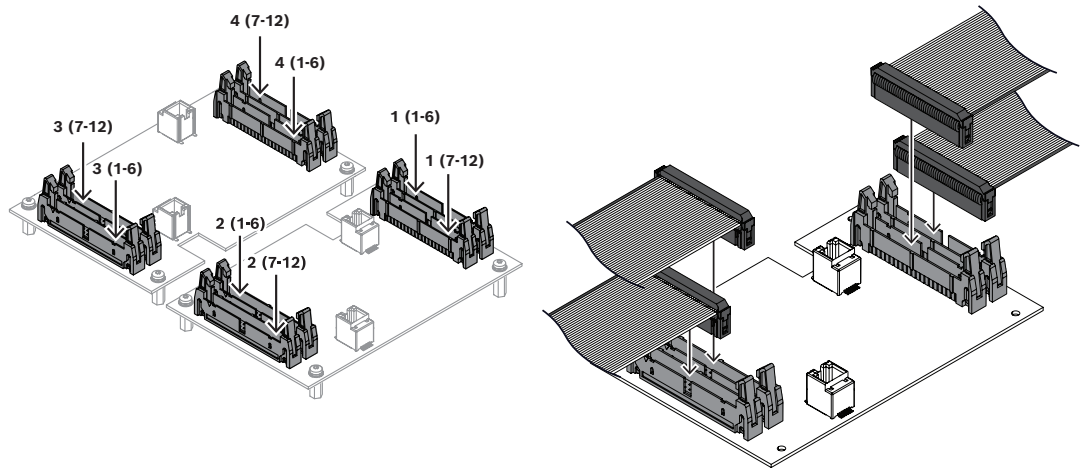

### 17.5.8 Pin assignment of the connectors

The graphic shows the pin assignment of the connectors X1500 - X1503. In this graphic, the odd pins 1 - 39 are on the left side and the even pins 2-40 are on the right side. The pin 1 is top left, the pin 40 is bottom right.

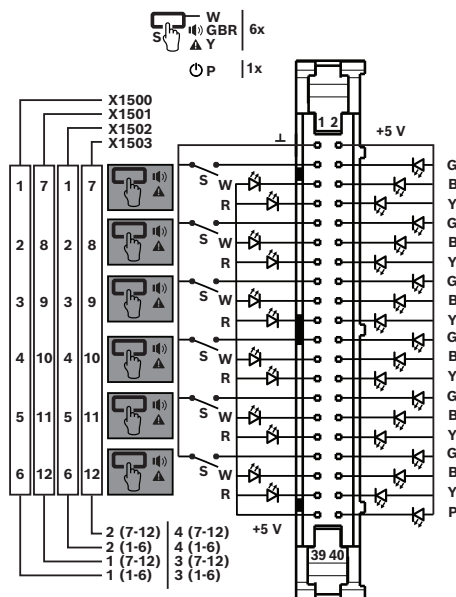

You can connect up to 24 switches with five LEDs per switch to one PRA-CSEK, the equivalent of two PRA-CSE devices. Each connector provides the connections for six switches with 6 x 5 status LEDs and one power LED. The power LED can be used to give ambient light on the panel. All LEDs, including the power LED, are dimmable. The table presents the same pin assignment as the circuit diagram. A second PRA-CSEK would use the same table, but for Extension 3 and Extension 4.





Pin	Extension 1		Extension 2	
	X1500	X1501	X1502	X1503
1	Ground	Ground	Ground	Ground
2	+5 V	+5 V	+5 V	+5 V
3	Switch 1	Switch 7	Switch 1	Switch 7
4	Green LED 1	Green LED 7	Green LED 1	Green LED 7
5	White LED 1	White LED 7	White LED 1	White LED 7
6	Blue LED 1	Blue LED 7	Blue LED 1	Blue LED 7
7	Red LED 1	Red LED 7	Red LED 1	Red LED 7
8	Yellow LED 1	Yellow LED 7	Yellow LED 1	Yellow LED 7
9	Switch 2	Switch 8	Switch 2	Switch 8
10	Green LED 2	Green LED 8	Green LED 2	Green LED 8
11	White LED 2	White LED 8	White LED 2	White LED 8
12	Blue LED 2	Blue LED 8	Blue LED 2	Blue LED 8
13	Red LED 2	Red LED 8	Red LED 2	Red LED 8
14	Yellow LED 2	Yellow LED 8	Yellow LED 2	Yellow LED 8

	Extension 1		Extension 2	
15	Switch 3	Switch 9	Switch 3	Switch 9
16	Green LED 3	Green LED 9	Green LED 3	Green LED 9
17	White LED 3	White LED 9	White LED 3	White LED 9
18	Blue LED 3	Blue LED 9	Blue LED 3	Blue LED 9
19	Red LED 3	Red LED 9	Red LED 3	Red LED 9
20	Yellow LED 3	Yellow LED 9	Yellow LED 3	Yellow LED 9
21	Switch 4	Switch 10	Switch 4	Switch 10
22	Green LED 4	Green LED 10	Green LED 4	Green LED 10
23	White LED 4	White LED 10	White LED 4	White LED 10
24	Blue LED 4	Blue LED 10	Blue LED 4	Blue LED 10
25	Red LED 4	Red LED 10	Red LED 4	Red LED 10
26	Yellow LED 4	Yellow LED 10	Yellow LED 4	Yellow LED 10
27	Switch 5	Switch 11	Switch 5	Switch 11
28	Green LED 5	Green LED 11	Green LED 5	Green LED 11
29	White LED 5	White LED 11	White LED 5	White LED 11
30	Blue LED 5	Blue LED 11	Blue LED 5	Blue LED 11
31	Red LED 5	Red LED 11	Red LED 5	Red LED 11
32	Yellow LED 5	Yellow LED 11	Yellow LED 5	Yellow LED 11
33	Switch 6	Switch 12	Switch 6	Switch 12
34	Green LED 6	Green LED 12	Green LED 6	Green LED 12
35	White LED 6	White LED 12	White LED 6	White LED 12
36	Blue LED 6	Blue LED 12	Blue LED 6	Blue LED 12
37	Red LED 6	Red LED 12	Red LED 6	Red LED 12
38	Yellow LED 6	Yellow LED 12	Yellow LED 6	Yellow LED 12
39	+5 V	+5 V	+5 V	+5 V
40	Power LED	Power LED	Power LED	Power LED

The Ground connection is the common connection for the switches. The +5 V connection is the common connection for the anode of the LEDs. All LEDs are current controlled with an accurate current sink of 4 mA per output at maximum brightness. A series resistor is not needed to limit the LED current. The LEDs can be dimmed in multiple steps, using Pulse Width Modulation (PWM).

The PRA-CSEK is powered from the PRA-CSBK to which it is connected, while the PRA-CSBK is powered through PoE. Do not use any other power supplies. Keep each set of up to six switches and up to 31 LEDs that are connected to the same connector separated from the switches and the LEDs that are connected to another connector. Do not interconnect ground and +5 V connections from different connectors.

The LED colors represent the same LED function as the PRA-CSE :

	Selection button LED Selected	White (W)		Active Evacuation call Business call Music	Red (R) Blue (B) Green (G)
	Zone fault present	Yellow (Y)		Power/ambient light	User selectable

## 17.6

### Approvals

Regulatory areas	
Environment	EN/IEC 63000

## 17.7

### Technical data

#### Electrical

Power transfer	
Input voltage (VDC)	5 VDC
Input voltage (VDC) (tolerance)	4.5 VDC – 5.5 VDC
Power consumption (W) (indicators on / off)	2 W / 0.2 W

#### Supervision

Interconnection	Link presence
Protection (processor)	Watchdog

#### Environmental

Operating temperature (°C)	-5 °C – 50 °C
Operating temperature (°F)	23 °F – 122 °F
Storage temperature (°C)	-30 °C – 70 °C
Storage temperature (°F)	-22 °F – 158 °F
Operating relative humidity, non-condensing (%)	5% – 95%
Installation altitude (m)	-500 m – 5,000 m
Installation altitude (ft)	-1,640 ft – 16,404 ft
Operating vibration	
Amplitude (mm)	< 0.35 mm
Acceleration (G)	< 5 G

Bump (transport) (G)	< 10 G (IEC 60068-2-27)
----------------------	-------------------------

**Mechanical**

Dimensions (H x W x D) (mm)	158 mm x 105 mm x 32 mm
Dimensions (H x W x D) (in)	6.22 in x 4.13 in x 1.26 in
Weight (g)	105 g
Weight (lb)	0.23 lb

## 18 Wall control panel (WCP-EU, WCP-US)



### 18.1 Introduction

The wall control panel PRA-WCP provides convenient local control of background music (BGM) in a zone covered by a PRAESENSA sound system. In the PRAESENSA system it is possible to configure a set of selectable music sources, the volume control range, and the operating zone for each wall control panel. Control is quick and intuitive, with a single knob for the rotate and push select actions. The color LCD provides clear user feedback. It is possible to manage user access with a PIN to restrict operation to authorized staff.

The PRA-WCP-EU comes with a white front, knob and square wall plate. A black front, knob and wall plate are included for easy exchange on-site. It fits in the standard European round recess electrical back box for flush-mount installation.

The PRA-WCP-US comes with a white front and a knob. A black front and knob are included for easy exchange on-site. It fits in a standard rectangular US single-gang wall-mount box for flush-mount installation. The panel must be covered with a standard Decora wall plate.

### 18.2 Functions

#### IP-network connection

- Direct connection to the IP-network. One shielded Ethernet cable is sufficient for Power over Ethernet and data exchange.
- The wall control panel communicates the BGM settings directly to the system controller. The system controller adjusts the source and level of the involved amplifier channels accordingly.
- Because only control information is exchanged, no audio data, the occupied network bandwidth for this function is minimized.

#### Operation

- The volume settings of the BGM have configurable minimum and maximum levels.
- Selection of the BGM source from a list of BGM channels that are assigned to the zone under control.
- Selection through a single rotary knob with push action.
- Clear user feedback through the backlit color LCD.
- Optional access control through PIN entry to restrict operation to authorized staff.



**Installation**

- The PRA-WCP-EU fits in a standard European round recess electrical back box for flush-mount installation with 60 mm of inside diameter and 60 mm of depth. Square wall plates (white and black) are included.
- The PRA-WCP-US fits in a standard rectangular US single-gang wall-mount box with a depth of 50 mm or 2 inches. To match already installed switches and sockets, the wall control front panel can be covered with a standard Decora wall plate with a cutout of 1.375 in x 2.75 in (not included).
- IP-network connection through a single cable with RJ45 connector.
- The device comes with a black and a white front cover and wall plate, exchangeable to match the environment.

**18.3**

**Functional diagram**

**Functional and connection diagram**

**Internal device functions**

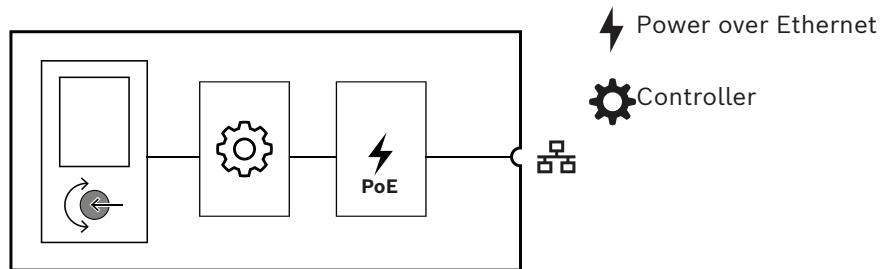

# 18.4

## Dimensions

PRA-WCP-EU Wall control panel, EU-style

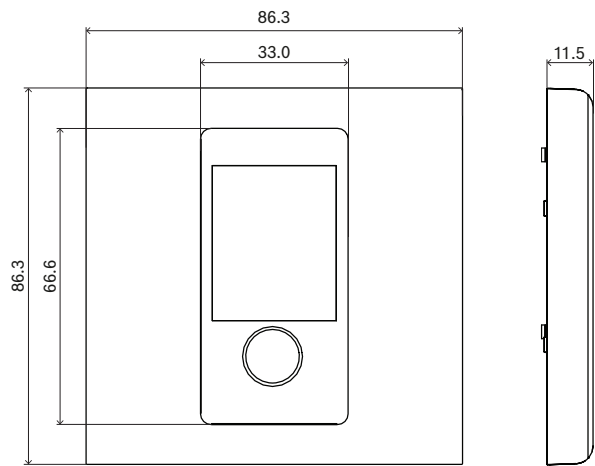
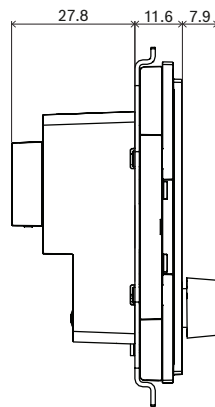
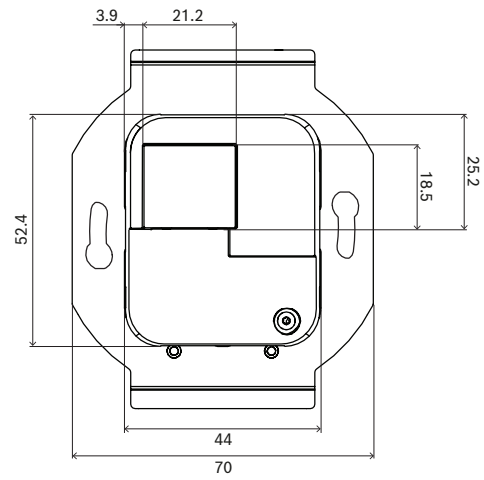
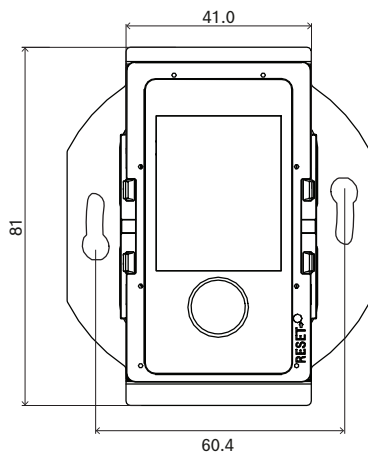

mm

**PRA-WCP-US Wall control panel, US-style**

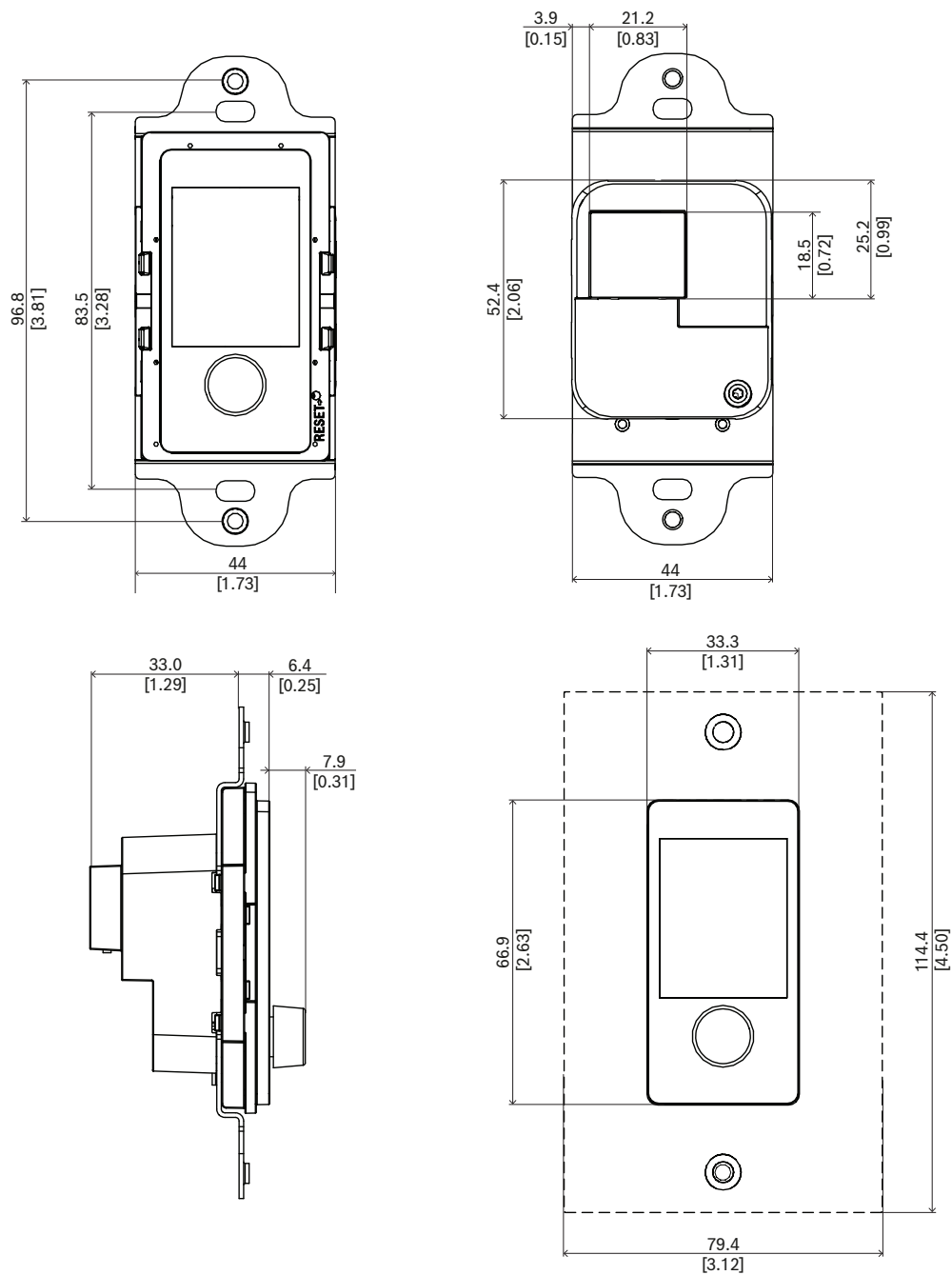

mm [in]

## 18.5 Indicators and connections



### Front panel indicators and controls

	Status screen	LCD		Function select and control	Rotary /push encoder
	Device reset to factory default	Button (behind the cover)			



### Rear side indicators and interconnection

	100 Mbps network 1-2 1 Gbps network 1-2	Yellow Green		Network port (PoE PD)	
--	--	-----------------	--	-----------------------	--

## 18.6 Installation

The device is designed to be installed in a standard electrical back box or in a wall-mount box:

- The PRA-WCP-EU in a round European-style box. This device comes with matching white and black square wall plates because there is no common European standard for these wall plates.
- The PRA-WCP-US in a rectangular American-style box. This device PRA-WCP-US comes without wall plates, because the standard Decora size wall plates with a cutout of 1.375 inches x 2.75 inches can be used.

The PRA-WCP can be connected everywhere within the PRAESENSA system but needs PoE for power.

### 18.6.1 Parts included

The box of the PRA-WCP-EU contains the following parts:

Quantity	Component
1	Wall control panel, white
1	Wall plate, white
1	Front cover, black
1	Knob, black
1	Wall plate, black
1	Quick installation guide
1	Safety and security information

The box of the PRA-WCP-US contains the following parts:

Quantity	Component
1	Wall control panel, white
1	Front cover, black
1	Knob, black
1	Quick installation guide
1	Safety and security information

No tools or Ethernet cables are provided with the device.

#### Parts check and identification

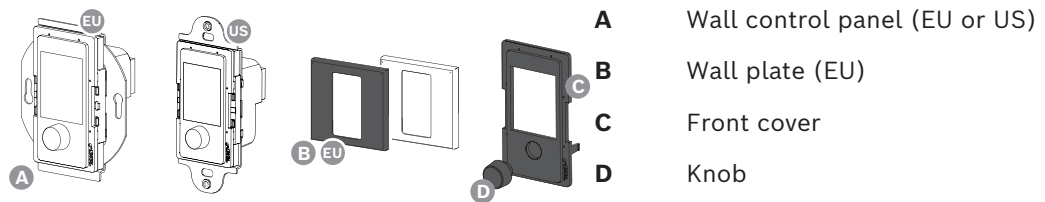

### 18.6.2 Power over Ethernet

The wall control panel is a PoE Powered Device (PD) with one PoE Ethernet connection port. It provides the correct signature and classification to the power sourcing equipment (PSE), so that a PSE sources the right amount of power to a PD over the Ethernet cables. For best availability, connect the port to a PSE with battery backup power, such as the Ethernet ports 1 or 2 of the multifunction power supply PRA-MPS3. It is also possible to connect to one of the ports 1 - 8 of the Ethernet switch PRA-ES8P2S. Since the PRA-WCP only has one Ethernet port, it is impossible to make a loop through connection to another device.

### 18.6.3 Ethernet network

The network must be set up so that the system controller can discover and reach the wall control panel for configuration. The control panel is identified by its hostname, which is printed on the product label on the rear of the device. The format of the hostname is the type number of the device without the dash, followed by a dash and then the last 6 hexadecimal digits of its MAC address. The configuration is described in the PRAESENSA Configuration manual.

Connect the control panel to the network with shielded Gb-Ethernet cables, preferably CAT6A, with RJ45 connectors. Because the panel is typically mounted in a wall-mount box, in most cases the RJ45 connector must be installed in the field. Choose a small RJ45 connector model to fit into the box.

### 18.6.4 Change the front color of the device

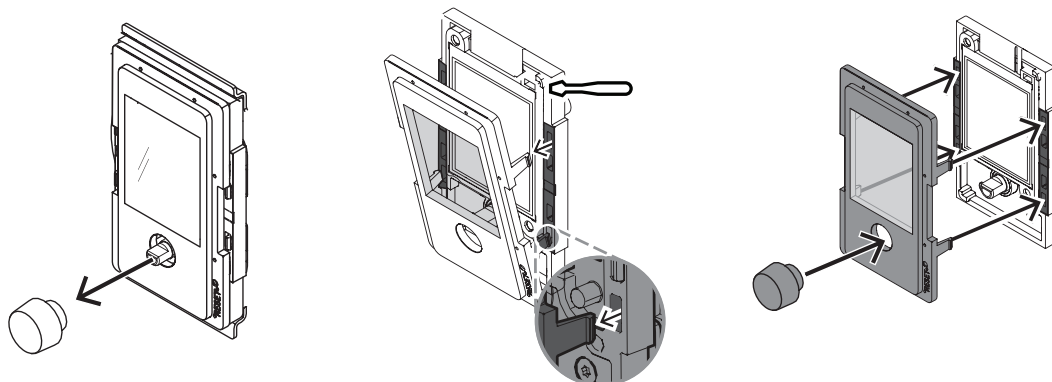

The wall control panel comes with a white front panel and knob which can easily be changed into black. A black front panel (C) and knob (D) are included.

To change the color:

1. Pull the white knob off.
2. Snap the white front panel off. Be careful not to break the snap hooks.
3. Snap the black front panel on.
4. Push the black knob on.

### 18.6.5 Wall mounting

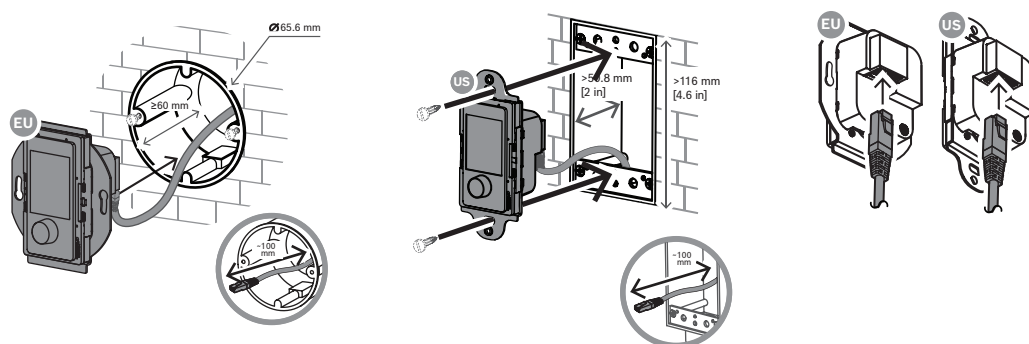

To surface-mount on a wall:

1. Use a standard in-wall electrical junction box of sufficient depth.
2. Thread the Ethernet cable in such a way it ends into the junction box.

3. Cut the cable, leaving approximately 100 mm length.
4. Install a short RJ45 connector to the cable. Use termination standard T-568A or T-568B, according to the local standard.
5. Insert the connector into the wall control panel A.
6. Mount the wall control panel vertically on the box with the screws delivered with the junction box.
7. EU version: Snap the wall plate on the device.  
US version: Use a standard Decora wall plate and bolt the wall plate in place.

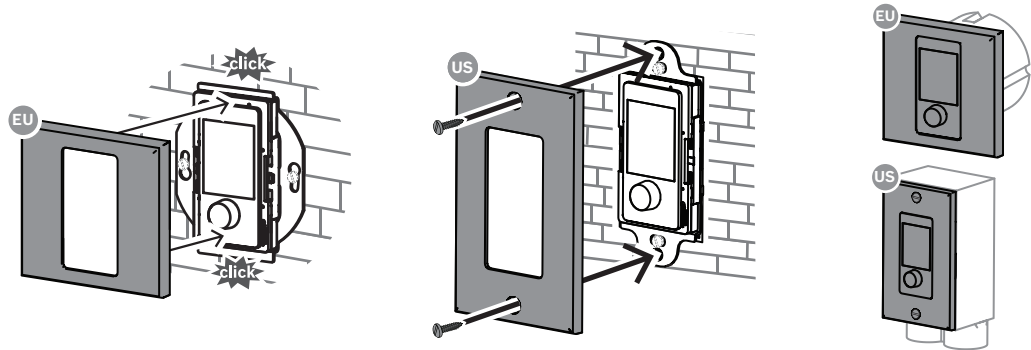

### 18.6.6

#### Operation

Operational functions of the wall control panel are software-based. New PRAESENSA software versions can add new functions.

The wall control panel provides volume control for background music in a certain zone.

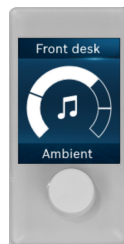

Top bar: zone that is assigned to the panel.

Middle section: volume level with markers for the minimum and the maximum volume settings for this panel.

Bottom bar: name of the selected BGM channel.

Knob: adjusts the BGM volume.

You can equip a zone with multiple wall control panels to make it possible to change the BGM from multiple locations. All panels show the selected volume level and the BGM channel. When changing the BGM, the last action is valid regardless on which panel it happens. No panel has priority over another panel.

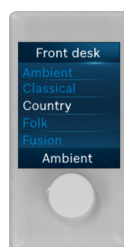

To change the active BGM channel, push the knob once briefly in a click. The source selection list appears. Rotate the knob until the desired channel is highlighted in the middle of the LCD. Press the knob again to select this channel. Until you select the new channel, the previous channel remains active and visible in the bottom bar. Scrolling through the channels list does not produce sound.

In case no music is wanted, select the empty channel in the list.

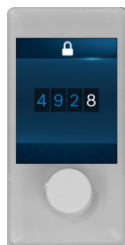

To prevent that unauthorized people adjust the background music, configure a 4-digit PIN code for access. The panel can be operated only after entering the correct PIN.

After a time out, the screen turns black to minimize screen wear out. Enter the PIN again for new access. Each panel can have its own unique PIN, or none for unrestricted access.

A long press of the knob (>5 s) opens the device information page, showing, among others, its hostname, IP-address, software version and serial number.

When naming zones and BGM channels, consider that names that are too long for the width of the LCD are clipped at the end. Zone and source names are configured in Unicode characters through the configuration web interface. Most languages are supported, except for right-to-left languages.

### 18.6.7 Reset to factory default

The hidden reset button behind the wall plate resets the device to its factory default settings. Only use this function if a secured device is removed from a system to become part of another system. Refer to *Device status and reset*, page 71.

## 18.7 Approvals

Regulatory areas	
Immunity	EN 55035
Emissions	EN 55032 EN 61000-6-3 ICES-003 ANSI C63.4 FCC-47 part 15B class A
Environment	EN/IEC 63000

## 18.8 Technical data

### Electrical

Display	
Display size (in)	1.77 in
Display color	Color
Display type	TFT
Display resolution (W x H)	128 px x 160 px
Brightness	480 cd/m <sup>2</sup>
Power transfer	
PoE input	PoE IEEE 802.3af
Nominal voltage (VDC)	48 VDC



Input voltage (VDC) (tolerance)	37 VDC – 57 VDC
Power consumption (W) (maximum)	1.30 W

**Network interface**

Ethernet type	100BASE-TX; 1000BASE-T
Protocols / standards	TCP/IP; AES70
Number of Ethernet ports	1

**Environmental**

Operating temperature (°C)	-5 °C – 50 °C
Operating temperature (°F)	-13 °F – 131 °F
Storage temperature (°C)	-30 °C – 70 °C
Storage temperature (°F)	-22 °F – 158 °F
Operating relative humidity, non-condensing (%)	5% – 95%
Air pressure (hPa)	560 hPa – 1,070 hPa
Installation altitude	-500 m – 5,000 m
Installation altitude	-1,640 ft – 16,404 ft
Operating vibration	
Amplitude	< 0.7 mm
Acceleration	< 2 G
Bump (transport)	< 10 G (IEC 60068-2-27:2008)

**Mechanical**

PRA-WCP-EU Dimensions (H x W x D) (mm)	81 mm x 70 mm x 47.3 mm
PRA-WCP-EU Dimensions (H x W x D) (in)	3.19 in x 2.76 in x 1.86 in
PRA-WCP-US Dimensions (H x W x D) (mm)	107.8 mm x 44 mm x 47.3 mm
PRA-WCP-US Dimensions (H x W x D) (in)	4.24 in x 1.73 in x 1.86 in
PRA-WCP-EU Dimensions of wall box (Ø x D) (mm)	60 mm x 60 mm
PRA-WCP-EU Dimensions of wall box (Ø x D) (in)	2.36 in x 2.36 in
PRA-WCP-US Dimensions of wall box	US single-gang with depth of 50 mm / 2 in
IP rating	IP20
Material	Plastic (PC/ABS – UL94-5VA)
Color (RAL) (front cover with knob)	RAL 9017 Traffic black; RAL 9003 Signal white
Weight (kg)	0.10 kg

Weight (lb)	0.22 lb
-------------	---------

## 19 Ethernet switch (ES8P2S)



### 19.1 Introduction

The PRA-ES8P2S is a compact, DIN-rail mounted Ethernet switch with eight Gigabit copper ports. It supports Power over Ethernet (PoE) and two Gigabit SFP combo ports. This Ethernet switch is an OEM switch, made for Bosch by Advantech for use in Bosch Public Address and Voice Alarm systems. It is a preconfigured version of the EKI-7710G-2CP-AE switch, optimized for PRAESENSA. The PRA-ES8P2S is certified for EN 54-16 in combination with PRAESENSA systems. It can be used in addition to the switch ports of the PRAESENSA system controller and multifunction power supply. This is especially convenient in large systems where more SFP ports are needed for long distance interconnections on glass fiber or more PoE-enabled ports are needed to power PRAESENSA call stations.

### 19.2 Functions

#### Intended for PA/VA systems

- Managed industrial Gigabit Ethernet switch with convection cooling and DIN-rail mounting, designed for long term continuous operation.
- Redundant wide range DC power input.
- Protected against overloads and short circuits.
- Comes with pre-installed and pre-configured firmware for quick installation and optimum performance.
- Certified for EN 54-16 in combination with Bosch PRAESENSA systems.

#### Advanced features

- Managed switch, configurable via web browser, with eight Gigabit copper ports with PoE and two SFP combo ports for PRA-SFPLX single mode and/or PRA-SFPSX multimode fiber transceiver modules.
- Deactivated Energy Efficient Ethernet (EEE) mode on all ports to avoid problems in combination with audio clock synchronization (IEEE 1588) in combination with OMNEO, Dante and AES67.
- Wire speed switching in hardware to avoid variable latency that may cause audio streaming problems.

- Full Quality of Service (QoS) through differentiated services (DiffServ) on all ports, compatible with OMNEO Docent diagnostic tool.
- Support for Rapid Spanning Tree Protocol (RSTP) according to IEEE 802.1d to create redundant loops.
- Fault output relay for fault reporting into PA/VA system.
- Large MAC-address table (8k-addresses) for large system broadcasting.
- Support for Simple Network Management Protocol (SNMP) and Link Layer Discovery Protocol (LLDP).
- All copper ports provide PoE (IEEE 802.3 af/at) to power PRAESENSA call stations or other devices.

**Fault tolerance**



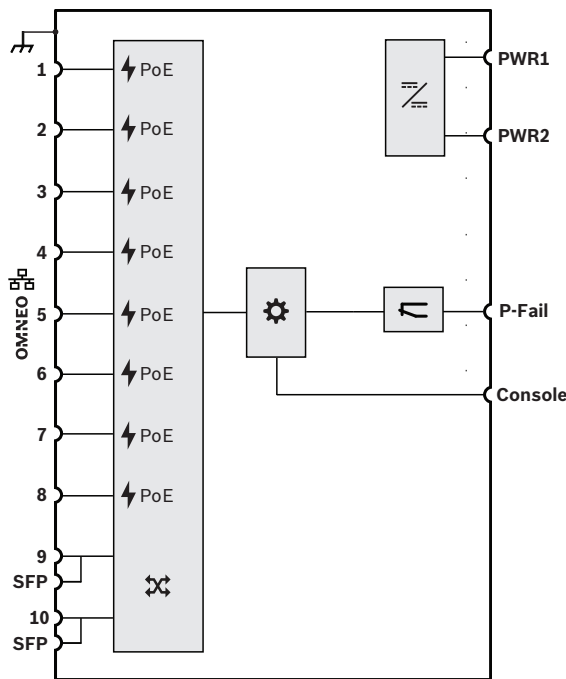

- All ports support RSTP for loop connections to adjacent devices with recovery from a broken link.
- Dual redundant 24 to 48 V DC-inputs.

### 19.3 Functional diagram

**Functional and connection diagram**



**Internal device functions**

-  Power over Ethernet power source
-  OMNEO network switch
- SFP** Socket for SFP module
-  Controller
-  DC to DC converter
-  Fault relay

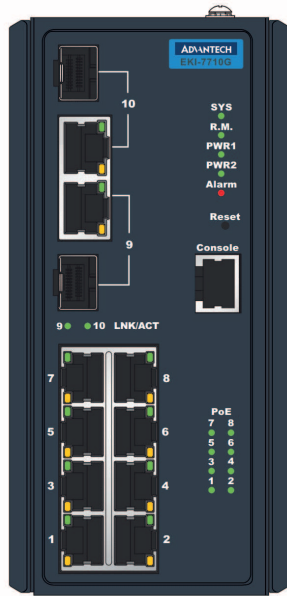

# 19.4 Indicators and connections



## Front panel indicators and controls

Port 1-10 ^	Link activity	Green	SYS	System is operating normally	Green
Port 1-10 v	100 Mbps network 1 Gbps network	Yellow Green	R.M.	Active when determining ring master	Green
-	-	-	PWR1	Power on power supply input 1	Green
PoE 1-8	PoE activated	Green	PWR2	Power on power supply input 2	Green
Reset	System soft reset or factory reset	Switch	Alarm	SFP port disconnected or link down	Red

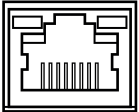
## Front panel connections

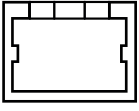
Port 1-8	Network port 1-8 with PoE		Port 9-10	Network combo port 9-10	
Console	Console serial RS232 cable COM port				

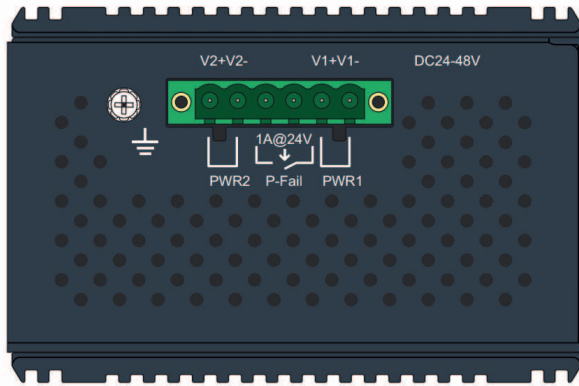

**Top panel connections**

	Chassis ground		PWR1	24 to 48 VDC input 1	
PWR2	24 to 48 VDC input 2		P-Fail	Fault relay	

**19.5**

**Installation**

The PRA-ES8P2S is a preconfigured version of the Ethernet switch from Advantech EKI-7710G-2CP-AE. Detailed installation and configuration instructions can be downloaded from the manufacturer’s website: [www.advantech.com](http://www.advantech.com). The switch can be mounted on a DIN-rail or on a wall or panel, using the wall mounting brackets.

**Notice!**

For security reasons, by default this switch is not accessible from the Internet. When the default (special link-local) IP-address is changed to an address outside the link-local range (169.254.x.x/16), then also the default (published) password must be changed. But even for applications on a closed local network, for highest security the password may still be changed. To do so:

- 1: Access the switch via its preconfigured IP address, using a browser to setup a secure connection to <https://169.254.255.1>.
- 2: The PRA-ES8P2S is factory configured with the following default credentials:  
User: Bosch.  
Password: mLqAMhQ0GU5NGUK.
- 3: Log in to this account. This is an account with administrator rights.
- 4: Change the password and if needed the IP-address, and save the password for future access.

The IP-address is only used to get access to the switch for configuration, but it is not used during operation. For that reason it is not a problem to have multiple PRA-ES8P2S switches connected on the same network, all with the same (default) IP-address. Only when the configuration is to be changed, each switch must be individually connected to the configuration PC, one at a time, to make the changes.



**Notice!**

By convention, most SNMPv1-v2c equipment ships from the factory with a read-only community string set to "public". This also applies to the PRA-ES8P2S. The SNMP community string is like a user id or password that allows access to the switch statistics. If the community string is correct, the device responds with the requested information, otherwise the device simply discards the request and does not respond. For security reasons, it is standard practice for network managers to change all the community strings to customized values in the device setup, or SNMP should be disabled.

**Notice!**

Open Source Software license agreements are accessible as download from the device itself. Access the device via its IP-address (<https://169.254.255.1> is the factory default address). No user credentials are needed for this.

**Notice!**

PRAESENSA supervises the network links between OMNEO devices, but a link between two non-OMNEO devices is not supervised. The PRA-ES8P2S is not a native OMNEO device and a connection between two of these switches is not normally supervised. From software version V1.50 onwards, the system controller (PRA-SCL / PRA-SCS) uses SNMP V3 to poll and supervise the PRA-ES8P2S switch, as well as the CISCO IE-5000-12S12P-10G switch. The controller supervises the power status, port status and unit presence. As such, the switches can be daisy-chained without an OMNEO device in between for connection supervision. The faults are reported through the system controller.

**19.5.1****Parts included**

The box contains the following parts:

Quantity	Component
1	10-port industrial Ethernet switch
1	Screw connector
2	Wall-mounting bracket
1	DIN-rail mounting bracket and screws
1	Startup manual

No tools or Ethernet cables are provided with the device.

**19.5.2****Power supply connection**

This Ethernet switch has dual redundant 24 to 48 V DC-inputs. In case no battery backup is required, it can be powered from a PRA-PSM24 or PRA-PSM48 power supply. In case the switch is used in a Voice Alarm system, compliant to EN 54-16, the switch must be powered from an EN 54-4 certified power supply, like the PRA-MPS3.

When the switch is powered by the PRA-MPS3 multifunction power supply, it must be connected to one of the 48 V outputs, normally intended for the amplifiers. Use both A and B outputs for connection redundancy. The 24 V output of the PRA-MPS3 is not powerful enough for this switch. The 48 V output that is powering the switch should not be used to also power an amplifier. Especially when the switch is serving multiple PoE powered devices as PSE (Power Sourcing Equipment), its power consumption can raise to 140 W. The remaining power capacity of the 48 V supply is not sufficient anymore for an amplifier under various load conditions.

The lifeline that belongs to the powering 48 V output is not used, so the 48 V output will not be disabled as would be for amplifiers in sleep/snooze mode to save power. It is also essential that the 48 V for the switch is not disabled at any time. In case of mains failure the switch will be powered from the battery, connected to the multifunction power supply.

### 19.5.3 Fault relay connection

The switch has a fault relay output to report faults. This relay can be connected to one of the control inputs of the PRA-MPS3, configured as 'External fault input', to transfer switch faults to the PRAESENSA system. This switch does not communicate via OMNEO to the PRAESENSA system controller.

## 19.6 Approvals

<b>Emergency standard certifications</b>	
Europe	EN 54-16 (0560-CPR-182190000)
International	ISO 7240-16
Maritime applications	DNV GL Type Approval
<b>Emergency standard compliance</b>	
Europe	EN 50849
UK	BS 5839-8
<b>Regulatory areas</b>	
Safety	EN/IEC 62368-1
Immunity	EN 55035 EN 61000-4-2 EN 61000-4-3 EN 61000-4-4 EN 61000-4-5 EN 61000-4-6 EN 61000-4-8
Emissions	EN 55032 class A EN 61000-6-4 FCC-47 part 15B class A CAN ICES-003(A) CISPR 32
Environment	EN IEC 63000
Shock	IEC 60068-2-27
Freefall	IEC 60068-2-32
Vibration	IEC 60068-2-6
Railway applications	EN 50121-1 EN 50121-3-2 IEC 62236-1 IEC 62236-3-2 IEC 60571 clause 5.4, 5.5



## 19.7 Technical data

### Electrical

Power transfer	
Power supply input PWR1-2	
Input voltage	24 – 48 VDC
Input voltage tolerance	16.8 – 62.4 VDC
Power consumption (48 V)	
Active mode, no PoE	12 W
Active mode, with PoE	< 140 W
Power over Ethernet	
Standard	IEEE 802.3 af/at
Output power, all ports together	< 120 W
Output power, per port (1-8)	< 30 W

Supervision	
Redundant power failure	P-Fail relay / Alarm LED
Port link down	P-Fail relay / Alarm LED
Fiber link down	P-Fail relay / Alarm LED
Device status reporting	SNMP, SMTP

Network interface	
Ethernet	
Speed	100BASE-TX 1000BASE-T
Ports 1-8	RJ45
Ports 9-10	RJ45/SFP combo
Console	
Standard	RS232
Port	RJ45

Reliability	
MTBF	800,000 h

### Environmental

Climatic conditions	
Temperature	
Operating	-10 – 60 °C (-14 – 140 °F)
Storage and transport	-40 – 85 °C (-40 – 185 °F)
Humidity (non-condensing)	5 – 95%

**Functional**

<b>Switching</b>	
MAC-address table size	8k
VLAN Group Arrange	IEEE 802.1Q 256 (VLAN ID1-4094) Port based, Q-in-Q, GVRP
Multicast	IGMP snooping v1/v2/v3, MLD snooping, IGMP immediate leave
Energy Efficient Ethernet	IEEE 802.3az EEE
Redundancy	IEEE 802.1D-STP IEEE 802.1s-MSTP IEEE 802.1w-RSTP

<b>QoS</b>	
Priority queue scheduling	SP, WRR
Class of service (CoS)	IEEE 802.1p, DiffServ (DSCP)
Rate limiting	Ingress, Egress
Link aggregation	IEEE 802.3ad Static, Dynamic (LACP)

<b>Security</b>	
Port security	Static, Dynamic
Authentication	IEEE 802.1X, port based
Storm control	Broadcast, Unknown multicast, Unknown unicast

<b>Management</b>	
DHCP	Client, Server
Access	SNMP v1/v2c/v3, RMON, Telnet, SSH, HTTP(S), CLI
Software upgrade	TFTP, HTTP (dual image)
NTP	SNTP client

**Mechanical**

<b>Enclosure</b>	
Dimensions (HxWxD)	152 x 74 x 105 mm (6.0 x 2.9 x 4.1 in)
Ingress protection	IP30
Mounting	TS35 DIN Rail (EN 60715), Wall-mounting
Case	Aluminum
Weight	1.3 kg (2.7 lb)

## 20 Fiber transceiver (SFPLX, SFPSX)



### 20.1 Introduction

The PRA-SFPSX and PRA-SFPLX are compact SFP fiber transceivers. The PRA-SFPSX is for use with multi-mode fibers, covering distances up to 550 m. The PRA-SFPLX is for use with single mode fibers, covering distances up to 10 km. These are OEM transceivers, made for Bosch by Advantech for use in Bosch Public Address and Voice Alarm systems. An SFP transceiver locks into the SFP socket of the PRAESENSA multifunction power supply and Ethernet switch. It is compliant with IEEE 802.3z Gigabit Ethernet standards for maximum performance, reliability and flexibility. Both transceivers are certified for EN 54-16 in combination with PRAESENSA systems.

### 20.2 Functions

- Features a duplex LC connector; one connection for transmit and the other for receive.
- Fits and locks into the SFP socket of the PRA-MPSx and PRA-ES8P2S.
- SFP is the popular industry format jointly developed and supported by many network component vendors, providing a connection to different types of optical fiber.
- The PRA-SFPSX supports multi-mode fiber for distances up to 550 m.
- The PRA-SFPLX supports single-mode fiber for distances up to 10 km.
- Wide temperature range for maximum reliability.
- Certified for EN 54-16 in combination with PRAESENSA systems.

### 20.3 Functional diagram

Functional and connection diagram

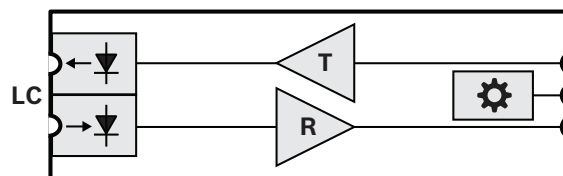

Internal device functions

- LC** Dual lockable transmitter and receiver connector
- T** Transmitter
- R** Receiver
-  Controller

## 20.4 Installation

The fiber transceiver fits and locks into the SFP socket of the PRA-MPSx and PRA-ES8P2S. The transceiver receives power from the host device.

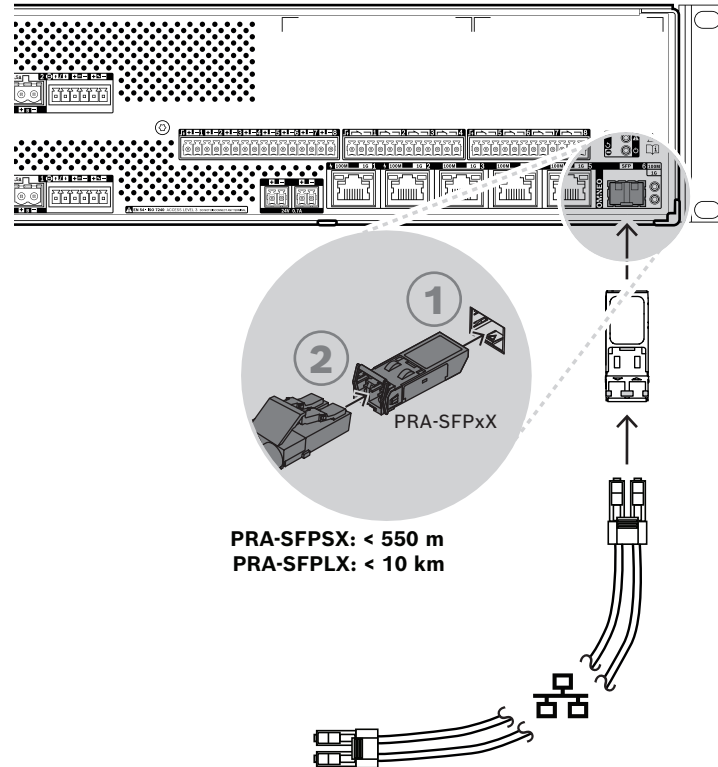

### Caution!

Risk of eye injury. When inspecting a connector, ensure that light sources are off. The light source in fiber optic cables may cause eye injury. SX and LX fiber connections use invisible IR light.

### 20.4.1 Parts included

The box contains the following parts:

Quantity	Component
1	SFP fiber transceiver

No tools or Ethernet cables are provided with the device.

### 20.4.2 Application

Fiber transceivers are especially beneficial in environments where high levels of electromagnetic interference (EMI) is a common phenomenon, like industrial plants. This interference can cause data corruption over copper-based Ethernet links. However, data transmitted over fiber optic cable is completely immune to this type of noise, ensuring optimal data transmission across the plant floor.

For short distance transmissions multi-mode fibers can be used using light with a wavelength of 850 nm, while single-mode fibers typically support distances up to 10 km, using light with a wavelength of 1310 nm. Some third party dedicated SFP fiber transceivers

can even cover distances up to 40 km, using light with a wavelength of 1550 nm for lowest attenuation of light. However, for EN 54-16 compliant PRAESENSA systems only the PRA-SFPLX and PRA-SFPSX are certified for use.

Make sure to use the correct combination of fiber and connector for both sides of the cable, matching the fiber transceivers. A connection between a multi-mode fiber transceiver on one end and a single-mode fiber transceiver on the other end will not work, because the wavelength of the light that is produced by the transmitter does not match the wavelength of the light the receiver is sensitive to.

Fiber optic cables are exceptionally vulnerable. Dust, dirt or tampering might cause physical damage. To avoid physical damage, avoid extreme bends in fiber optic cables when storing them and put dust-caps on the cable ends after disconnection. Also, see subsection *Cable type recommendations*, page 30 for safety precautions when working with fiber optic cables.

#### Notice!



The SFP transceiver is not standardized by any official standards body, but rather is specified by a multi-source agreement (MSA) among competing manufacturers. Some networking equipment manufacturers engage in vendor lock-in practices whereby they deliberately break compatibility with generic SFPs by adding a check in the device's firmware that will enable only the vendor's own modules. As a result, this means that the PRA-SFPLX and PRA-SFPSX may not work in some brands of Ethernet switches.

### 20.4.3

#### Transceiver

To install an SFP transceiver, follow the procedure below:

1. An SFP transceiver can be damaged by static electricity. Be sure to observe all standard electrostatic discharge (ESD) precautions, such as wearing an antistatic wrist strap, to avoid damaging the transceiver.
2. Remove the transceiver from its packaging.
3. Position the SFP transceiver with the label facing up. The transceiver can be hot-swapped; there is no need to power-off the host device to install a transceiver.
4. With the handle on the transceiver oriented towards the host device, slide the transceiver into the SFP socket and push until it clicks into place.
5. Verify that the handle on the transceiver is in the position that secures the transceiver and prevents it from being dislodged from the socket.

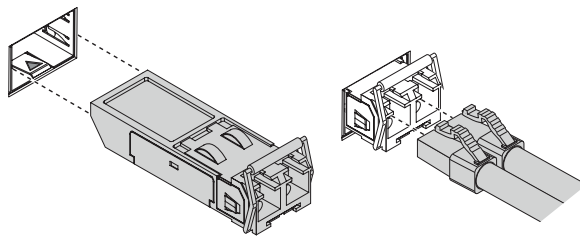

### 20.4.4

#### Fiber cable

To insert a fiber cable with LC connector, follow the procedure below:

1. Verify that the type of cable is appropriate for the SFP transceiver that is installed.
2. The SFP transceiver has two connectors. Each connector connects to a separate fiber strand. One is for receiving data and the other is for transmitting data. When connecting a fiber optic cable to the SFP module, be sure that the receive fiber connector is connected to the transmitter connector on the remote end-node device, and the transmit fiber connector is connected to the receiver connector on the remote node.

3. Remove the dust plugs from the LC fiber cable and save the dust plugs for future use. Then inspect and clean the cable end-face.
4. Remove the dust plugs from the SFP transceiver optical bores. Immediately attach the LC fiber cable to the SFP transceiver.

## 20.5

### Approvals

Emergency standard certifications	
Europe	EN 54-16 (0560-CPR-182190000)
International	ISO 7240-16
Maritime applications	DNV GL Type Approval
Emergency standard compliance	
Europe	EN 50849
UK	BS 5839-8
Regulatory areas	
Safety	Laser Class I IEC 60825-1
Immunity	EN 55035
Emissions	EN 55032 EN 61000-3-2 EN 61000-3-3
Environment	EN/IEC 63000

## 20.6

### Technical data SFPSX

#### Electrical

Interface	
Supply voltage	3.3 V
Power consumption	0.5 W
Speed	IEEE 802.3z 1000BASE-SX
Transmitter power	-4 – -9.5 dBm
Receiver sensitivity	< -18 dBm
Connection	Hot swappable, Locking

#### Optical

Interface	
Connector type	Dual LC
Wave length	850 nm
Fiber length 50 µm core 62.5 µm core	< 550 m (1.804 ft) < 220 m (722 ft)

<b>Interface</b>	
Optical fiber	Multi-mode
Core size	50 $\mu\text{m}$ / 62.5 $\mu\text{m}$

**Environmental**

<b>Climatic conditions</b>	
Temperature	
Operating	-20 – 85 °C (-4 – 185 °F)
Storage and transport	-40 – 85 °C (-40 – 185 °F)
Humidity (non condensing)	5 – 95%

**Mechanical**

<b>Enclosure</b>	
Dimensions (HxWxD)	13.4 x 8.5 x 56.5 mm (0.53 x 0.33 x 2.2 in)
Weight	75 g (0.17 lbs)

**20.7****Technical data SFPLX****Electrical**

<b>Interface</b>	
Supply voltage	3.3 V
Power consumption	0.7 W
Speed	IEEE 802.3z 1000BASE-LX
Transmitter power	-3 – -9.5 dBm
Receiver sensitivity	< -20 dBm
Connection	Hot swappable, Locking

**Optical**

<b>Interface</b>	
Connector type	Dual LC
Wave length	1310 nm
Fiber length	< 10 km (32,821 ft)
Optical fiber	Single-mode
Core size	ITU-T G.652 SMF



**Environmental**

<b>Climatic conditions</b>	
Temperature	
Operating	-40 – 85 °C (-40 – 185 °F)
Storage and transport	-40 – 85 °C (-40 – 185 °F)
Humidity (non condensing)	5 – 95%

**Mechanical**

<b>Enclosure</b>	
Dimensions (HxWxD)	13.4 x 8.5 x 56.5 mm (0.53 x 0.33 x 2.2 in)
Weight	75 g (0.17 lbs)

## 21 Public Address server (APAS)



### 21.1 Introduction

The PRA-APAS is an industrial PC with pre-installed software, acting as a server for PRAESENSA. It provides advanced business related public address functions without compromises and does therefore not support emergency functionalities.

The PRA-APAS supports connections to two separate local area networks, the PRAESENSA secure network and the public network with access to the Internet, with a firewall in between. On the public network it connects to the Internet and to one or more licensed operator devices, such as a wireless tablet or a regular PC. On the secure PRAESENSA network it interfaces with the system controller for control and transfer of multiple simultaneous audio channels.

The operator devices use their own web browser to control background music, streaming from PRA-APAS' own internal memory or from external music portals and Internet radio stations. It offers announcement creation and control facilities to the operator, including message scheduling, live call recording with pre-monitoring and playback, and even multi-lingual text-to-speech calls, using on-line conversion service. The Configuration manual contains a link to the service provider's website for information on the languages available.

### 21.2 Functions

#### Public address server

- Industrial PC with pre-installed and licensed software, acting as server to one or more operator control devices, and as interface between these devices and one PRAESENSA system.
- For security reasons the server has two ports to connect to two different local area networks. One port is connected to the secure PRAESENSA network, the other port to the corporate network with access to operator devices and (Firewall protected) access to the Internet.
- License management of operator devices. Each operator device needs a PRA-APAL license for access to the advanced public address server.
- Integrated web server to keep operator devices platform independent. Each operator device uses its own web browser as operator interface.
- Storage of messages and music in internal memory, multiple audio formats supported.

#### Operator functions

- Easy zone selection with picture representation of zones.
- Control of background music sources and volume levels in selected zones. Music can be streamed from internal memory, but also from music portals on Internet.

- Live call recording of announcements with pre-monitoring and playback to selected zones.
- Live and scheduled playback of stored messages.
- Playback of text based announcements with automatic (multi-lingual) on-line text-to-speech conversion.

**Connection to PRAESENSA**





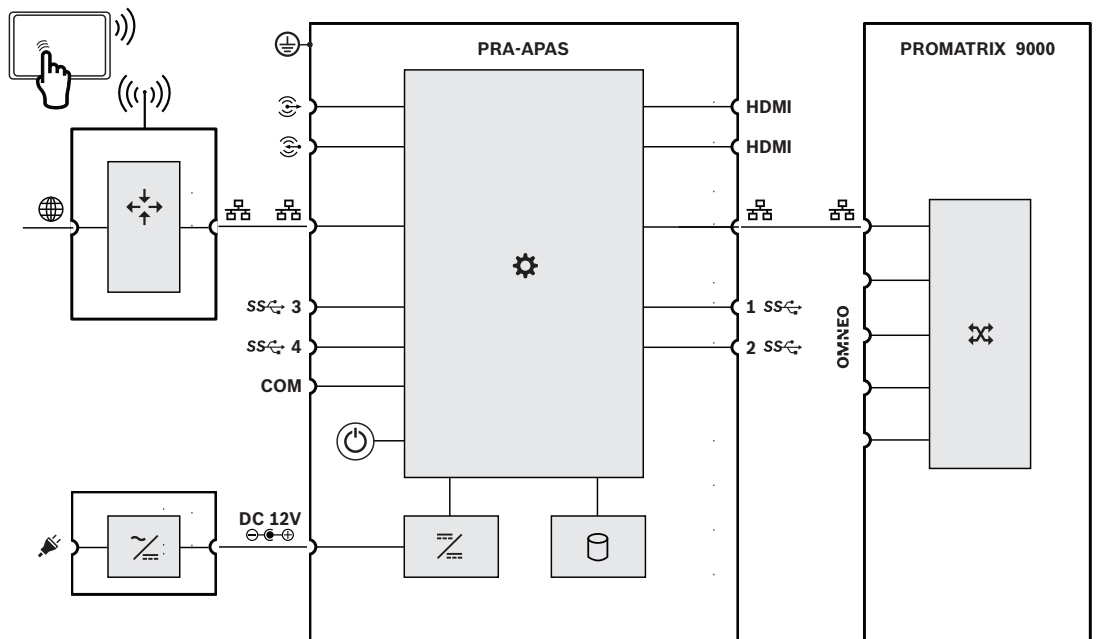

- The server connects to the PRAESENSA system controller, using the PRAESENSA Open Interface for control of business related functions. Higher priority, emergency related functions are always handled by the system controller and will overrule PRA-APAS activities.
- The server can stream up to 10 high quality audio channels to the system controller, using the AES67 protocol. The system controller converts the static AES67 audio streams into dynamic OMNEO streams.

## 21.3 Functional diagram

**Connection and functional diagram**



**Internal device functions**

-  Router
-  Mains to DC converter
-  Controller
-  Power on
-  DC to DC converter
-  Processor and storage
-  OMNEO network switch

## 21.4 Indicators and connections



### Front panel control and indicators

	Processor and storage	Red		Power on	Green
	Active/Link status Speed status	Green Yellow			

### Front panel connections

	Line input			Line output	
	Network port			Super speed USB 3 and 4	
<b>COM</b>	Serial port				

### Rear panel indicators



	Active/Link status Speed status	Green Yellow			
--	------------------------------------	-----------------	--	--	--

### Rear panel connections

	12 VDC input			Chassis ground	
<b>HDMI</b>	HDMI display interface			Super speed USB 1 and 2	
	Network port		<b>HDMI</b>	HDMI display interface	

## 21.5 Installation



### Notice!

For detailed installation instructions, please refer to the manufacturer’s manual.

Manufacturer: Advantech

Model: ARK-1124H

### 21.5.1

#### Parts included

The box contains the following parts:

Quantity	Component
1	Advanced public address server
1	Power adapter
1	Mounting bracket (Advantech AMK-R001E)
1	Utility CD
1	User manual (in Simplified Chinese)

No tools or cables are provided with the device.

### 21.5.2

#### Power adapter

The PRA-APAS is delivered with an external 12 VDC power adapter. Connect the adapter to the PRA-APAS through the DC input on the rear side.

### 21.5.3

#### Mounting bracket

The comes PRA-APAS with a bracket to mount the device on a standard DIN-rail or on a flat surface.

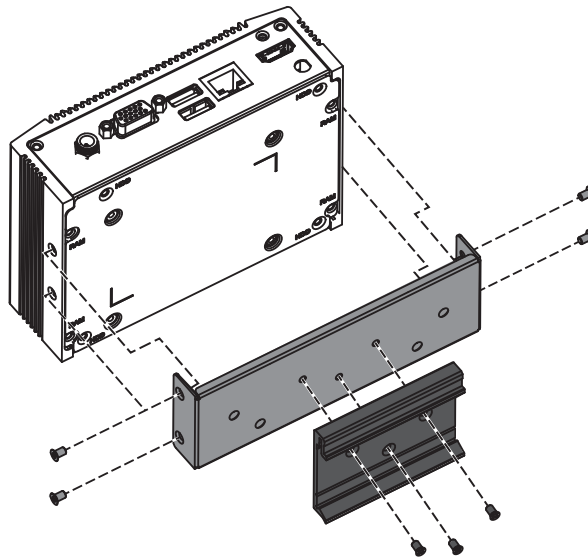

## 21.5.4 Network connections

When the PRA-APAS connects to the PRAESENSA system in a closed network, use the Ethernet connection in the rear side to connect to the PRAESENSA network. When the PRA-APAS also uses external services through the Internet, the PRA-APAS connects through the Ethernet connection in the rear side to the PRAESENSA network, and through the Ethernet connection in the front side to an open network with Internet access.



### Notice!

Only one PRA-APAS must be connected to the PRAESENSA network.

## 21.5.5 Configuration

The configuration of the PRA-APAS device is described in a dedicated configuration manual for the PRA-APAS Advanced public address server. Download the latest version of the manual from [www.boschsecurity.com](http://www.boschsecurity.com).

## 21.6 Approvals

Regulatory areas	
Safety	EN/IEC 62368-1 EN 62311
Immunity	EN 61000-6-1 EN/IEC 61000-3-2 EN/IEC 61000-3-3 EN/IEC 61000-4-2 EN/IEC 61000-4-3 EN/IEC 61000-4-4 EN/IEC 61000-4-5 EN/IEC 61000-4-6 EN/IEC 61000-4-8 EN/IEC 61000-4-11 EN 55035
Emissions	EN 55011 EN 55032 / CISPR 32 EN 61000-6-3 EN 61000-6-4 ICES 003 FCC 47 part 15B class A
Environment	EN/IEC 63000
Radio equipment	EN 300 328 EN 301 893

## 21.7 Technical data

### Electrical

Server PC	
Model	ARK-1124H-S6A1E (OEM Advantech)

<b>Server PC</b>	
Processor chipset	Intel Atom™ E3940 Quad Core SoC
Processor speed	1.6 GHz
L2 Cache	2 MB
BIOS	AMI EFI 64 bit
Memory	DDR3L 1866 MHz, 8 GB
Solid State Drive (SSD)	256 GB
Operating system	Linux
Graphics chipset	Intel® HD Graphics 500
Video interface	HDMI 1.4b, dual display
Ethernet chipset	Intel i210 GbE
LAN1/2	100BASE TX, 1000BASE T
Audio chipset	Realtek ALC888S,
Audio in/out (inactive)	2 x analog mini-jack
Serial interface	RS-232/422/485
USB Interface	4 x USB 3.0
Protection	Watchdog timer
Backup battery	CR2032 Lithium cell
Power consumption, typical	6 W
Power consumption, maximum	16 W
External power adapter	12 VDC, 5 A
Power connector	Lockable DC jack
Cooling	Fanless convection

<b>Power adapter</b>	
Model	ADP-60KD B (Delta)
Input voltage range	100 – 240 VAC
Input voltage tolerance	90 – 264 VAC
Frequency range	47 – 63 Hz
Socket type input	C14
Output voltage	12 VDC
Maximum output current	5 A
Connector type output	Lockable DC jack
Efficiency level (DOE)	VI

<b>Power adapter</b>	
Protection	Over voltage Over current Over temperature

**Environmental**

<b>Climatic conditions server PC</b>	
Operating temperature	-20 – 60 °C (-4 – 140 °F) with 0.7 m/s air flow
Storage and transport temperature	-40 – 85 °C (-40 – 185 °F)
Humidity (non-condensing)	5 – 95%
Vibration (operating, no HDD)	3 Grms, IEC 60068-2-64, random, 5 to 500 Hz, 1 hr/axis
Shock (operating, no HDD)	30 G, IEC 60068-2-27, half sine, 11 ms duration

<b>Climatic conditions power adapter</b>	
Operating temperature	0 °C – 40 °C (32 °F – 104 °F)
Storage and transport temperature	-30 °C – 60 °C (-22 °F – 140 °F)
Altitude	-500 – 5000 m (-1640 – 16404 ft)

**Mechanical**

<b>Enclosure server PC</b>	
Dimensions (HxWxD)	46.4 x 133 x 94.2 mm (1.83 x 5.24 x 3.71 in)
Case Material Color	Aluminum Black
Weight	0.7 kg (1.55 lb)

<b>Enclosure power adapter</b>	
Dimensions (W x H x D)	110 x 62 x 31.5 mm (4.33 x 2.44 x 1.24 in)



## 22

# Power supply module (PSM24, PSM48)

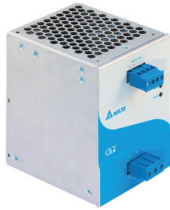

### 22.1

## Introduction

The PRA-PSM24 and PRA-PSM48 are compact DIN-rail mounted power supplies. The PRA-PSM24 delivers 24 V at up to 10 A continuously, while the PRA-PSM48 delivers 48 V at up to 5 A continuously. These power supplies are OEM power supplies, made for Bosch by Delta Power Supply, as a cost effective alternative to the PRAESENSA multifunction power supply PRA-MPS3 in case the additional functions and characteristics of the multifunction power supply are not needed. Also, the PRA-PSM24 and PRA-PSM48 are not certified for EN 54-4 and similar standards.

The PRA-PSM24 can be used to power a PRAESENSA system controller or other devices and utilities that need 24 V.

Because of its ability to deliver high peak currents, the PRA-PSM48 can supply sufficient power to a single fully loaded PRAESENSA 600 W power amplifier. The PRA-PSM48 can also power a PRA-ES8P2S Ethernet switch with all its PoE outputs loaded.

### 22.2

## Functions

### Mains power supply

- Universal mains input with power factor correction to maximize the amount of power that can be taken from a single phase power distribution network.
- The mains is supplied via a 3-pole screw plug that requires the module to be installed by professional installers and mounted in a safe place, without user access.

### PRA-PSM24

- Compact DIN-rail mounted power supply, delivering 24 V at up to 10 A continuously, for powering various utilities and devices in Public Address systems.
- Adjustable output voltage, 24 to 28 V.
- For fail safe redundancy it is possible to use two 24 V power supplies for one PRAESENSA system controller, one connected to its 24 V input A and the other to input B. In that case, the power supply with the highest voltage will supply the power, the other one is available as backup.

### PRA-PSM48

- Compact DIN-rail mounted power supply, delivering 48 V at up to 5 A continuously, for powering one fully loaded PRAESENSA 600 W amplifier. Because the long term effective power consumption of the amplifier is much lower than the short term burst power consumption, related to the crest factor of speech and music, this power supply is sufficiently powerful.
- Adjustable output voltage, 48 to 56 V, of which the range 48 to 50 V can be used because the PRAESENSA power amplifiers are tolerant up to 50 V.
- For fail safe redundancy it is possible to use two 48 V power supplies for one amplifier, one connected to its 48 V input A and the other to input B. In that case the amplifier load will be shared by both power supplies, even if the supply voltages are adjusted to be slightly different.

**Protections**

- Overvoltage protection with automatic recovery.
- Overload protection with automatic recovery.
- Over-temperature protection with automatic recovery.

**22.3**

**Functional diagram**

**Functional and connection diagram**

PRA-PSM24

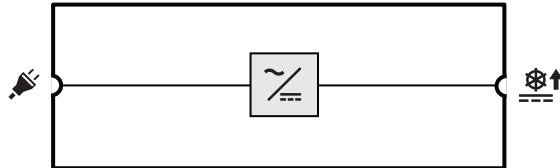

PRA-PSM48

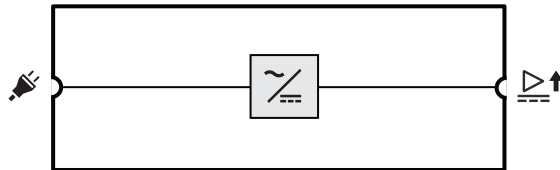

**Internal device functions**

Mains to DC converter

**22.4**

**Indicators and connections**

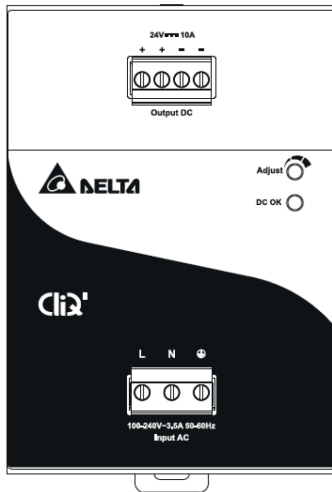

**Front panel indicator and control**

DC OK	Output voltage present	Green	Adjust	Output voltage adjustment	Rotary control
-------	------------------------	-------	--------	---------------------------	----------------

**Front panel connections**

	24 VDC or 48 VDC output			Mains input	
--	-------------------------	--	--	-------------	--

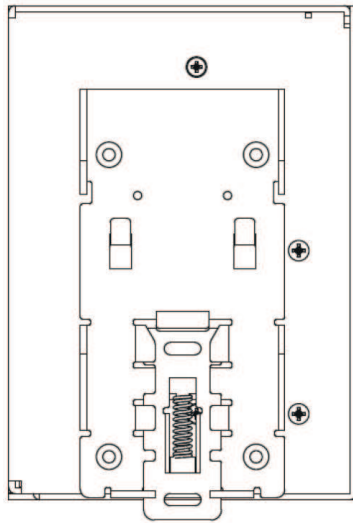
**Rear view****22.5****Installation****Caution!**

These power supplies must be installed and used in a controlled environment. The PRA-PSM24 and PRA-PSM48 are built-in units and must be installed in a cabinet or room (condensation-free and indoor) that is relatively free of conductive contaminants. The mains power connection of these devices is not touch-protected.

## 22.5.1

### Parts included

The box contains the following parts:

#### PRA-PSM24

Quantity	Component
1	Power supply module 24 V
1	Set of screw connectors
1	Manufacturer's datasheet

#### PRA-PSM48

Quantity	Component
1	Power supply module 48 V
1	Set of screw connectors
1	Manufacturer's datasheet

No tools or cables are provided with the devices.

## 22.5.2

### Mounting

The power supply unit can be mounted on a 35 mm DIN-rail in accordance with EN 60715. The device must be installed vertically with the mains power input terminal block down.

#### Safety precautions:

1. Switch main power off before connecting or disconnecting the device.
2. To guarantee sufficient convection cooling and prevent that the unit goes into thermal protection, it is important to keep a distance of at least 100 mm above the device, 200 mm below the device, as well as a lateral distance of 20 mm to other units.
3. Note that the enclosure of the device can become very hot depending on the ambient temperature and load of the power supply. Risk of burns!
4. Only plug in and unplug connectors when power is turned off.
5. Do not introduce any objects into the unit.
6. Dangerous voltage present for at least 5 minutes after disconnecting all sources of power.

#### To snap the device on a DIN-rail, follow the procedure below:

1. Tilt the device slightly upwards and put it onto the DIN-rail.
2. Push the device downwards until stopped.
3. Press against the bottom of the front side to lock the device on the rail.
4. Shake the unit slightly to ensure that it is secured.

#### For dismantling the device:

1. Pull or slide down the latch at the rear side bottom with a screwdriver.
2. Tilt the device upwards.
3. Release the latch, and pull the device from the rail.

### 22.5.3 Mains connection

The terminal block connector allows for easy and fast wiring.

For connecting the mains power to the power supply, follow the procedure below:

1. Use standard flexible (stranded wire) or solid cables with a cross section of 0.75 to 2.5 mm<sup>2</sup> (AWG 18 to 14), designed to sustain an operating temperature of 75°C (167°F).
2. For secure and reliable connections, the stripping length should be 7 mm.
3. For safety, ensure that all wires are fully inserted into the connecting terminals. In accordance to EN 60950 / UL 60950, flexible cables require ferrules.
4. Fix the L (Live), N (Neutral) and PE (Protective Earth) connection wires to the input terminal connector to establish the 100 to 240 VAC connection, using a torque of 0.5 Nm.
5. Plug the connector into the power supply.

The unit is protected with an internal fuse (not replaceable) at the L input and the power supply has been tested and approved on 20 A (UL) and 16 A (IEC) branch circuits without an additional protection device. An external protection device is only required if the supplying branch has a current capability greater than this. Thus, if an external protective device is necessary or utilized, a circuit breaker must be used with a minimum value of 4 A (B-characteristic) or 2 A (C-characteristic).



#### Caution!

The internal fuse must not be replaced by the user. In case of an internal defect, return the unit for inspection.

### 22.5.4 Output connection

Use the positive (+) and negative (-) screw connections to establish the 24 V (PRA-PSM24) or 48 V (PRA-PSM48) connection. The output voltage can be adjusted upwards to 28 V or 56 V with the front side potentiometer, but for use with PRAESENSA keep the power supply at 24 V or 48 V. The green LED DC OK displays the correct functioning of the output. The device has a short circuit and overload protection and an overvoltage protection.

For connecting the output to a PRAESENSA device, proceed as follows:

1. Use a PRA-PSM24 to power a PRA-SCx system controller or auxiliary device designed for 24 V operation.
2. Use a PRA-PSM48 to power a PRA-AD60x multi-channel amplifier or PRA-ES8P2S Ethernet switch, designed for 48 V operation.
3. Use standard flexible (stranded wire) or solid cables with a cross section of 1.5 to 2.5 mm<sup>2</sup> (AWG 16 to 14), designed to sustain an operating temperature of 75°C (167°F).
4. For secure and reliable connections, the stripping length should be 7 mm.
5. For safety, ensure that all wires are fully inserted into the connecting terminals. In accordance to EN 60950 / UL 60950, flexible cables require ferrules.
6. Use a torque of 0.5 Nm on the screws to secure the wire connections.
7. For cable redundancy use two cables in parallel (2x2 wires) between the dual output connections of the power supply and the A and B inputs of the loads to be connected.

In the event of a short circuit or overload, the output voltage and current collapses when the overload current exceeds 150% of the maximum output current. The output voltage is then reduced and the power supply enters the hick-up mode until the short circuit or overload has been removed.

## 22.5.5

### Thermal behavior

In the case the ambient temperature exceeds +50°C (for vertical mounting), the load power is to be reduced by 2.5% per degree Celsius increase in temperature. If the load is not reduced, the device will run into thermal protection by switching off; the device will go in hick-up mode and will recover when the ambient temperature is lowered or the load is reduced as far as necessary to keep the device within normal working conditions.

## 22.6

### Approvals

Emergency standard certifications	
Maritime applications	DNV-GL Type Approval (PRA-PSM48 only)
Emergency standard compliance (PRA-PSM48 only)	
Europe	EN 50849
UK	BS 5839-8
Regulatory areas	
Safety	EN 62368-1 EN 62477-1
Immunity	EN 61000-6-1 EN 61000-6-2
Emissions	EN 55032 EN 55011 CISPR 32 CISPR 11 FCC-47 part 15B class B EN/IEC 61000-3-2, Class A EN 61204-3
Environment	EN/IEC 63000
Railway applications	EN 50121-4 (PRA-PSM48 only)

## 22.7

### Technical data

#### Electrical

##### PRA-PSM24

Power transfer	
Mains power supply input	
Input voltage range	100 – 240 VAC
Input voltage tolerance	85 – 264 VAC
Frequency range	50 – 60 Hz

<b>Power transfer</b>	
Inrush current	< 35 A (115 V, 230 V)
Power factor (PF)	0.9 – 1.0
Leakage current to safety ground	< 1 mA (240 V)
24 VDC output	
Nominal DC output voltage	24 V
Output voltage range	24 – 28 V
Maximum continuous current	10 A
Derating	-0.25 A/°C above 50°C
Maximum peak current	15 A
Power consumption	
Active mode, rated power	265 W
Heat loss	
Active mode, rated power	90 kJ/h (85 BTU/h)

**PRA-PSM48**

<b>Power transfer</b>	
Mains power supply input	
Input voltage range	100 – 240 VAC
Input voltage tolerance	85 – 264 VAC
Frequency range	50 – 60 Hz
Inrush current	< 35 A (115 V, 230 V)
Power factor (PF)	0.9 – 1.0
Leakage current to safety ground	< 1 mA (240 V)
48 VDC output	
Nominal DC output voltage	48 V
Output voltage range	48 – 56 V
Maximum continuous current	5 A
Derating	-0.125 A/°C above 50°C
Maximum peak current	7.5 A
Power consumption	
Active mode, rated power	265 W
Heat loss	
Active mode, rated power	90 kJ/h (85 BTU/h)

**PRA-PSM24 and PRA-PSM48**

<b>Protection</b>	
Overvoltage	Automatic recovery
Overload	Automatic recovery
Over-temperature	Automatic recovery

<b>Reliability</b>	
MTBF	500,000 h

**Environmental**

<b>Climatic conditions</b>	
Temperature	
Operating	-25 – 80 °C (-13 – 176 °F )
Storage and transport	-40 – 85 °C (-40 – 185 °F )
Humidity (non-condensing)	5 – 95%
Air pressure	750 – 1070 hPa
Altitude (operating)	0 – 2500 m (0 – 8200 ft)
Vibration (operating)	
Amplitude	< 0.35 mm
Acceleration	< 3 G
Bump (transport)	< 10 G (IEC 60068-2-27)
<b>Airflow</b>	
Cooling	Convection

**Mechanical**

<b>Enclosure</b>	
Dimensions (HxWxD)	121 x 85 x 124 mm (4.76 x 3.35 x 4.86 in)
Ingress protection	IP20
Mounting rail	TS35 DIN Rail (EN 60715)
Case	Aluminum

**PRA-PSM24**

Weight	1.10 kg (2.43 lb)
--------	-------------------

**PRA-PSM48**

Weight	0.96 kg (2.12 lb)
--------	-------------------



## 23 Application notes

Sometimes applications using PRAESENSA have very specific requirements or face special installation challenges. This chapter shows possible solutions to some of them.

### 23.1 Connecting 100 Mbps-devices

Some Dante devices only have a 100BASE-TX connection, but also many control devices, like a Fire Alarm system, only support a 100BASE-TX connection. This is the case for the Encrypted Smart Safety Link that is used by the AVENAR panels. Devices that have a low speed 100BASE-TX network interface are only allowed at the endpoints of a PRAESENSA network and may not be looped through. However, even if such a device is connected as an endpoint, take into consideration the maximum number of audio channels on the network. PRAESENSA uses multicast traffic which is actually broadcast within the subnet to all switch ports. Because every OMNEO channel requires 2.44 Mbps, keep the number of (multicast) OMNEO audio channels below 20 to not exceed the available network bandwidth. When **more than 20** simultaneous multicast audio channels are needed on the network, it must be avoided that all this traffic is forwarded to the 100 Mbps link. This is possible by using a switch with IGMP-snooping. The low speed 100 Mbps-devices must then be connected to a port on the switch that runs IGMP-snooping on that port. OMNEO devices may be connected to other ports of that switch, but for these ports IGMP-snooping must be disabled and these ports should **not filter** multicast traffic.

**Notice!**

Do not connect OMNEO or Dante behind a port that uses IGMP-snooping. Refer to *Network switches*, page 37.

**Notice!**

Dante devices that are based on the Audinate's Ultimo chip (e.g. Dante AVIO audio network adapters, Atterotech unDIO2X2+) are limited to a 100BASE-TX connection. When such a device is used, the maximum number of simultaneous OMNEO audio channels in PRAESENSA is 20.

**Refer to**

- *Network switches*, page 37

### 23.2 Long range interconnections

Copper CAT-wiring for Ethernet is limited to a distance of 100 m between nodes. Longer distances can be covered by using Gigabit fiber interconnections with SFP transceivers. Some PRAESENSA devices have one or more SFP sockets for this purpose. But call stations need Power over Ethernet (PoE), which cannot be transported on fiber connections. For distances above 100 m there are several possibilities:

- It is possible to use special Ethernet cables that deliver 1 Gbps and PoE+ over 200 m and pull and terminate like a CAT6 cable.  
See Gamechanger cables (<http://www.paigedatacom.com/>).
- Use one or more Gigabit PoE Ethernet extenders/repeaters. Typically, up to four or five can be daisy chained, each one adding a new stretch of 100 m, up to around 600 m in total. The repeaters themselves are powered from the incoming PoE source and also forward PoE to the connected call station. Multiple repeaters may need a PoE+ power source in order to still have adequate PoE power left for the call station. These extenders do not need mains power.

- Some extenders provide a PoE point-to-point solution of up to 800 m with no mid-cable equipment and no far-end power source, but only for 100BASE-T Ethernet. As an exception to the rule that 1000BASE-T is needed, this may be used for edge devices only, such as a single call station without loop-through connection to other PRAESENSA devices. The maximum number of (multicast) OMNEO audio channels must be kept below 20 in order not to exceed the available network bandwidth. See section *Connecting 100 Mbps-devices*, page 281 for more information. See Longspan (<http://www.veracityglobal.com/>).

There are also Ethernet bridges on the market that can cover even longer distances and use CAT, coax or telephone wiring. Although they may have Gigabit Ethernet connections on the end-devices, they do not use 1000BASE-T Ethernet on the long distance interconnections but other (slower) communication links like VDSL. Do **not** use these kind of range extenders for PRAESENSA because they have too much packet arrival jitter and do not support PTP for synchronization of audio devices! For the same reason Wi-Fi or other wireless interfaces cannot be used.

### 23.3 Compatibility with other network data

Devices that use OMNEO/Dante/AES67 should never be used with active CobraNet devices on the same network to avoid disturbance of clocking data. If this is not possible, then use an additional VLAN to keep CobraNet devices separated.

Make sure jumbo frames are not present on the network, because jumbo frames will increase the packet jitter to an unacceptable level. One packet in a jumbo frame can contain up to 9000 bytes which blocks the network too long for other traffic.

### 23.4 Static IP-binding

Many applications and devices can connect through hostnames, so they do not need a fixed or static IP-address to establish a connection. Using hostnames is easier to configure and maintain because it avoids IP-address conflicts and makes hardware replacements easier. However, some applications do not (yet) support hostnames. They need an IP-address to setup a connection.

By default, the PRAESENSA IP-addresses are assigned through DHCP. However, since software release V1.61, PRAESENSA supports static IP-addresses that can be assigned through a separate application, the PRAESENSA Network Configurator. This application can assign fixed IP-addresses to all networked PRAESENSA devices.

#### Notice!

The Bosch modular fire panels AVENAR panel 2000 and AVENAR panel 8000, with firmware version 4.x or higher, can control the PRAESENSA system through the Open Interface of the PRAESENSA system controller. This connection is called the Encrypted Smart Safety Link. It creates an interface between the fire detection system and the voice alarm system. These AVENAR panels only support a static IP-address to establish a connection. In this case, configure the PRAESENSA system to use static IP-addresses with the PRAESENSA Network Configurator. PRAESENSA systems with software versions older than V1.61 cannot use this tool. You need to upgrade them to a newer software version. If that is not possible, you can still use the function static IP-binding. The AVENAR panels support PRAESENSA controller redundancy through automatic synchronization. This requires AVENAR firmware 4.0.2 or higher.



When a software version older than V1.61 is used, it is not possible to configure a static IP-address in the system controller. It is not possible to use the Link Local address of the system controller or an address assigned by a DHCP-server, because this address can change after a power cycle or reset. It still does not work even when the Ethernet switch with the DHCP-server can create a pool of only one IP-address that would always be given to the device connected to a certain port of the switch, because the PRAESENSA system controller has two MAC-addresses.

The solution is to use a switch, such as the PRA-ES8P2S, that has a DHCP-server that supports static IP-binding to a MAC-address.

The PRAESENSA system controller has two MAC-addresses:

- The device MAC-address. This is the MAC-address, where the device hostname is derived from, using the format 'PRASCL-xxxxxx', with xxxxxx being the last six hexadecimal digits of the device MAC-address.
- The control C MAC-address. This is the physical address that is linked to the control hostname, although the control hostname itself is just the device hostname with an extension '-ctrl.local'. This 'PRASCL-xxxxxx-ctrl.local' is the URL of the webserver in the system controller. The same control hostname is also used for the Open Interface.

Both the MAC and the C MAC addresses are shown on the product label of the system controller. The C MAC-address is the physical address that is needed for IP-binding.

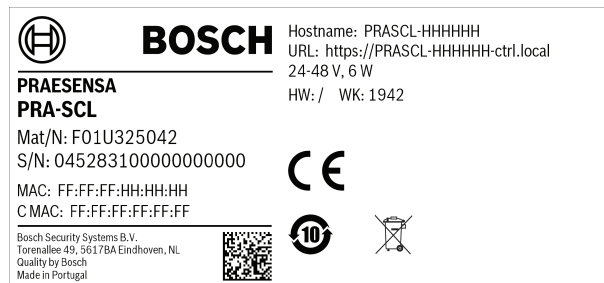

If the product label is inaccessible, then the following steps 1-3 will make the C MAC-address known. If the C MAC-address is already known these steps can be skipped.

1. The device hostname can be learned from the system configuration, in the System composition web page, or from the Firmware upload tool. The control hostname is the device hostname extended with '-ctrl.local'.
2. Then 'ping' to the control hostname of the system controller from the Windows Command Prompt with a PC that is on the same network as the system controller and has an IP-address in the same range, and supporting DNS-SD.
  - For example, the system controller with control hostname PRASCL-0b4864-ctrl.local appears to have an IP-address 169.254.164.232. Hostnames are case-insensitive.

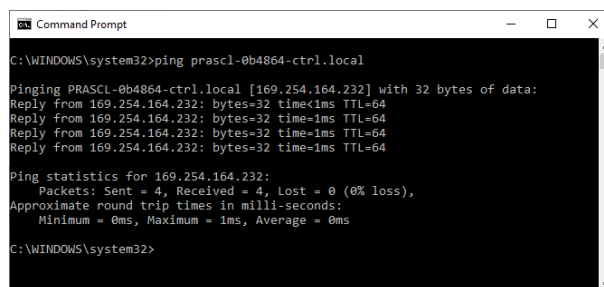

- The control C MAC-address that belongs to this IP-address will be added into the ARP (Address Resolution Protocol) table of the PC. Enter the command 'arp -a' to look into this table. Look for the IP-address that was found by pinging the control hostname, 169.254.164.232, and check its Physical Address: 00-1c-44-0b-50-32. This is the C MAC-address of this system controller.

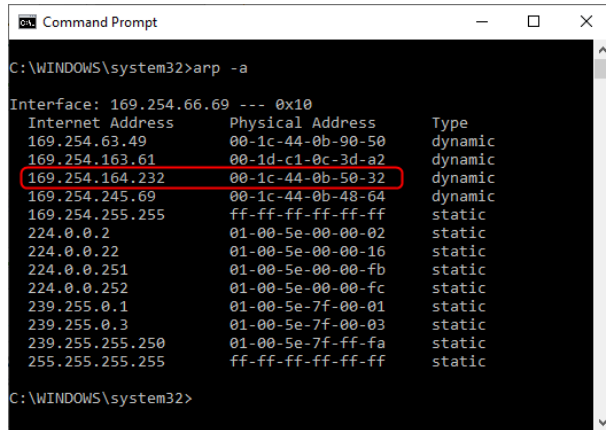

- Now login to the configuration web page of the Ethernet switch, in this case the PRA-ES8P2S, an OEM variant of the Advantech EKI-7710G. Make sure that it contains firmware that supports client MAC settings, like the firmware file EKI-7710G-2CP-AE-1-01-04.hex. Then enable the DHCP-server in the switch and define the global DHCP-server settings.

Global Information	
Information Name	Information Value
Lease time	864000 sec
Low IP Address	192.168.1.100
High IP Address	192.168.1.199
Subnet Mask	255.255.255.0
Gateway	192.168.1.1
DNS	192.168.1.1

- The next step is to go to the Client MAC Settings in the DHCP section and add the Client MAC-Address. In this example 00:1c:44:0b:50:32 (replacing the dashes for semicolons). Then enter a static IP-address for the PRAESENSA system controller outside the configured DHCP-address range, which is the range between the Low IP Address and the High IP Address of the switch. In this case the IP-address 192.168.1.99 is chosen, just below the DHCP-address range.

- After a successful entry this will show up as follows:

Entry ID	Client MAC Address	IP Address	Modify
1	00:1C:44:0B:50:32	192.168.1.99	Detail Delete

Showing 1 to 1 of 1 Entries

Previous 1 Next

- Save the new configuration and reboot the switch and all PRAESENSA equipment. Now the system controller will have a static IP-address for the configuration webpages and the Open Interface: 192.168.1.99. All other PRAESENSA devices will get an IP-address in the defined DHCP address range. The static IP-address of the system controller will not show up in the Lease Entry table anymore. For confirmation, pinging to the control hostname of the system controller will now show its new static IP-address.

## 23.5

### AVC and the positioning of Ambient noise sensors

#### The importance of Automatic Volume Control (AVC)

AVC is especially important for the audience. A properly installed and configured implementation of AVC is key to reach the required Speech Transmission Index (STI) values for emergency sound systems. The STI is the physical measure of speech transmission quality. STI uses a 0 to 1 index to indicate the degree to which a transmission channel degrades speech intelligibility. Perfectly intelligible speech, when transferred through a channel with an associated STI of 1, remains perfectly intelligible. The closer the STI value approaches 0, the more information is lost. Many installation standards for emergency sound systems prescribe an STI value above 0.5, representing a fair to excellent speech intelligibility.

Speech is a modulated signal. Speech contains noisy and tonal parts, covering the frequency spectrum between around 100 Hz and 10,000 Hz. A modulated speech signal has an associated modulation spectrum: the range of amplitude modulation frequencies applied by the human vocal system stretches from roughly 0.5 to 30 Hz.

In almost every case, loss of modulations, meaning a decrease of modulation depth, is equivalent to loss of intelligibility. Ambient noise creates a lower boundary that limits the available modulation depth. The only way to increase the available modulation depth, and thus the speech intelligibility, is to increase the signal level. AVC adjusts the announcement level sufficiently above the ambient noise level in order to maintain an adequate speech modulation depth for good intelligibility.

#### Installation of the Ambient noise sensor or sensors

Install the ambient noise sensors in each zone in a location that allows for the most representative detection of the ambient noise level. PRAESENSA uses a sample-and-hold principle for the noise measurement to set the level of calls. The ambient noise level is continuously measured, but the call level is determined by the ambient noise level and its fluctuations just before the call. During the call, the level remains constant. In this way, the AVC for calls is not affected by the sound coming from the PA loudspeakers. However, if the AVC is enabled for BGM, the BGM level is determined by the measured noise level during BGM playback. If needed, the BGM is continuously adjusted. The system needs to act on the ambient noise coming from the noise sources and not on the BGM sound coming from the loudspeakers. As such, the sensor location depends on the speaker placement and on the acoustical characteristics of the space where the sensor is located. Due to this complexity, rules to define exactly where sensors must be installed do not exist.

Install the ambient noise sensors in the so-called reverberant or diffuse field of the noise sources. The location should be where the contribution of the reflections is higher than the contribution of the direct sound from a noise source. If the sensor is in the direct field of a noise source, the measured level of the noise source is determined mostly by:

- The level of the direct sound, which is highly dependent on the noise source location
- The distance between the sensor and the noise source.

The critical distance is defined as the distance at which the direct and diffuse sound contributions are equal. The critical distance depends on:

- The geometry and absorption of the space in which the sound waves propagate
- The dimensions and shape of the sound source.

These parameters are also frequency dependent, so the critical distance varies with the frequency of the sound. The more reverberant the room is, the shorter the critical distance is from the sound source. The more absorbent the room is, the longer the critical distance is from the sound source. In the near field of a noise source, the measured noise level falls off 6 dB for every doubling of the distance. At the critical distance from the noise source, the level is only 3 dB below the level at half that distance from the noise source. Beyond the critical distance, in the reverberant field, the measured noise level hardly changes when the measurement microphone moves away from the noise source. In the reverberant field, the measured noise level is a good representation of the ambient noise level in the zone.

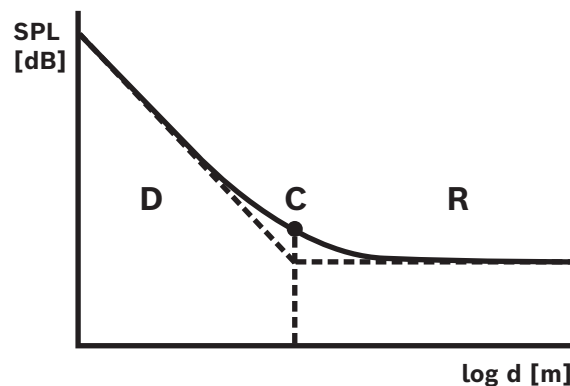

D	Direct field	R	Reverberant field
C	Critical distance	d	Distance from source

The critical distance for a diffuse approximation of the reverberant field is:

$$d_{\text{critical}} = 0.141 (\gamma S)^{1/2}$$

y	The directivity of the source. $\gamma = 1$ for an omnidirectional source.
S	The equivalent absorption surface in $\text{m}^2$ . The absorption surface is the surface area of the hall (walls, floor, and ceiling) times the average absorption of the surfaces.

On average, the relation between the volume (V) of a hall and its equivalent absorption surface (S) is:

$$S = 2.2 V^{2/3}$$

Most ambient noise sources can be considered omnidirectional. Then  $\gamma = 1$  and both equations combined yield:

$$d_{\text{critical}} = 0.21 V^{1/3}$$

The graph shows this relationship:

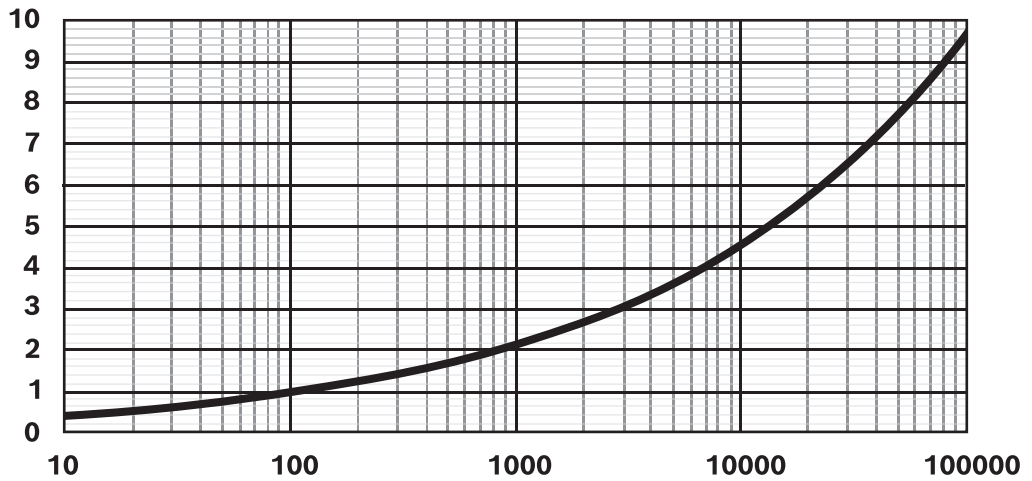

The line shows the critical distance (0 – 10 m) as a function of the volume of the hall (10 – 100,000 m³) with average absorption. For more reverberant halls, move the line downwards. For more absorbent halls, move the line upwards.

When you install a sensor in an indoor ceiling, a rule of thumb for the coverage area of a single noise sensor is:

$$A = 20 h^2$$

A	The floor coverage area
h	The ceiling height

If this area is enclosed by walls (a hall with floor area A and ceiling height h), the critical distance is approximately h/2. If the hall is bigger, the critical distance becomes more than half of the ceiling height. In this case, more noise sensors should be used.

Example: when the ceiling height is 6 m, the coverage area of a sensor installed in the ceiling is roughly 720 m².

**Practical guidelines**

The most representative position for a sensor depends heavily on the local conditions and must be decided on a case-by-case basis. In addition to the dimensions and the usage of the premises, also consider how this usage can change over time.

Some practical guidelines are:

1. **Place the ambient noise sensor far enough away from the audience so as to not capture individual conversations.**

In most systems, the ambient noise that is detected is due to crowds of people moving into and out of the zone. If a sensor is placed too close to the crowd, it will pick up on the direct sound of individual conversations. The system will adjust the level only due to isolated conversations. Install the sensor where it will pick up the cumulative level of all conversations in the space, typically in the reverberant field.

Multiple sensors can be assigned to a single zone to help prevent over-reaction to the

presence or absence of a noise source in one specific part of the zone. PRAESENSA's AVC-algorithm acts on the highest level that is detected by any of the sensors that are assigned to a specific zone. As such, the AVC avoids that the sound level in the zone drops because of a quiet moment around one of the sensors. In this way, it gives a better performance than just averaging the contribution of all sensors. Using a relatively slow response time for the AVC also helps to avoid over-reaction to short bursts of noise, like from a screaming child.

2. **Do not place a sensor near machinery or equipment that is used for heating, for ventilation and for air conditioning (HVAC).**

The mechanical noise of equipment or the noise from moving air may reach the sensor and give a wrong impression of a higher ambient noise level.

3. **Install the sensor in a centralized location within the zone to minimize the impact of audio from adjacent zones.**

If the sensor is too close to the edge of a zone, the level can be adjusted based on sounds from the adjacent zone.

4. **In spaces with high ceilings, install the sensor along a sidewall at a location 2 to 4 m above the listener.**

In spaces with high ceilings, the ambient noise level near the top of the ceiling does not match the noise changes near the floor. Although the sensor is in the reverberant field, in this type of space, a sensor located in the high ceiling may lose its effectiveness. This problem is compounded when multiple zones are included in the same high-ceiling area. In this case, the ambient noise level is a culmination of the noise from all the zones in the space. Therefore, it is usually best to install the sensors on a sidewall or on a support column, closer to the noise source. To prevent it from acting on individual conversations, install the sensor 2 to 4 m above the audience, or 4 to 6 m above the floor. If needed, use multiple sensors.

When AVC is also used for BGM:

1. **The distance between the sensor and the audience should be less than the distance between the sensor and the nearest loudspeaker.**

In most installations, the sensor will be placed in the ceiling located in the zone that it will control. When sensors are placed too close to the loudspeaker, the direct sound from the loudspeaker effectively masks the ambient noise. Then the sensor cannot track the ambient noise level accurately.

2. **Place the sensor towards the middle of the zone with nearly equal distance between the sensor and immediately adjacent loudspeakers.**

If a sensor is located too close to any one speaker, the BGM sound from that speaker could easily mask the ambient noise level. Since a sensor is usually installed in a zone with many loudspeakers, install the sensor where it is nearly equidistant from the immediately adjacent loudspeakers.

When an ambient noise sensor is used outdoors:

- **Outdoors, install the sensor 4 to 6 m above the floor on a pole or along a wall.**

In case of outdoor installation, the ambient noise sensors will be most likely in the direct sound field of the noise sources. Fewer sound reflections and reverberation occur outside of a completely enclosed space. In this case, install the sensors closer to the noise source. If the noise is due to crowds of people, install a sensor 4 to 6 meters above the floor where the crowd will be present. In case of moving crowds, use more than one sensor to cover the area, approximately 10 to 30 m apart.



## 23.6 Resilience of EOL-supervision for high frequency tones

The basis of the end-of-line supervision of loudspeaker lines is the detection of a low-level 3 VRMS pilot tone of 25.5 kHz by the PRA-EOL, with feedback to the amplifier using the loudspeaker line itself.

The prolonged high-level, high-frequency content of audio signals can mask the pilot tone detection and feedback. This can cause false positive line supervision faults. This does not happen for business calls, background music, and attention and alarm tones, because of the spectral content of these signals and of the variance of the signal. Disturbing tones are not present at a sufficiently high level to cause masking, or their presence is only momentary. The EOL-supervision process will recover automatically in time.

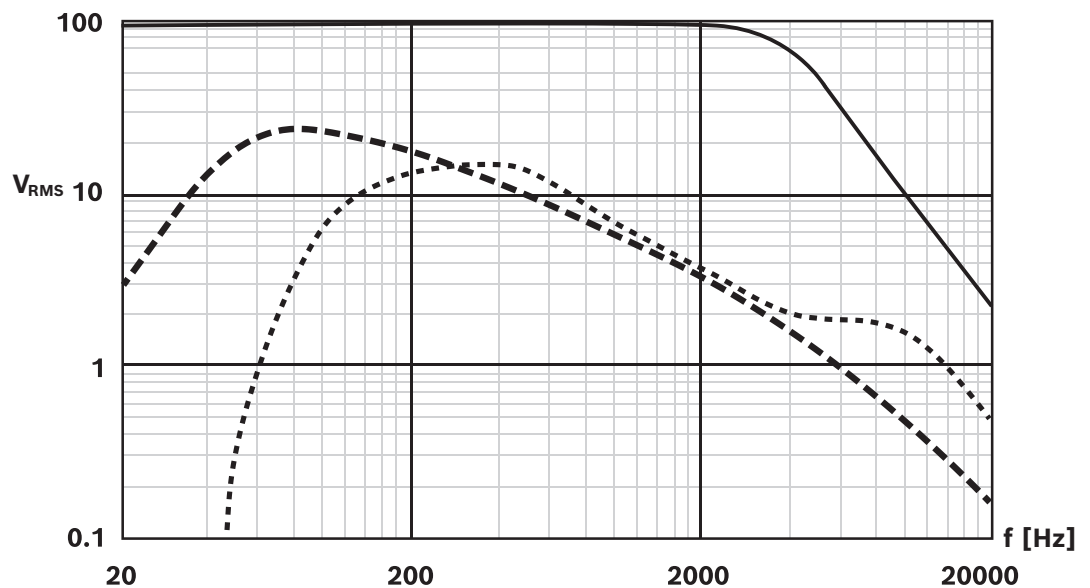

The graph shows:

- Solid line: The maximum RMS-voltage [V] of a sine wave signal on an amplifier output that does not disturb EOL-supervision. Above 2 kHz, the maximum permitted level for a continuous sine wave signal decreases. Signals with a long-lasting (multiple seconds) combination of frequency and amplitude above this line can generate false positive line supervision faults. This line is a typical case, because the sensitivity to masking signals also depends somewhat on the length and type of loudspeaker cable.
- Dashed line: The long-term average spectrum of music, based on many thousands of music tracks, all normalized to 100 % (peaks at clipping level) in a 100 V setting. More than 90 % of all tracks stay below this line. Music does not disturb EOL-supervision. In a 70 V setting the margin is even bigger, because the dashed line will move downwards by 3 dB.
- Dotted line: The long-term average spectrum of speech. This is the spectral envelope of many male and female voices in various languages. The speech signals are normalized to 100 % (peaks at clipping level) in a 100 V setting. Speech signals do not disturb EOL-supervision, because high-frequency level too low and speech signals are very dynamic by nature. Spectral peaks do not last long enough to cause trouble.



**Notice!**

Test tones are exceptional because they are typically continuous and can contain offending high-frequency tones. For instance, the PRAESENSA test tones ‘Test\_Loudspeaker\_AB\_20kHz\_10s.wav’ and ‘Test\_Loudspeaker\_AB\_22kHz\_10s.wav’ are sine wave tones of 20 kHz and 22 kHz respectively. They are used to drive the loudspeakers of the A-group and the B-group of a zone simultaneously with an inaudible signal to check if each loudspeaker is correctly connected. The wav-files of these tones have an RMS-level of -23 dBFS, corresponding to a maximum amplifier output level of 10 VRMS in a 100 V setting. This is above the solid line in the graph. These tones will disturb EOL-supervision. When false positive line supervision faults should not occur during these measurements, the tone level must be set to -20 dB in the call definition. However, detection of these tones with a simple smartphone spectrum analyzer can become more difficult.



**Notice!**

In general, do not use audio signals with an embedded high frequency pilot tone. This tone can interfere with PRAESENSA’s own pilot tone of 25.5 kHz. When audio signals are used in a system that still contain a pilot tone, it might help to notch out this tone with one of the parametric equalizer sections of the amplifier channel.

### 23.7

## Lightning protection for loudspeaker cables

Public Address and Voice Alarm systems can use very long 70 V or 100 V loudspeaker lines that also go outdoors. Risk and damage assessment can reveal that these lines require protection measures against lightning strikes and induced surges. Under those conditions, use two-pole surge arresters that can handle the maximum RMS voltage on the loudspeaker lines with some margin. A good choice is between 150 V and 300 V. The current rating of most arresters is sufficiently high for loudspeaker lines. The short circuit current of PRAESENSA amplifiers is < 12 A. The arrester must have a high discharge capacity, for instance by a combination of a gas discharge tube (GDT) and zinc oxide varistors. Their capacitance, typically < 500 pF, is low enough not to interfere with the loudspeaker line supervision. The leakage current through the earth connection is low enough not to interfere with the ground short supervision. Connect all earth connections of the surge arresters to a nearby common potential point.

Good examples are the two-pole surge arresters from the DEHNrail modular series. These arresters are built with a base part for DIN-rail mounting and a plug-in protection module:

- DR M 2P 150 (953 204) for 150 V with replaceable module DR MOD 150 (953 014)
- DR M 2P 255 (953 200) for 255 V with replaceable module DR MOD 255 (953 010)

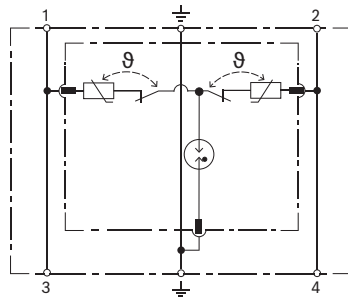

## 24 Troubleshooting

There are many possible causes for anomalous system behavior. In this section some are presented with maintenance actions focused on finding and solving the cause. In large systems it can be difficult to find the root cause of a problem. In that case it is often helpful to create a minimum size system with only the troubled device and the necessary devices to make it work, using short and proven cables. If the problem is absent, extend the system in steps until the problem shows up again.



### Notice!

Experience and analysis of repair shop data has revealed that in most cases system malfunction is not caused by defective devices, but by wiring errors, configuration errors and application errors. Read the product documentation carefully, especially the installation manual, the configuration manual and the release notes. If possible, use the latest software version (available as free download).

- **No system response**
  - **Cause:** RSTP is switched off in the System settings, but there are loops in the network. This may result in a data broadcast storm that takes the entire network down.
  - **Action:** Recovery is only possible by disconnecting redundant loops and power cycle the whole system. It is not possible to leave the loops in the network and enable RSTP, because the system controller cannot be accessed to change the configuration.
- **Some or all devices are disconnected from the system controller**
  - **Cause:** Wrong Pre-Shared Key (PSK) is loaded into one or more of the devices.
  - **Action:** Login to the system controller and verify connected devices. Modify the PSK user name and key to correct the configured PSK. In case the PSK is not available anymore, the concerning devices need to be reset to factory default via the local reset key on the device.
  - **Cause:** Not all devices have the same firmware version uploaded.
  - **Action:** Check via the Firmware Upload Tool whether all devices have the same firmware and upload the correct version.
  - **Cause:** The number of looped through devices (hop count) is more than 21, start counting from the spanning tree root bridge.
  - **Action:** Reduce the number of looped through devices by changing the network topology. Make sure that no 3rd party Ethernet switch is used with default settings, because it will have a higher priority than the PRAESENSA devices or switches and thus take the role of spanning tree root bridge.
  - **Cause:** Failing or unreliable network connections.
  - **Action:** Make sure that the maximum length of an Ethernet link is not exceeded (100 m for copper connections), that no sharp bends are made in the cabling, that the maximum length of fiber connections is not exceeded, that SX and LX fiber converters are not mixed up, that the correct type of fiber is used for the mounted converters.
- **Devices not visible in Firmware Upload Tool**
  - **Cause:** No security user present (PSK user name and key).
  - **Action:** Use secure connection via File menu and add the security user (PSK user name and key). In case the PSK is not available anymore, the concerning devices need to be reset to factory default via the local reset key on the device.

- **Music control not available on a call station**
  - **Cause:** The Music function is not enabled in Device Options of that call station.
  - **Action:** Enable the Music function for that call station. If the music source is connected to that call station, then also configure a BGM channel for the Audio input of that call station in Zone definition > BGM routing.
- **One or more amplifiers are not powered on**
  - **Cause:** The amplifier does not receive power from the multifunction power supply or power supply module.
  - **Action:** Make sure the power supply is powered, that the power supply wiring is connected correctly and that power supply outputs are enabled in the configuration.
- **The system controller is not powered on**
  - **Cause:** The system controller does not receive power from the multifunction power supply or power supply module.
  - **Action:** Make sure the power supply is powered, that the power supply wiring is connected correctly and that power supply outputs are enabled in the configuration.
- **One or more call stations are not powered on**
  - **Cause:** The call station does not receive PoE-power from the multifunction power supply or switch.
  - **Action:** Make sure the power supply or switch is powered and that at least one of the call station Ethernet cables is connected to a port that provides PoE. The second port of the call station will not provide PoE power to a subsequent call station.
- **The yellow fault indicator on one of the devices lights up**
  - **Cause:** There can be many reasons.
  - **Action:** A good way to start is to check the system fault log or the fault menu on the call station for a more detailed fault description.

## 25 Maintenance and service

The PRAESENSA system requires minimum maintenance. To keep the system in good condition, see the following sections.

### 25.1 Preventive maintenance

#### Cleaning

Wipe clean only with a dry or damp cloth.



#### Notice!

Do not use alcohol, ammonia or petroleum solvents or abrasive cleaners to clean the devices.

Depending on the pollution degree in the operating environment, check at regular intervals that the air inlets for ventilation on the front side of the rack mount devices are not obstructed by dust. Use a dry cloth or a vacuum cleaner to remove dust.

#### Operate devices within specifications

When designing the PRAESENSA system, Bosch largely avoided using wear parts. The parts subject to wear and tear are dimensioned to last longer than the lifetime of the products when they are operated normally. Operate the devices within their specifications. Relays and fans are electromechanical components and are subject to natural wear. The relays in the amplifiers are used for spare channel switching and loudspeaker group A and B switching in case of failures. During normal operation the relays are hardly ever switched and the relays have a very long lifetime. The fans in the amplifiers and multifunction power supplies are temperature controlled and run on low speed most of the time, minimizing wear.

#### Battery replacement

The system controller has an internal lithium coin cell battery, model CR2032 (3 V, 225 mAh), in a battery holder. It is only used to power the internal real time clock (RTC) when the system controller is off. The life-time of the battery is in that case more than 20 years. When the system controller is on, the RTC is powered from the external power supply and the CR2032 battery is not used, making the system insusceptible to spring contact bounce of the battery holder in case of heavy vibrations.

See also *Internal battery*, page 82.

#### Software updates

Bosch continually works on improving and developing the software. Regularly check whether there is a new version of the software that provides additional benefits. Information and software downloads are available on the Bosch PRAESENSA product pages on the internet ([www.boschsecurity.com](http://www.boschsecurity.com)).

#### Regular maintenance

Regularly (e.g. twice per year, or following local legislation) check the correct operation of the complete system, especially when the system is used as voice alarm system only without regular announcements or background music in the zones.

- Check for changes in room occupation, requiring different sound settings or loudspeaker positioning.
- Check for changes of the environmental conditions and update the system if needed.
- Use the Diagnose section of the configuration webpages to:

- Check the amplifier load conditions for any changes compared to the previous measurement. A new load measurement will result in audible test tones in the zones under test. Preferably do the measurement when the zones are not occupied or announce upcoming tests to the occupants.
- Check the battery impedance of all connected batteries for any change compared to the previous measurement. This allows for timely detection of battery aging.

## 25.2 Corrective maintenance

In case of fault reports, a qualified technician should perform:

- Fault analysis;
- Elimination of the part that causes the failure;
- Replacement of the part;
- Test of the associated functions.

## 25.3 Device replacement

In case one of the PRAESENSA devices in a system needs to be replaced, it is important to follow a strict sequence of actions to minimize down-time of the system or part of the system. The required actions differ per type of product.

### 25.3.1 System controller

To replace a defective system controller PRA-SCx in a running system proceed as follows:

#### Prepare the new system controller

1. Unpack the new system controller.
2. Supply power to the new system controller using any available 24 VDC power supply (e.g. a PRA-PSM24 or a PRA-MPSx with an unused 24 V output).
3. Connect a (laptop) PC to the new system controller.
4. Start the PRAESENSA Firmware Upgrade Tool (FWUT) and upgrade the new system controller to the required firmware version; this is the same version as the system is running in which this system controller will be used.
  - See the PRAESENSA configuration manual.
5. If the original configuration backup file and the message files are available on the installation PC, including the security keys, upload the system configuration backup file and the individual message files to the new system controller.
  - See the PRAESENSA configuration manual.

#### Exchange the system controller

1. Disconnect all cables from the original system controller.
2. Remove the original system controller from the rack and put the new system controller in the rack.
3. Connect all cables to the new system controller.
4. Connect the PC to the system, either to a spare port of the system controller or to one of the PRA-MPSx.
5. Depending on the availability of a backup configuration:
  - In case the backup from the old system was uploaded to the new system controller, update the configuration with the correct hostname of the new system controller.
  - In case no backup was available, start a new system configuration as described in the PRAESENSA configuration manual.
6. Restart the application on the new system controller.
7. Perform a system test.

8. Make a backup of the new configuration and store on a safe location.

## 25.3.2

### Amplifier

To replace a defective amplifier PRA-AD60x in a running system proceed as follows:

#### How to prepare the new amplifier

1. Unpack the new amplifier (same model as the one to be replaced).
2. Supply power to the new amplifier using any available 48 VDC supply (e.g. a PRA-PSM48 or a PRA-MPSx with an unused 48 V output).
3. Connect a (laptop) PC to the new amplifier.
4. Start the PRAESENSA Firmware Upgrade Tool (FWUT) and upgrade the new amplifier to the required firmware version; this is the same version as the original amplifier was using.
  - See the PRAESENSA configuration manual.

#### How to replace the amplifier

1. Disconnect all cables from the original amplifier:
  - First disconnect the lifeline connector. There is no audio signal on the lifeline input.
  - Then disconnect the Ethernet cables. The network link is lost, so the disconnected lifeline input is activated.
2. Then disconnect the 48 VDC connectors. There is no audio signal, so the supply current is low, reducing arc flashes.
  - Finally disconnect the audio outputs; make sure the loudspeaker cables are labeled correctly.
3. Remove the original amplifier from the rack and put the new amplifier in the rack.
4. Connect all cables to the new amplifier:
  - First connect the lifeline, Ethernet and loudspeaker cables; make sure the loudspeaker cables are connected to the appropriate channel outputs. The amplifier is in sleep mode.
  - Then connect the 48 VDC connectors. The DC/DC converters are disabled, but the inrush current to charge the input capacitors may still cause a spark.
5. Connect the PC to the system, either to a spare port of the system controller or to one of the PRA-MPSx.
6. In the PRAESENSA software, in the **System composition** page, click **Rediscover** to discover the new amplifier.
  - The amplifier is now discovered but not yet assigned.
  - The location of the original amplifier is still present and shows the hostname of the original amplifier.
7. Select under **Hostname** the new hostname of the new amplifier.
8. In the **System definition** page, click **Submit** to add the device to the configuration.
9. Click **Save and restart** to store and activate the new configuration.
10. Acknowledge and reset the faults in the system. If faults associated to the amplifier can be acknowledged and reset, this means that the connection and configuration is correct.
11. The new amplifier is now operational. There is no need for measuring the connected output loads again in Diagnose > Amplifier loads, because the system controller pushes the values of the original amplifier to the new amplifier.
12. Perform a test by making calls to the zones associated with the new amplifier and check the audio presence.
13. Make a backup of the new configuration and store on a safe location.

### 25.3.3 Multifunction power supply

To replace a defective multifunction power supply PRA-MPSx in a running system proceed as follows:

#### How to prepare the new multifunction power supply

1. Unpack the new multifunction power supply (same model as the one to be replaced).
2. Supply mains power to the new device.
3. Connect a (laptop) PC to the new multifunction power supply.
4. Start the PRAESENSA Firmware Upgrade Tool (FWUT) and upgrade the device to the required firmware version; this is the same version as the original device was using.
  - See the PRAESENSA configuration manual.

#### How to replace the multifunction power supply

1. Disconnect all cables from the original device:
  - First disconnect the NTC temperature sensor. This will stop charging the battery.
  - Then disconnect the battery cables, the negative terminal first, followed by the positive terminal. Be careful not to short circuit the battery.
  - Disconnect all control input and control output connectors.
  - Disconnect all Ethernet cables.
  - Then disconnect the mains cable. All connected amplifiers will turn off and a connected system controller too, unless it is redundantly powered from another power supply.
  - Finally disconnect the 48 V cables to the amplifiers and the 24 V cables to other devices (if any).
  - If present, remove the FSP fiber transceiver from the original device for re-use.
2. Remove the original multifunction power supply from the rack and put the new device in the rack.
3. Connect all cables to the new device:
  - First connect the 48 V from the amplifiers and the 24 V cables (if any).
  - Then connect the mains cable. The amplifiers and other devices (if any) will be powered.
  - Finally connect the other cables: battery cables, temperature sensor, control inputs and outputs, Ethernet cables.
  - If it was present, insert the SFP fiber transceiver and connect the optical fibers.
4. Connect the PC to the system, either to a spare port of the system controller or to one of the PRA-MPSx.
5. In the PRAESENSA software, in the **System composition** page, click **Rediscover** to discover the new multifunction power supply.
  - The multifunction power supply is now discovered but not yet assigned.
6. The location of the original multifunction power supply is still present and shows the hostname of the original device.
7. Select under **Hostname** the new hostname of the new multifunction power supply.
8. In the **System definition** page, click **Submit** to add the device to the configuration.
9. Click **Save and restart** to store and activate the new configuration.
10. Acknowledge and reset the faults in the system. If faults associated to the multifunction power supply can be acknowledged and reset, this means that the connection and configuration is correct.
11. The new multifunction power supply is now operational.
12. Perform a test by making calls to the zones associated to amplifiers powered from the new multifunctional power supply and check the audio presence.
13. Make a backup of the new configuration and store on a safe location.



## 25.3.4

### Call station

To replace a defective call station in a running system proceed as follows:

#### How to prepare the new call station

1. Unpack the new call station (same model as the one to be replaced).
2. Supply power to the call station by connecting it to a switch with PoE or a midspan adapter.
3. Connect a (laptop) PC to the switch or midspan adapter.
4. Start the PRAESENSA Firmware Upgrade Tool (FWUT) and upgrade the new call station to the required firmware version; this is the same version as the original call station was using.
  - See the PRAESENSA configuration manual.

#### How to replace the call station

1. Disconnect the Ethernet cables from the original call station.
2. Disconnect the bracket and the first loop-through cable to the call station extensions.
3. Connect the call station extensions to the new call station and mount the bracket.
4. Connect the Ethernet cables to the new call station.
5. Connect the PC to the system, either to a spare port of the system controller or to one of the PRA-MPSx.
6. In the PRAESENSA software, in the **System composition** page, click **Rediscover** to discover the new call station.
  - The call station is now discovered but not yet assigned.
  - The location of the original call station is still present and shows the hostname of the original call station.
7. Select under **Hostname** the new hostname of the new call station.
8. In the **System definition** page, click **Submit** to add the device to the configuration.
9. Click **Save and restart** to store and activate the new configuration.
10. Acknowledge and reset the faults in the system. If faults associated to the call station can be acknowledged and reset, this means that the connection and configuration is correct.
11. The new call station is now operational.
12. Perform a test by making some calls and check the audio presence.
13. Make a backup of the new configuration and store on a safe location.

## 25.3.5

### Ambient noise sensor

To replace a defective noise sensor in a running system proceed as follows:

#### How to prepare the new ambient noise sensor

1. Unpack the new noise sensor.
2. Supply power to the noise sensor by connecting it to a switch with PoE or a midspan adapter.
3. Connect a (laptop) PC to the switch or midspan adapter.
4. Start the PRAESENSA Firmware Upgrade Tool (FWUT) and upgrade the new ambient noise sensor to the required firmware version; this is the same version as the original noise sensor was using.
  - See the PRAESENSA configuration manual.

#### How to replace the ambient noise sensor

1. Disconnect the Ethernet cable from the original noise sensor.
2. Connect the Ethernet cable to the new noise sensor.
3. Connect the PC to the system, either to a spare port of the system controller or to one of the PRA-MPSx.

4. In the PRAESENSA software, in the **System composition** page, click **Rediscover** to discover the new noise sensor.
  - The noise sensor is now discovered but not yet assigned.
  - The location of the original noise sensor is still present and shows the hostname of the original noise sensor.
5. Select under **Hostname** the new hostname of the new noise sensor.
6. In the **System definition** page, click **Submit** to add the device to the configuration.
7. Click **Save and restart** to store and activate the new configuration.
8. Acknowledge and reset the faults in the system. If faults associated to the noise sensor can be acknowledged and reset, this means that the connection and configuration is correct.
9. The new noise sensor is now operational.
10. Perform a test by making some calls with different amounts of background noise to check the audio levels. Because the sensitivity tolerance of all PRA-ANS noise sensors is < 2 dB, the offset value of the original noise sensor can be maintained.
11. Make a backup of the new configuration and store on a safe location.

### 25.3.6

#### Control interface module

Replace a defective control interface module in a running system.

##### How to prepare the new control interface module

1. Unpack the new module.
2. Supply power to the module by connecting it to a switch with PoE or to a midspan adapter.
3. Connect a (laptop) PC to the switch or midspan adapter.
4. Start the PRAESENSA Firmware Upgrade Tool (FWUT).
5. Upgrade the new module to the same firmware version the original control interface module was using.
  - See the PRAESENSA configuration manual for details.

##### How to replace the control module

1. Disconnect the Ethernet cable(s).
2. Disconnect the control input and output connectors from the original control interface module.
  - Leave the control input wires and control output wires in the connectors.
3. Connect the Ethernet cable(s) to the new control interface module.
4. Insert the wired control input and output connectors of the old module into the new module.
5. Connect the PC to the system, either to a spare port of the system controller or to one of the PRA-MPSx.
6. In the PRAESENSA software, in the **System composition** page, click **Rediscover** to discover the new control interface module.
  - The interface module is now discovered but not yet assigned.
  - The location of the original control interface module is still present and shows the hostname of the original module.
7. Select under **Hostname** the new hostname of the new control interface module.
8. In the **System definition** page, click **Submit** to add the device to the configuration.
9. Click **Save and restart** to store and activate the new configuration.
10. Acknowledge and reset the faults in the system. If the faults associated with the control interface module can be acknowledged and reset, the connection and configuration is correct.

11. The new control interface module is now operational.
12. Test the new control interface module by activating some inputs and outputs and check for proper functioning.
13. Make a backup of the new configuration and store on a safe location.

### 25.3.7

#### Wall control panel

To replace a defective device in a running system proceed as follows:

##### How to prepare the new wall control panel

1. Unpack the new device.
2. Connect the control panel to a switch with PoE or to a midspan adapter to supply it with power.
3. Connect a (laptop) PC to the switch or midspan adapter.
4. Start the PRAESENSA FWUT to upgrade the new device to the same version as the original device.
  - Refer to the chapter *Check/Upload the devices firmware* in the PRAESENSA configuration manual.

##### How to replace the wall control panel

1. Disconnect the Ethernet cable from the original device.
2. Connect the Ethernet cable to the new wall control panel.
3. Connect the PC to the system, either to a spare port of the system controller or to one of the PRA-MPSx.
4. In the PRAESENSA software, in the **System composition** page, click **Rediscover** to discover the new wall control panel.
  - The control panel is now discovered but not yet assigned.
  - The location of the original control panel is still present and shows the hostname of the original device.
5. Select under **Hostname** the hostname of the new device.
6. In the **System definition** page, click **Submit** to add the device to the configuration.
7. Click **Save and restart** to store and activate the new configuration.
8. Acknowledge and reset the faults in the system.
  - The connection and configuration is correct if the faults associated to the device are acknowledged and reset.
9. The new wall control panel is now operational.
10. Perform a test and observe if the sound in the zone is as expected:
  - Select different background music channels.
  - Adjust the volume level.
11. Make a backup of the new configuration and store it in a safe location.

## 26 EN 54-16 / EN 54-4 compliance

Compliance to the standards EN 54-16 and EN 54-4 requires certain installation and configuration directions to be adhered to.

### 26.1 Introduction

The Bosch PRAESENSA system is designed to operate as a VACIE (Voice Alarm Control and Indicating Equipment), providing emergency announcement functions in accordance with the requirements of international standards, while also providing functions for business announcement and background music.

The PRAESENSA VACIE includes one or more system controllers, multi-channel amplifiers, desktop and wall mount emergency call stations, uninterruptable power supplies and network switches.

Installers of the PRAESENSA VACIE shall review and understand the architecture and the installation and configuration processes of PRAESENSA in order to build up the PRAESENSA VACIE in compliance with EN 54-16 and EN 54-4. This information is available in the PRAESENSA installation manual, with focus on the hardware, and the PRAESENSA configuration manual, with focus on the software.

### 26.2 Checklist

The EN 54-16 / EN 54-4 compliance checklist gives installation and configuration directions for compliance to these standards. Each section of the checklist must be approved after installation for compliance (Y/N-field).

EN 54-16 / EN 54-4 compliance checklist	
<b>System architecture and compliance</b>	Y/N:
<p>PRAESENSA is a networked sound system in which all system elements are connected via OMNEO, the secure Bosch network protocol for audio and control on Ethernet. A system comprises several system elements, or devices. Some devices are intended for business operation only; they can be part of the PRAESENSA system, but should not be used for VACIE-functions in compliance to EN 54-16 and EN 54-4.</p> <p>The Certificate of Constancy of Performance, 0560-CPR-182190000, issued by the Notified Body, applies to the construction product PRAESENSA VACIE, in compliance with Regulation 305/2011/EU of the European Parliament and of the Council of 9 March 2011, the Construction Products Regulation or CPR. All devices that are listed in this Certificate of Constancy of Performance can be used in the VACIE. As per July 2023, these are: PRA-SCL, PRA-SCS, PRA-AD604, PRA-AD608, PRA-EOL, PRA-MPS3, PRA-CSLD, PRA-CSLW, PRA-CSE, PRA-IM16C8, PRA-ES8P2S (Advantech EKI-7710G-2CP), PRA-SFPSX (Advantech SFP-GSX/LCI-AE), PRA-SFPLX (Advantech SFP-GLX/LCI-10E), PRA-LID (Hacousto LDB), PRA-LIM (Hacousto FIM), OMN-ARNIE (Advantech ARK 1123 C-CTOS-ENNLBO02-M4), OMN-ARNIS (ARK1123 C-CTOS-ENNLBO02-M5), Mean Well DDR-60L-12, CISCO IE-5000-12S12P-10G, CISCO PWR-RGD-LOW-DC-H, CISCO SFP-10G-LR, CISCO GLC-LX-SM-RGD.</p> <ul style="list-style-type: none"> <li>- Understand the purpose of each device element and its function in the system. See section <i>System introduction</i>, page 19.</li> <li>- Familiarize with the requirement clauses of the EN 54-16 and EN 54-4 standards.</li> </ul> <p>The following optional functions, with requirements, are included in PRAESENSA:</p> <ul style="list-style-type: none"> <li>- Audible warning (7.3)</li> </ul>	

<b>EN 54-16 / EN 54-4 compliance checklist</b>	
<ul style="list-style-type: none"> <li>- Phased evacuation (7.5)</li> <li>- Manual silencing of the voice alarm condition (7.6.2)</li> <li>- Manual reset of the voice alarm condition (7.7.2)</li> <li>- Output to fire alarm devices (7.8)</li> <li>- Voice alarm condition output (7.9)</li> <li>- Indication of faults related to the transmission path to the CIE (8.3)</li> <li>- Indication of faults related to voice alarm zones (8.4)</li> <li>- Voice alarm manual control (10)</li> <li>- Interface to external control device(s) (11)</li> <li>- Emergency microphone(s) (12)</li> <li>- Redundant power amplifiers (13.14)</li> </ul> <p>The following optional functions, with requirements, are not included in PRAESENSA:</p> <ul style="list-style-type: none"> <li>- Delay(s) to entering the voice alarm condition (7.4)</li> <li>- Disabled condition (9)</li> </ul>	
<b>Installation and location</b>	Y/N:
<p>The Bosch PRAESENSA VACIE must be installed and commissioned by those who have completed the appropriate training courses conducted by Bosch Security Systems. Once the installation and commissioning process is complete, access to the VACIE is restricted to authorized personnel only.</p> <ul style="list-style-type: none"> <li>- Install equipment on locations in accordance with the access levels and provide appropriate access restrictions. See section <i>Location of racks and enclosures</i>, page 25.</li> <li>- Make sure the location of the installation has sufficient ventilation to remove the generated heat of the equipment. See section <i>Mounting the 19"-rack devices</i>, page 27.</li> </ul> <p>For standards compliance of the PRAESENSA VACIE, the devices, the interconnections to the Fire Detection System, network infrastructure, loudspeakers and loudspeaker wiring must be installed in accordance with the provisions of applicable standards and the directions provided in the Bosch PRAESENSA installation manual.</p> <ul style="list-style-type: none"> <li>- Use compliant equipment racks and cabinets only. See section <i>Equipment racks and cabinets</i>, page 27.</li> <li>- Obey the cabling requirements and recommendations. See section <i>Cable requirements</i>, page 29.</li> </ul> <p>Dual redundant interconnections must be used between system elements in separate cabinets or racks; within a rack it is recommended to use dual redundant interconnections.</p> <ul style="list-style-type: none"> <li>- Use the A and B power supply connections of all devices.</li> </ul>	
<b>Network</b>	Y/N:
<p>Use a separate Ethernet network for PRAESENSA, not shared with other services, and do not use other network switches than the PRA-ES8P2S.</p> <ul style="list-style-type: none"> <li>- Respect the maximum system size. See section <i>System size limits</i>, page 36.</li> <li>- Do not deviate from recommended network switch settings and loop length. See section <i>Network switches</i>, page 37.</li> <li>- Use shielded network cabling. See section <i>Cable requirements</i>, page 29.</li> <li>- Connect networked devices in a loop, with RSTP enabled.</li> </ul> <p>In case continuous event logging (beyond the possibilities and capacity provided by the system controller) is required, a logging PC must be installed on the PRAESENSA network. In that case the logging PC is considered as a basic element of the system.</p>	

<b>EN 54-16 / EN 54-4 compliance checklist</b>	
<b>Ethernet switch</b>	Y/N:
<p>The VACIE can use additional Ethernet switches for flexibility of the system connection topology.</p> <ul style="list-style-type: none"> <li>– Do not use other switches than the PRA-ES8P2S. Refer to <i>Ethernet switch (ES8P2S)</i>, page 251.</li> <li>– Do not use other fiber transceivers than the PRA-SFPLX and PRA-SFPSX. Refer to <i>Fiber transceiver (SFPLX, SFPSX)</i>, page 260.</li> <li>– When a PRA-ES8P2S is used in a PRAESENSA system with a software version V1.42 or lower, its fault output contact must be connected to a PRAESENSA control input, configured as <b>External fault input</b>. Refer to <i>Fault relay connection</i>, page 256. In a PRAESENSA system with a software version V1.50 or higher, the system controller supervises the switch through SNMP V3, over the network. The PRA-ES8P2S must have firmware version 1.01.05 or higher. The fault output contact is not used.</li> <li>– The PRA-ES8P2S must be powered from a 48 V output of a PRA-MPS3 with battery backup. Refer to <i>Power supply connection</i>, page 255.</li> </ul>	
<b>Emergency call station</b>	Y/N:
<p>The call stations PRA-CSLD or PRA-CSLW must be used in combination with one or more PRA-CSE call station extensions. Such a composed call station provides visible (LEDs, LCD) and audible (buzzer) indicators to unambiguously indicate the quiescent condition, the voice alarm condition and the fault warning condition with indications of the recognized faults. The system is capable of being simultaneously in the voice alarm condition and in the fault warning condition. The optional disabled condition is not supported.</p> <ul style="list-style-type: none"> <li>– To indicate the voice alarm condition and the fault warning condition, configure the call station as an emergency call station.</li> <li>– Install an emergency call station in accordance with access level 2 and provide appropriate access restrictions. See section <i>Location of racks and enclosures</i>, page 25.</li> <li>– The emergency call station must be network-connected in a loop with PoE power supply on both network connections. See section <i>Power over Ethernet</i>, page 189.</li> <li>– Emergency call definitions must have a preconfigured priority in the emergency priority range 224 - 255. Higher priorities overrule lower priorities in case of resource or destination conflicts. In case of the same priority the first call gets priority, but for priority 255 the last call gets priority.</li> <li>– If the VACIE uses multiple emergency call stations, the priorities between them must be arranged via the call definitions in the configuration. At any time only one microphone will be active in any zone.</li> <li>– To silence an audible warning manually, the emergency call station must be configured with buttons to acknowledge and reset the fault alarm and voice alarm condition.</li> </ul>	
<b>Amplifier</b>	Y/N:
<p>The PRAESENSA power amplifiers have a built-in spare amplifier channel that takes over from a failing channel automatically.</p> <ul style="list-style-type: none"> <li>– Amplifier supervision must be enabled in the configuration.</li> </ul> <p>The amplifier to loudspeaker cabling must be supervised.</p> <ul style="list-style-type: none"> <li>– Use a PRA-EOL end-of-line device for each loudspeaker line to detect interrupted or shorted loudspeaker lines. See section <i>End-of-line device (EOL)</i>, page 124.</li> </ul>	

<b>EN 54-16 / EN 54-4 compliance checklist</b>	
<ul style="list-style-type: none"> <li>- In case of A-group and B-group wiring for a zone, use an end-of-line device for each group. See sections <i>Amplifier outputs</i>, page 94 and <i>Amplifier outputs</i>, page 112.</li> </ul>	
<b>Multifunction power supply</b>	Y/N:
<p>PRAESENSA uses multifunctional power supplies to provide power to the system devices.</p> <ul style="list-style-type: none"> <li>- Only use the PRA-MPS3 power supply with battery backup. See section <i>Multifunction power supply, large (MPS3)</i>, page 132.</li> <li>- Make sure the battery size is sufficient for the required backup and alarm time during mains failures; use the calculation directions. See section <i>Battery calculation</i>, page 55.</li> <li>- Use a 12 V VRLA battery of capacity 100 - 230 Ah, marked with the type designation and date of manufacture; use the supplied battery cables or similar for proper battery impedance measurement. See section <i>Battery and fuse</i>, page 137.</li> <li>- Use the lifeline interconnections between the multifunction power supply and the connected amplifiers to enable the snooze mode for sufficient backup and alarm time. See section <i>Lifeline</i>, page 147.</li> </ul>	
<b>VACIE control inputs and outputs</b>	Y/N:
<p>The PRA-MPS3 and the PRA-IM16C8 provide control inputs and outputs. The control inputs can be used as voice alarm inputs from the fire detection equipment, the Control and Indicating Equipment (CIE).</p> <ul style="list-style-type: none"> <li>- Control input connections for alarm purposes must be supervised, using end-of-line resistors, to detect a cable short or interruption and prevent that this is perceived as a state change. See section <i>Control inputs</i>, page 152.</li> <li>- Emergency call definitions that are triggered from a control input must have a preconfigured priority in the emergency priority range 224 - 255. Higher priorities overrule lower priorities in case of resource or destination conflicts. In case of the same priority the first call gets priority, but for priority 255 the last call gets priority.</li> <li>- To silence an audible warning from the CIE, control inputs must be configured for the function to acknowledge and reset the fault alarm and voice alarm condition.</li> <li>- PRAESENSA control outputs are floating relay contacts without the ability to supervise the control output connections. The control outputs should not be used as outputs to fire alarm devices. Use control outputs of the CIE for that purpose. See section <i>Control outputs</i>, page 154.</li> </ul>	
<b>Open interface</b>	Y/N:
<p>Next to control inputs and outputs and control via a call station with extensions, the PRAESENSA VACIE supports a TCP/IP based Open Interface with connection supervision for interfacing to external control device(s) such as standardized user interfaces required by local regulations. This interface only allows for access to level 1 and level 2 functions. Mandatory functions of the VACIE are not overridden.</p> <ul style="list-style-type: none"> <li>- An uncertified PC, connected via the Open Interface, shall not be used as the sole user interface to put the VACIE in the voice alarm condition.</li> <li>- The Open Interface is only allowed to be used as interface between a CIE and the VACIE in the case of the Smart Safety Link between the Bosch modular fire panels AVENAR panel 2000 or AVENAR panel 8000 as CIE and the Bosch PRAESENSA as VACIE.</li> </ul>	

<b>EN 54-16 / EN 54-4 compliance checklist</b>	
<ul style="list-style-type: none"> <li>– The Open Interface is allowed to be used with a PC on the same network for event logging purposes, including the possibility to acknowledge and/or reset the fault alarm condition and the voice alarm condition.</li> </ul>	
<b>Multi-subnet</b>	Y/N:
<p>A PRAESENSA system can be installed in networks across multiple subnets with multi-VLAN support. The multiple subnets are divided by a router. Refer to <i>System topologies, page 45</i>. This system design requires the use of network synchronizers in each subnet: one OMN-ARNIE Network synchronizer enterprise for the main subnet and one OMN-ARNIS Network synchronizer single for each additional subnet.</p> <ul style="list-style-type: none"> <li>– Each OMN-ARNIE or OMN-ARNIS must be powered from a 48 VDC output of the PRA-MPS3 through a Meanwell DC/DC converter, model DDR-60L-12. This will create the required uninterruptable 12 VDC supply voltage.</li> <li>– The multi-subnet topology requires a Layer 3 (L3) switch or router. For this purpose the industrial Ethernet switch CISCO IE-5000-12S12P-10G is certified with PRAESENSA.</li> <li>– It is required to have switch supervision that uses secure SNMP V3. The system controller uses SNMP V3 to supervise the CISCO IE-5000-12S12P-10G router/switch and the PRA-ES8P2S switch, with software version 1.01.05 or higher. The controller supervises their presence and power supply status, and detects defective or redundant network connections.</li> <li>– Make sure that a PRA-AD604 or a PRA-AD608 amplifier in the system is powered from a PRA-MPS3 within the same subsystem. Otherwise, its lifeline will not work. This is a requirement for EN 54-16 compliance.</li> <li>– To create an EN 54-16 certified PRAESENSA multi-subnet system, use only certified PRAESENSA products, and the additional network related products that are certified with PRAESENSA. Find these additional products listed in <i>System with devices in different subnets, page 46</i>.</li> <li>– Contact Bosch to design and configure a PRAESENSA multi-subnet system in compliance with EN 54-16, as it requires special expertise.</li> </ul>	
<b>Rack label</b>	Y/N:
<p>The proper functioning of the VACIE in accordance with EN 54-16 is the joint responsibility of the manufacturer of the system elements and the installer. The system elements and documentation for installation and configuration are reviewed, tested and certified for compliance by a Notified Body. The installer is responsible for the correct design, installation, interconnection, configuration and maintenance of the system for compliance to EN 54-16 and EN 54-4.</p> <ul style="list-style-type: none"> <li>– After installation and configuration of the PRAESENSA system, all sections of this checklist must have been positively approved. Then the VACIE rack label that is delivered with the PRAESENSA system controller must be affixed to the door of the rack containing the system controller.</li> </ul>	

**Refer to**

- *System introduction, page 19*
- *Location of racks and enclosures, page 25*
- *Mounting the 19"-rack devices, page 27*
- *Equipment racks and cabinets, page 27*



- Cable requirements, page 29
- System size limits, page 36
- Network switches, page 37
- Multifunction power supply, large (MPS3), page 132
- Battery calculation, page 55
- Battery and fuse, page 137
- Lifeline, page 147
- End-of-line device (EOL), page 124
- Amplifier outputs, page 94
- Amplifier outputs, page 112
- Ethernet switch (ES8P2S), page 251
- Fiber transceiver (SFPLX, SFPSX), page 260
- Fault relay connection, page 256
- Power supply connection, page 255
- Control inputs, page 152
- Control outputs, page 154
- Power over Ethernet, page 189

### 26.3

### Rack label

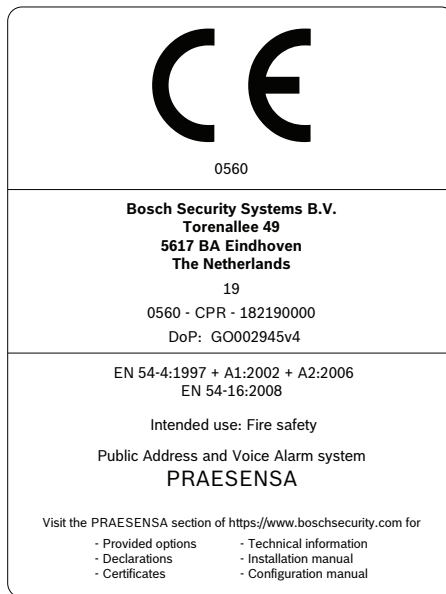

## 27 ISO 7240-16 / ISO 7240-4 compliance

Compliance to the standards ISO 7240-16 and ISO 7240-4 requires certain installation and configuration directions to be adhered to.

### 27.1 Introduction

The Bosch PRAESENSA system is designed to operate as a VACIE (Voice Alarm Control and Indicating Equipment) or s.s.c.i.e. (sound system control and indicating equipment), providing emergency announcement functions in accordance with the requirements of international standards, while also providing functions for business announcement and background music.

Because the standards ISO 7240-16 and ISO 7240-4 are very similar to the standards EN 54-16 and EN 54-4 respectively, only the additional requirements are listed in this chapter.

Installers of the PRAESENSA s.s.c.i.e. shall review and understand the architecture and the installation and configuration processes of PRAESENSA in order to build up the PRAESENSA VACIE in compliance with ISO 7240-16 and ISO 7240-4. This information is available in the PRAESENSA installation manual, with focus on the hardware, and the PRAESENSA configuration manual, with focus on the software.

### 27.2 Checklist

The installer must use the checklist for EN 54-16 / EN 54-4 (see chapter *EN 54-16 / EN 54-4 compliance, page 300*) before proceeding with this checklist for ISO 7240-16 / ISO 7240-4. The checklist for EN 54-16 / EN 54-4 compliance and this supplementary checklist for ISO 7240-16 / ISO 7240-4 combined provide the installation and configuration directions for compliance to ISO 7240-16 / ISO 7240-4. Each section of the checklist must be approved after installation for compliance (Y/N-field).

<b>ISO 7240-16 / ISO 7240-4 compliance checklist (supplementary to the EN 54-16 / EN 54-4 checklist)</b>	
<b>System compliance</b>	Y/N:
<p>ISO 7240-16:2007 specifies the requirements, test methods and performance criteria for sound system control and indicating equipment (s.s.c.i.e.) for use in buildings and structures as part of a sound system for emergency purposes (s.s.e.p.) as defined in ISO 7240-1. The s.s.c.i.e. is primarily intended to broadcast information for the protection of lives within one or more specified areas in an emergency, to effect a rapid and orderly mobilization of occupants in an indoor or outdoor area.</p> <p>ISO 7240-4:2017 specifies requirements, test methods and performance criteria for power supply equipment (PSE) for use in fire detection and alarm systems installed in buildings.</p> <p>PRAESENSA is a networked sound system in which all system elements are connected via OMNEO, the secure Bosch network protocol for audio and control on Ethernet. A system comprises several system elements, or devices. Some devices are intended for business operation only; they can be part of the PRAESENSA system, but should not be used for s.s.c.i.e.-functions.</p>	

<b>ISO 7240-16 / ISO 7240-4 compliance checklist (supplementary to the EN 54-16 / EN 54-4 checklist)</b>	
<p>The PRAESENSA sound system control and indicating equipment (s.s.c.i.e.) has been tested by a Notified Body. As per December 2023, to be in compliance to ISO 7240-16:2007 and ISO 7240-4:2017, a PRAESENSA system may use the following devices:</p> <p>PRA-SCL, PRA-SCS, PRA-AD604, PRA-AD608, PRA-EOL, PRA-MPS3, PRA-CSLD, PRA-CSLW, PRA-CSE, PRA-IM16C8, PRA-ES8P2S (Advantech EKI-7710G-2CP), PRA-SFPSX (Advantech SFP-GSX/LCI-AE), PRA-SFPLX (Advantech SFP-GLX/LCI-10E), PRA-LID (Hacousto LDB), PRA-LIM (Hacousto FIM), OMN-ARNIE (Advantech ARK 1123 C-CTOSENNLBO02-M4), OMN-ARNIS (ARK1123 C-CTOS-ENNLBO02-M5), Mean Well DDR-60L-12, CISCO IE-5000-12S12P-10G, CISCO PWR-RGD-LOW-DC-H, CISCO SFP-10G-LR, and CISCO GLC-LX-SM-RGD.</p> <ul style="list-style-type: none"> <li>- Understand the purpose of each device element and its function in the system. See section <i>System introduction</i>, page 19.</li> <li>- Familiarize with the requirement clauses of the ISO 7240-16 and ISO 7240-4 standards.</li> </ul> <p>The following optional functions, with requirements, are included in PRAESENSA:</p> <ul style="list-style-type: none"> <li>- Alert signal (7.2)</li> <li>- Audible warning (7.5)</li> <li>- Phased evacuation (7.7)</li> <li>- Silencing of the voice-alarm condition with a manual control (7.8.2)</li> <li>- Reset of the voice-alarm condition with a manual control (7.9.2)</li> <li>- Output to alarm devices (7.10)</li> <li>- Voice alarm condition output signal (7.11)</li> <li>- Faults related to the transmission path to the emergency detection system (8.2.6.1)</li> <li>- Faults related to emergency loudspeaker zones (8.2.6.2)</li> <li>- Manual mode control (11)</li> <li>- Indication of emergency-loudspeaker zones in the fault-warning condition (11.3)</li> <li>- Interface to external control device(s) (12)</li> <li>- Emergency microphone (13)</li> <li>- Microphone priority (13.2)</li> <li>- Microphone emergency-loudspeaker-zone control (13.3)</li> <li>- Redundant power amplifiers (14.14)</li> </ul> <p>The following optional functions, with requirements, are not included in PRAESENSA:</p> <ul style="list-style-type: none"> <li>- Delay to entering the voice alarm condition (7.6)</li> <li>- Disabled condition (9)</li> <li>- Disablement-condition output (9.4)</li> <li>- Test condition (10)</li> <li>- Indication of emergency-loudspeaker zones in the disabled condition (11.4)</li> </ul>	
<b>Alert and evacuate signals</b>	Y/N:
<p>Select and configure an alert signal that is in compliance with ISO 7731 from the set of available signals that PRAESENSA offers or have such a signal created as a wav-file. The preferred signal and required sound pressure level depend on the actual application, as</p>	

<b>ISO 7240-16 / ISO 7240-4 compliance checklist (supplementary to the EN 54-16 / EN 54-4 checklist)</b>	
<p>the parameters of the danger signal (signal level, frequency spectrum, temporal pattern, etc.) shall be designed to stand out from all other sounds in the reception area and shall be distinctly different from any other signals.</p> <p>The sound pressure level shall be at least 65 dBA at any position in the signal reception area, while being at least 15 dB above A-weighted ambient noise, but it may not exceed 118 dBA.</p> <p>The danger signal shall include frequency components between 500 Hz and 2500 Hz. Pulsating danger signals are preferred to signals that are constant in time, while the repetition frequencies shall be in the range from 0.5 Hz to 4 Hz. Examples of compliant multi-sinewave tones that are available for PRAESENSA are:</p> <ul style="list-style-type: none"> <li>- Alarm_MS_1200-500Hz_100%_10x1s.wav</li> <li>- Alarm_MS_970+630Hz_100%_10x(0.5+0.5)s.wav</li> </ul> <p>The evacuate signal shall include the tone signal and pre-recorded voice messages, as specified in ISO 8201. PRAESENSA offers dedicated ISO 8201 compliant evacuate signals, that have the temporal pattern as described by ISO 8201. Examples of compliant multi-sinewave tones that are available for PRAESENSA are:</p> <ul style="list-style-type: none"> <li>- Alarm_MS_800-970Hz_38%_3x(0.5+0.5)s+1s.wav</li> <li>- Alarm_MS_970Hz_38%_3x(0.5+0.5)s+1s.wav</li> </ul> <p>Make sure that the sound pressure level of the evacuate signal is at least 65 dBA, or 75 dBA if the signal is intended to arouse sleeping occupants.</p> <p>ISO 8201 does not specify pre-recorded voice messages, but PRAESENSA offers the possibility to store and select custom voice messages to satisfy specific mandated requirements. Configure a call definition to set up a sequence of tones and messages with repetition options and to assign such a call to a button or input contact to commence. Where a voice signal is used as part of the alert signal, the alert signal shall precede the first pre-recorded voice message for 3 s to 10 s. This can be accomplished by configuring an appropriate, ISO 7731 compliant, alert signal as start tone in the PRAESENSA call definition. Successive alert signals and messages shall then continue until either automatically or manually changed or silenced. This can be accomplished by configuring the appropriate alert signal and voice message as sequential messages in the PRAESENSA call definition with infinite repetitions. The voice message(s) and alert tone(s) must be short enough to make sure that the interval between successive messages does not exceed 30 s and silence periods do not exceed 10 s.</p> <p>Where an alert signal is used as part of an automatic evacuation plan, it should precede the evacuate signal and may include voice messages. Use separate call definitions for the alert and evacuate signals, with or without voice messages, and make sure that the evacuation call has a higher priority than the alert call, addressing the same zones. Upon starting the evacuation call, the alert call is automatically stopped, or interrupted when the alert call is configured to return after being overruled. See also <b>Phased evacuation</b> in this checklist.</p>	
<b>Fault warning</b>	Y/N:
<p>To indicate the fault warning condition, use one or more output contacts (on the PRA-MPS3) and configure them as Fault alarm buzzer, Fault alarm indicator and/or System fault indicator. These contacts have fail-safe behavior: when de-energized, the contacts of these outputs are closed (activated).</p>	

<b>ISO 7240-16 / ISO 7240-4 compliance checklist (supplementary to the EN 54-16 / EN 54-4 checklist)</b>	
<b>Audible warning</b>	Y/N:
<p>The audible warning shall be silenced automatically when the s.s.c.i.e. is reset from the voice alarm condition. PRAESENSA silences the audible warning signal upon acknowledge of the voice alarm condition. Combine the acknowledge and reset into a single action in the configuration to make the acknowledge implicit upon resetting the voice alarm condition.</p>	
<b>Phased evacuation</b>	Y/N:
<p>Phased evacuation can be accomplished in various ways with PRAESENSA:</p> <ul style="list-style-type: none"> <li>- By phased triggering of input contacts (configured for the function Make announcement) by the c.i.e. that start separate alarm calls to different zones. Such calls can also be started via the Open Interface.</li> <li>- By phased triggering of the same call for different zones; subsequent triggers after the first one will extend the running call with additional zones. Configure the input contact to Start phased announcement. This has the advantage that only one instance of a message player is occupied, regardless of the number of zones or zone groups that are added later.</li> </ul> <p>A (phased) call can be overruled manually by starting a call with a higher priority. The lower priority call must be configured (in its call definition) to continue after an interruption in order to resume automatically.</p>	
<b>Rack label</b>	Y/N:
<p>The proper functioning of the s.s.c.i.e. in accordance with ISO 7240-16 is the joint responsibility of the manufacturer of the system elements and the installer. The system elements and documentation for installation and configuration are reviewed, tested and certified for compliance by a Notified Body. The installer is responsible for the correct design, installation, interconnection, configuration and maintenance of the system for compliance to ISO 7240-16 and ISO 7240-4.</p> <p>After installation and configuration of the PRAESENSA system, all sections of this checklist must have been positively approved. Then the s.s.c.i.e. rack label that is delivered with the PRAESENSA system controller must be affixed to the door of the rack containing the system controller.</p>	

**Refer to**

- EN 54-16 / EN 54-4 compliance, page 300
- System introduction, page 19

## 27.3

### Rack label

<p><b>Bosch Security Systems B.V.</b> Torenallee 49 5617 BA Eindhoven The Netherlands</p>						
<p>ISO 7240-4:2017 ISO 7240-16:2007</p> <p>Intended use: Fire safety</p> <p>Public Address and Voice Alarm system <b>PRAESENSA</b></p> <p>Visit the PRAESENSA section of <a href="https://www.boschsecurity.com">https://www.boschsecurity.com</a> for</p> <table><tr><td>- Provided options</td><td>- Technical information</td></tr><tr><td>- Declarations</td><td>- Installation manual</td></tr><tr><td>- Certificates</td><td>- Configuration manual</td></tr></table>	- Provided options	- Technical information	- Declarations	- Installation manual	- Certificates	- Configuration manual
- Provided options	- Technical information					
- Declarations	- Installation manual					
- Certificates	- Configuration manual					

## 28 UL 2572 / UL 864 compliance

Compliance to the standards UL 2572 and UL 864 requires certain directions for installation and configuration to be adhered to.

### 28.1 Introduction

The Bosch PRAESENSA system is designed to provide emergency announcement functions in accordance with the requirements of international standards. The system also provides functions for business announcement and background music.

The installers of the system shall review and understand the architecture, the installation and the configuration processes of PRAESENSA. The installers will then build the PRAESENSA system in compliance with:

- UL 2572 for Mass Notification Systems (MNS), and
- UL 864 for Fire Evacuation Systems.

This information is available in the PRAESENSA Underwriters Laboratories Listing Document (ULLD). Download the document at <https://licensing.boschsecurity.com/publicaddress/html/load.htm?5000>, where you can also find the One-Page Operation Instruction for the first responder panel.

Supplemental information is available in the PRAESENSA installation manual and configuration manual.

### 28.2 Checklist

The UL 2572 / UL 864 compliance checklist gives directions for the installation and the configuration for compliance to these standards. This checklist is for informational purposes only. The ULLD is leading. Each section of the checklist must be approved after installation for compliance (Y/N-field).

<b>UL 2572 / UL 864 compliance checklist</b>	
<b>System composition</b>	Y/N:
<p>PRAESENSA only provides voice capabilities. The system relies upon the third party life safety Network access control (NAC) extenders listed to provide the visual signaling. To meet the display requirement for both Fire and Mass Notification System services, the PRA-FRP3-US operator interface of PRAESENSA must be mounted adjacent to a UL 2572 / UL 864 listed Bosch FACP, model B9512G or B8512G, that employs the display keypad model B926M that includes Fire and MNS annunciation.</p> <p>B9512G and B8512G control units provide the dedicated Fire input circuits and dedicated MNS input circuits to trigger the PRA-SCL to activate either fire or MNS signaling. Based upon the input circuit type, the B9512G and B8512G sends commands to UL-listed Altronix NAC extender model R1002ULADA, which then activates the respective Fire strobes or MNS strobes. B9512G and B8512G cannot have any audible or visual appliances connected to it.</p> <p>The Certificate of Compliance with number S35700 and the UL Follow-up Services Procedure, issued by UL LLC, applies to the PRAESENSA products described herein. These products have been investigated to, and found to be in compliance with the standards for Mass Notification Systems (UL 2572) and Fire Evacuation Systems (UL 864). The following minimum (M) and optional (O) configurations are allowed to meet the intended applications.</p>	

Order number	Product name	Mandatory / Optional	Minimum quantity	Maximum per system / product
PRA-SCL	System controller, large	M	1	Per system: 3
PRA-AD604	Amplifier, 600W 4-channel	M (at least one)	1	Per system: 150 (including all PRA-SCL and PRA-FRP3-US)
PRA-AD608	Amplifier, 600W 8-channel			
PRA-MPS3	Multifunction power supply, large	M	1	
PRA-CSLD	Desktop LCD call station	O	0	
PRA-CSLW	Wallmount LCD call station	O	0	
PRA-CSE	Call station extension	O	0	
PRA-FRP3-US	First responder panel USA, 3-extension	M	1	Per system: 20
PRA-EOL-US	End-of-line device	M	1	Per amplifier output A: 1 Per amplifier output B: 1
PRA-ES8P2S	Ethernet switch, 8xPoE, 2xSFP	O	0	Per PRA-MPS3: 3
PRA-SFPLX	Fiber transceiver, single mode	O	0	Per PRA-MPS3: 1 Per PRA-ES8P2S: 2
PRA-SFPSX	Fiber transceiver, multimode	O	0	
<b>Location of racks and enclosures</b>				Y/N:
To make sure that the standards compliance of PRAESENSA are not compromised, install the PRAESENSA devices, the interconnections to the Fire Detection System, the network infrastructure, the loudspeakers and the loudspeaker wiring in accordance with the provisions of the applicable standards and the directions provided in the Bosch PRAESENSA ULLD.				
<b>Visual signaling</b>				Y/N:



<ul style="list-style-type: none"><li>- When strobes are required, an Altronix R1002ULADA - Rack Mountable NAC Power Extender and RE2 - Rack Mount Battery Enclosure can be installed in the same UL-certified rack.</li><li>- When a combination of clear strobes for Fire Alarm and amber strobes for Mass Notification Systems are required, install at least two separate R1002ULADA.</li></ul>	
<b>Physical Access Control level</b>	Y/N:
<ul style="list-style-type: none"><li>- First responder panel: the call stations PRA-CSLD and PRA-CSLW and the call station extension PRA-CSE with Physical Access Control level 0 can only be used for ancillary functionality.</li><li>- For the emergency control of the PRAESENSA system, the first responder panel for USA (PRA-FRP3-US) can be used. The lockable door of this device ensures Physical Access Control level 1.</li><li>- End-of-line board: the end-of-line board PRA-EOL-US must be installed in a UL-listed junction box to ensure Physical Access Control level 1.</li></ul>	
<b>Field connections</b>	Y/N:
Install all field wiring in accordance with the specified circuit class, wiring class and minimum wire gauge, provided in the Bosch PRAESENSA ULLD.	

## 29 DNV-GL type approval

DNV-GL type approval for PRAESENSA systems installed on vessels requires certain installation and configuration directions to be adhered to.

### 29.1 Introduction

The Bosch PRAESENSA system is designed to operate as a PA/GA (Public Address/General Alarm) system, providing emergency announcement functions in accordance with the requirements of international standards, while also providing functions for business announcement and background music.

The PRAESENSA PA/GA system includes system controllers, multi-channel amplifiers, desktop and wall mount emergency call stations, uninterruptable power supplies and network switches.

Installers of the PRAESENSA PA/GA system shall review and understand the architecture and the installation and configuration processes of PRAESENSA in order to build up the system in compliance with DNV-GL type approval requirements. This information is available in the PRAESENSA installation manual, with focus on the hardware, and the PRAESENSA configuration manual, with focus on the software.

### 29.2 Checklist

In this checklist specific issues that require special attention from the installers when installing a PRAESENSA PA/GA system are described. Each section of the checklist must be approved after installation for compliance (Y/N-field).

<b>DNV-GL PA/GA compliance checklist</b>	
<b>System compliance</b>	Y/N:
<p>PRAESENSA is a networked sound system in which all system elements are connected via OMNEO, the secure Bosch network protocol for audio and control on Ethernet. A system comprises several system elements, or devices.</p> <p>The Type Approval Certificate TAA00002RC, issued by DNV-GL, certifies that PRAESENSA is found to comply with:</p> <ul style="list-style-type: none"> <li>– DNV GL rules for classification - Ships, offshore units, and high speed and light craft</li> <li>– IMO Res. A.694(17) General requirements for shipborne radio equipment forming part of the global maritime distress and safety system (GMDSS) and for electronic navigational aids</li> <li>– IMO A.1021(26) Code on alerts and indicators (2009)</li> <li>– LSA Code VII 7.2</li> <li>– IMO MSC/Circ. 808 Recommendation on performance standards for public address systems on passenger ships, including cabling (2017)</li> </ul> <p>Products approved by this certificate are accepted for installation on all vessels classed by DNV-GL.</p> <p>The PRAESENSA Public Address and General Alarm system can be installed as either:</p> <ul style="list-style-type: none"> <li>– PA system only</li> <li>– GA system only</li> <li>– Integrated PA and GA system</li> </ul> <p>The PRAESENSA system may be used on cargo ships, passenger vessels, high-speed and light craft and mobile offshore units for compliance with the following codes/rules/regulations:</p>	

<b>DNV-GL PA/GA compliance checklist</b>	
<ul style="list-style-type: none"> <li>- SOLAS</li> <li>- HSC Code</li> <li>- MODU Code</li> <li>- DNV-GL Statutory Interpretations [July 2015]</li> </ul> <p>PRAESENSA PA/GA installations that are used for GA-functions shall only use products that are listed in the PRAESENSA Type Approval Certificate TAA00002RC. Extension of a PRAESENSA system with non-listed equipment is possible, but if this equipment</p> <ul style="list-style-type: none"> <li>- is directly connected to one of the system devices, or</li> <li>- is network-linked to the system using OMNEO, Dante or AES67 for audio contribution or distribution, or</li> <li>- is network-linked to the system using the PRAESENSA Open Interface, or</li> <li>- is part of the network infrastructure, such as switches, routers and media converters,</li> </ul> <p>then the following restrictions apply to this equipment:</p> <ul style="list-style-type: none"> <li>- it shall not be used to perform GA-functions or transfer data to perform GA-functions, and</li> <li>- it shall be protected against unauthorized access, and</li> <li>- its internet connection shall be provided with the highest level of cybersecurity, and</li> <li>- its Wi-Fi and Bluetooth connections shall be disabled.</li> </ul> <p><b>Note:</b> The OMN-ARNIE, OMN-ARNIS and the CISCO IE-5000-12S12P-10G switch do not have DNV-GL Type Approval. As such, PRAESENSA multi-subnet systems cannot be used for GA-functions.</p>	
<b>Location</b>	Y/N:
<p>The following location requirements for installation must be taken into account:</p> <ul style="list-style-type: none"> <li>- The PRAESENSA equipment can be installed in one of the main area locations on board in accordance with the Class Guideline DNVGL-CG-0339 and the location class of each product, as indicated on the DNV-GL certificate.</li> <li>- Call stations with functions for activation of emergency PA and GA are to be installed in locations with controlled access.</li> <li>- To prevent acoustic feedback ('howling'), do not mount a zone loudspeaker close to a call station when that loudspeaker may receive calls from that call station. Because a PRAESENSA call station has a built-in monitor loudspeaker (that is switched off while the microphone is open) there is also no need for an overhead zone loudspeaker.</li> <li>- The following safe distance to the <i>standard</i> magnetic compass must be considered for the PRA-CSLD, PRA-CSLW and PRA-CSE: &gt; 85 cm (&gt; 34 in).</li> <li>- The following safe distance to the <i>steering</i> magnetic compass must be considered for the PRA-CSLD, PRA-CSLW and PRA-CSE: &gt; 55 cm (&gt; 22 in).</li> <li>- Other PRAESENSA products are not to be positioned in the vicinity of a magnetic compass.</li> </ul>	
<b>Installation</b>	Y/N:
<p>The following installation restrictions apply:</p> <ul style="list-style-type: none"> <li>- When separate PA and GA systems are installed, no single fault tolerance is required as the combination of both systems provides redundancy.</li> </ul>	

### DNV-GL PA/GA compliance checklist

- For a system used for PA on passenger vessels or used for integrated PA and GA on any vessel, essential parts of the system shall be duplicated (A+B systems). Various duplications are possible with PRAESENSA, like system controller redundancy, double network connections, A/B loudspeaker cabling and power supplies with battery backup facilities. Other duplications are already integrated in PRAESENSA, like spare amplifier channels and redundant power converters. Information about duplication of essential parts of a system is available in the PRAESENSA installation manual.
- When used for passenger vessels, the A+B systems are to be installed in separate fire zones.
- When used for cargo vessels, the system may be installed on one location, but it must be installed with single fault tolerance.
- When used for a combined PA/GA system, as a minimum two independent speaker runs A and B are required with interleaved loudspeakers, or the loudspeakers must be connected in closed loop between zone group outputs A and B.
- For ongoing announcements during a switchover from the duty system controller to the backup system controller the following should be taken into account:
  - Automated GA emergency alarm activation should always be done via PRAESENSA control inputs (contact closure) to ensure that the GA emergency alarm continues after switchover. It is not allowed to activate GA emergency alarms from a call station.
  - For manual emergency PA announcements (using the PTT button on a call station or panel), it is accepted that the announcement is terminated after a switchover and must be reinitiated by the user.
  - A call station capable of issuing GA and emergency PA shall be connected to both system controllers (duty and backup). This is automatically achieved by connecting all PRAESENSA devices in the same subnet of the network and configuring both system controllers as a redundant pair.
- The following power management options are allowed:
  - Connection to a mains and emergency source of power are handled by an Uninterruptable Power Supply (UPS) outside the PRAESENSA system.
  - Connection to a mains source of power is handled by PRA-MPS3 devices, that have a battery connected of sufficient capacity.
- Output contacts shall be used to override local muting or local volume controls (at or near the speakers) during a GA and emergency PA announcement. See *Control outputs, page 154* section of this manual.
- Emergency PA shall have a priority higher than GA, otherwise it is not possible to have an emergency PA announcement when GA is already running. General (business) PA should have a priority that is lower than GA and emergency PA.
- Any call station that is not used for emergency PA activation shall have a lower priority than GA.
- Call stations with functions for activation of emergency PA and GA shall be provided with means to avoid unintended use. Each configured button of a PRA-CSE call station extension for such a call station must have a clear descriptive label to identify its function. To protect buttons from being pushed accidentally, a button cap must be mounted on each button that can activate an emergency function. See sections *Labeling, page 204* and *Mounting a button cap, page 206* of this manual.

<b>DNV-GL PA/GA compliance checklist</b>	
<p>– In order to reset a GA emergency alarm as a default single button action, a combined Acknowledge/Reset action must be configured for that button to prevent that two buttons need to be pressed separately. In addition, by selecting Reset aborts active emergency calls for that button, the reset action will not be blocked by emergency calls that are still active.</p>	
<b>Cabling</b>	Y/N:
<p>Cables and wiring serving internal communications or signals should, as far as practicable, be routed clear of galleys, laundries, machinery spaces of category A and their casings, and other high fire risk areas unless serving those spaces.</p> <p>Where possible, all such cables should be run in such a manner so as to preclude that they are being rendered unserviceable by heating of the bulkheads that may be caused by a fire in an adjacent space. All areas of each fire zone should be served by at least two dedicated loudspeaker runs sufficiently separated throughout their length.</p> <p>Using loop wiring with entry into a fire compartment from two different sides, often the use of fire resistant cables can be evaded. But in case fire resistant cables are specified within the system design, these cables are available on the market with DNV-GL Type Approval, for loudspeaker and power cabling, as well as for short distance CAT6A network cabling and for longer distance glass optical fiber cabling.</p>	

## 30 Architects' and engineers' specifications

This chapter provides the architects' and engineers' specifications of the PRAESENSA system and the individual devices.

### 30.1 System

The Public Address and Voice Alarm System shall be fully IP-network based. All system devices such as system controller, amplifiers and call stations shall communicate via IP, using an Audio over IP (AoIP) protocol that supports AES67 for audio and using AES70 for control, with encryption and authentication to prevent unauthorized access, misuse and modification of data. The audio part shall support Layer 3 connections via routers between subnets with latency of less than 10 ms and synchronized outputs. The control data part shall be guaranteed by Transmission Control Protocol (TCP) Layer 4. The system shall support >100 simultaneous channels for music routing and making calls, using an uncompressed, high-resolution digital audio format with 24-bit sample size and 48 kHz sample rate. A system based on a single system controller shall support at least 200 system devices and 500 zones.

System functionality shall be defined in software, allowing for regular updates for functional and/or security improvements. The system software shall run on the system controller with additional firmware on other system devices for device-related functions. Upload and installation of new firmware into the system devices shall be secure. System configuration shall be possible using a standard web browser, connected to the embedded webserver in the system controller, using HTTPS (HTTP Secure) communication. It shall support multiple access levels with associated access rights. After completion of the system configuration, no connection to a PC shall be required for operation. It shall be possible to connect multiple backup system controllers for dual redundancy with automatic fail-over. The system shall support autonomous operation of each backup system controller with its connected devices in case a section gets disconnected from the rest of the system. The system software shall support the discovery and assignment of all system devices in a system and the individual configuration of each device. The system software shall support configurable call definitions for user calls and related actions that can be assigned to virtual and/or real control inputs and call station buttons. A call definition shall define the following: priority, start and end tones with volume setting, an audio input for live speech insertion with volume setting, a message or sequence of messages with a number of repetitions and volume setting, maximum call duration and optional automatic scheduling with duration and interval. The system software shall permit uploading of individual wav-files for messages and tones to the system controller, with integrity supervision of stored wav-files. It shall support zone definition and zone grouping with amplifier channel to zone assignment. The system software shall configure and control all device inputs and outputs in the system, including audio processing functions, operation modes, assigned functions and connections and the supervision thereof. The system shall include diagnosis and logging software, supporting different modes of inquiry, including call events and fault events. It shall be possible to view fault events, collected by the system controller, on a call station screen, including the fault status of connected third party equipment. It shall be possible to acknowledge and reset faults and alarm states, and to log these actions.

The system devices shall be certified for EN 54 / ISO 7240, marked for CE and be compliant with the RoHS directive. Warranty shall be three years minimum. The system shall be a Bosch PRAESENSA system.

## 30.2 System controller (SCL, SCS)

The IP-networked system controller shall be designed exclusively for use with Bosch PRAESENSA systems. The system controller shall dynamically assign network audio channels for audio routing between system devices across multiple subnets. It shall support >100 simultaneous high-resolution audio channels (24-bit, 48 kHz) for music routing and making calls, with encryption and authentication to protect against eavesdropping and hacking. It shall be capable of receiving Dante and AES67 audio streams. A SIP/VoIP telephone interface shall be available. The system controller shall provide an interface for control data and multi-channel digital audio over OMNEO using an integrated 5-port Ethernet switch for redundant network connections, supporting RSTP and loop-through cabling. The system controller shall have dual power supply inputs and power supplies. The system controller shall manage all devices in the system to provide the configured system functions. It shall incorporate a supervised storage for message and tone files with networked playback of up to eight streams simultaneously. It shall keep an internal log of fault events and call events. The system controller shall provide a secure TCP/IP open interface for remote control and diagnostics. The system controller shall provide front-panel LED indications for the status of power supplies and the presence of faults in the system and provide additional software monitoring and fault reporting features. The system controller shall be rack mountable (1U). It shall be possible to connect a backup system controller for dual redundancy with automatic fail-over. The system controller shall be certified for EN 54-16 / ISO 7240-16, marked for CE and be compliant with the RoHS directive. Warranty shall be three years minimum. If the system size permits, the system controller shall be a Bosch PRA-SCS, otherwise a Bosch PRA-SCL.

## 30.3 Amplifier, 600W 4-channel (AD604)

### Architects' and engineers' specifications

The IP-networked 4-channel amplifier shall be designed exclusively for use with Bosch PRAESENSA systems. The amplifier shall adapt the maximum output power of each amplifier channel to its connected loudspeaker load, with free assignable output power per channel for a total maximum of 600 watt per amplifier, supporting 70 V or 100 V operation with direct drive capability and outputs that are galvanically insulated from ground. The amplifier shall have a built-in independent spare amplifier channel for automatic failover. The amplifier shall provide an interface for control data and multi-channel digital audio over OMNEO using dual Ethernet ports for redundant network connection, supporting RSTP and loop-through cabling, with automatic failover to an analog lifeline input. The amplifier shall have dual power supply inputs and power supplies. All amplifier channels shall have independent A/B zone outputs with support for class-A loudspeaker loops. All amplifier channels shall supervise the integrity of connected loudspeaker lines without interruption of audio distribution. The amplifier shall provide front-panel LED status indications for the network link, ground fault, power supplies and audio channels, and provide additional software monitoring and fault reporting features. The amplifier shall be rack mountable (1U) and feature software-configurable signal processing including level control, parametric equalization, limiting and delay for each channel. The amplifier shall be certified for EN 54-16 / ISO 7240-16, marked for CE and be compliant with the RoHS directive. Warranty shall be three years minimum. The amplifier shall be a Bosch PRA-AD604.

## 30.4 Amplifier, 600W 8-channel (AD608)

### Architects' and engineers' specifications

The IP-networked 8-channel amplifier shall be designed exclusively for use with Bosch PRAESENSA systems. The amplifier shall adapt the maximum output power of each amplifier channel to its connected loudspeaker load, with free assignable output power per channel for a total maximum of 600 watt per amplifier, supporting 70 V or 100 V operation with direct drive capability and outputs that are galvanically insulated from ground. The amplifier shall have a built-in independent spare amplifier channel for automatic failover. The amplifier shall provide an interface for control data and multi-channel digital audio over OMNEO using dual Ethernet ports for redundant network connection, supporting RSTP and loop-through cabling, with automatic failover to an analog lifeline input. The amplifier shall have dual power supply inputs and power supplies. All amplifier channels shall have independent A/B zone outputs with support for class-A loudspeaker loops. All amplifier channels shall supervise the integrity of connected loudspeaker lines without interruption of audio distribution. The amplifier shall provide front-panel LED status indications for the network link, ground fault, power supplies and audio channels, and provide additional software monitoring and fault reporting features. The amplifier shall be rack mountable (1U) and feature software-configurable signal processing including level control, parametric equalization, limiting and delay for each channel. The amplifier shall be certified for EN 54-16 / ISO 7240-16, marked for CE and be compliant with the RoHS directive. Warranty shall be three years minimum. The amplifier shall be a Bosch PRA-AD608.

## 30.5 End-of-line device (EOL)

### Architects' and engineers' specifications

The end-of-line device shall be designed exclusively for use with Bosch PRAESENSA systems. The end-of-line device shall only require a connection with the end of the loudspeaker line to supervise its integrity. Supervision reliability shall not depend on the number of connected loudspeakers. Supervision shall be inaudible and not interrupt audio content. The end-of-line device shall be certified for EN 54-16 / ISO 7240-16, marked for CE and be compliant with the RoHS directive. Warranty shall be three years minimum. The end-of-line device shall be a Bosch PRA-EOL.

## 30.6 Multifunction power supply, large (MPS3)

### Architects' and engineers' specifications

The IP-networked multifunction power supply shall be designed exclusively for use with Bosch PRAESENSA systems. The multifunction power supply shall contain four independent mains power supplies with power factor correction and dual output connection facilities to power up to three 600 W amplifiers and to power a system controller and two call stations. The multifunction power supply shall have an integrated battery charger for a connected battery, and independent converters to use the battery as a backup power source for all connected loads in case of mains failures. Failover to the backup battery shall be without interruption of output power. It shall use a single 12 V VRLA backup battery to eliminate the need for battery balancing, while maximizing battery lifetime and power density. The multifunction power supply shall have eight general purpose control inputs with connection supervision and eight voltage free control outputs. The multifunction power supply shall provide an interface for control data and to receive a backup audio channel over OMNEO using an integrated 6-port Ethernet switch for redundant network connections, supporting RSTP and loop-through cabling. Two ports shall have PoE to provide redundant power to a call station. The backup audio channel shall be available as analog lifeline to connected



amplifiers. The multifunction power supply shall provide front-panel LED indications for status of the power supply sections, mains and battery, network link and fault presence, and provide additional software monitoring and fault reporting features. The multifunction power supply shall be rack mountable (2U). The multifunction power supply shall be certified for EN 54-4 / ISO 7240-4, marked for CE and be compliant with the RoHS directive. Warranty shall be three years minimum. The multifunction power supply shall be a Bosch PRA-MPS3.

### 30.7 **Ambient noise sensor (ANS)**

The IP-networked ambient noise sensor shall be designed exclusively for use with Bosch PRAESENSA systems. It shall provide an interface for control data over OMNEO using Ethernet. It shall receive Power over Ethernet (PoE) via its network connection. The ambient noise sensor shall have an integrated DSP for software configurable frequency response adjustments to optimize tracking of disturbing noise signals and/or to minimize the influence of non-disturbing out-of-band signals. It shall be IP65 classified for solid particle and liquid ingress protection. The ambient noise sensor shall be certified for EN 54-16 and ISO 7240-16, marked for CE and be compliant with the RoHS directive. Warranty shall be three years minimum. The ambient noise sensor shall be a Bosch PRA-ANS.

### 30.8 **Control interface module (IM16C8)**

The IP-networked control interface module shall be designed exclusively for use with Bosch PRAESENSA systems. The module shall provide an interface to receive control actions from external switches and to trigger external control circuits. The control data communication shall use OMNEO with dual Ethernet ports for redundant network connection, supporting RSTP and loop-through cabling. It shall be capable of receiving Power over Ethernet (PoE) through either one or both network connections. The DIN rail housing provides removable terminal blocks to connect 16 configurable general-purpose control inputs with connection supervision, 8 voltage-free, single-pole double-throw (SPDT) relay contacts and 2 trigger outputs for NAC boosters with reverse polarity connection supervision. The control interface module shall be certified for EN 54-16 and ISO 7240-16, marked for CE and be compliant with the RoHS directive. The warranty shall be three years minimum. The control interface module shall be a Bosch PRA-IM16C8.

### 30.9 **LCD call station (CSLD, CSLW)**

#### **PRA-CSLD**

The IP-networked desktop call station shall be designed exclusively for use with Bosch PRAESENSA systems. The desktop call station shall provide an interface for control data and multi-channel digital audio over OMNEO using dual Ethernet ports for redundant network connection, supporting RSTP and loop-through cabling. It shall receive Power over Ethernet (PoE) via either one or both network connections. The desktop call station shall provide a backlit full-color capacitive touch panel LCD as user interface for business and evacuation purposes. The desktop call station shall accept up to four optional extensions, each offering 12 configurable buttons for zone selection and other purposes. It shall provide control and routing of live speech calls, stored messages and music with volume control per zone. Authentication on the LCD with user number and PIN code shall protect the device against unauthorized access. The desktop call station shall have a gooseneck cardioid microphone for live calls and a 3.5 mm jack line level input for background music, and provide software-configurable signal processing including sensitivity control, parametric equalization

and limiting. The desktop call station shall be certified for EN 54-16 / ISO 7240-16, marked for CE and be compliant with the RoHS directive. Warranty shall be three years minimum. The desktop call station shall be a Bosch PRA-CSLD.

#### **PRA-CSLW**

The IP-networked wallmount call station shall be designed exclusively for use with Bosch PRAESENSA systems. The wallmount call station shall provide an interface for control data and multi-channel digital audio over OMNEO using dual Ethernet ports for redundant network connection, supporting RSTP and loop-through cabling. It shall receive Power over Ethernet (PoE) via either one or both network connections. The wallmount call station shall provide a backlit full-color capacitive touch panel LCD as user interface for business and evacuation purposes. The wallmount call station shall accept up to four optional call station extensions, each offering 12 configurable buttons for zone selection and other purposes. It shall provide control and routing of live speech calls, stored messages and music with volume control per zone. Authentication on the LCD with user number and PIN code shall protect the device against unauthorized access. The wallmount call station shall have an omnidirectional fist microphone for live calls and a 3.5 mm jack line level input for background music, and provide software-configurable signal processing including sensitivity control, parametric equalization and limiting. The wallmount call station shall be certified for EN 54-16 / ISO 7240-16, marked for CE and be compliant with the RoHS directive. Warranty shall be three years minimum. The wallmount call station shall be a Bosch PRA-CSLW.

### **30.10 Call station extension (CSE)**

#### **Architects' and engineers' specifications**

The call station extension shall be designed exclusively for use with Bosch PRAESENSA systems. The call station extension shall offer electrical and mechanical connection facilities for use with a desktop or wallmount call station. It shall provide 12 configurable buttons for zone selection and other purposes. Each button has tactile feedback and a light ring activation indicator, complemented with a set of multi-color LEDs for function related status indications. The call station extension shall have a removable front cover to put language independent button labels behind the front cover. The call station extension shall be certified for EN 54-16 / ISO 7240-16, marked for CE and be compliant with the RoHS directive. Warranty shall be three years minimum. The call station extension shall be a Bosch PRA-CSE.

### **30.11 Call station kit (CSBK)**

The IP-networked call station kit shall be designed exclusively for use with Bosch PRAESENSA systems. The call station kit shall provide an interface for control data and multi-channel digital audio over OMNEO using dual Ethernet ports for redundant network connection, supporting RSTP and loop-through cabling. It shall receive Power over Ethernet (PoE) via either one or both network connections. The call station kit shall have a CAN-bus to interface with call station extensions or a custom built user interface panel for zone selection and other purposes. It shall provide control and routing of live speech calls, stored messages and music with volume control per zone. The call station kit shall have a detachable, omnidirectional fist microphone for live calls and a 3.5 mm jack line level input for background music, and provide software-configurable signal processing including sensitivity control, parametric equalization and limiting. The call station kit shall be marked for CE, and be compliant with the RoHS directive. Warranty shall be three years minimum. The call station kit shall be a Bosch PRA-CSBK.

## 30.12 Call station extension kit (CSEK)

The call station extension kit shall be designed exclusively for use with Bosch PRAESENSA systems. In cooperation with the basic call station kit, the call station extension kit shall offer connection facilities for up to 24 configurable switches with associated selection and status indicators for zone selection and other purposes.

The call station extension kit shall have a CAN-bus interface for communication with the basic call station kit, with a loop-through connection to facilitate a subsequent call station kit. The call station extension kit shall be marked for CE and be compliant with the RoHS directive. Warranty shall be three years minimum. The call station extension shall be a Bosch PRA-CSEK.

## 30.13 Wall control panel (WCP-EU, WCP-US)

The IP networked wall control panel shall be designed exclusively for use with Bosch PRAESENSA systems. It shall provide an interface for control data over OMNEO using Ethernet. It shall receive Power over Ethernet (PoE) through its network connection. It shall fit in a standard electrical back box for flush-mount installations. The wall control panel shall be an interface to the sound system to select a background music channel in a zone and change its volume level. It shall have a single push/rotate knob and a full color LCD with backlight for easy navigation and clear indication of the operating zone, selected channel and actual volume level. It shall be fit for operation by untrained people, but it shall also have configurable PIN-code access to restrict access to authorized staff. The wall control panel shall be marked for CE and be compliant with the RoHS directive. Warranty shall be three years minimum. The wall control panel shall be a Bosch PRA-WCP-EU or PRA-WCP-US.

## 30.14 Public address server (APAS)

The advanced public address server shall be an industrial PC acting as a server for the public address system, to add advanced business related public address functions, using connected operator devices. Its pre-installed and licensed software shall allow connected operator devices to control announcements and background music in selected zones, streaming from its own internal memory or from external music portals and Internet radio stations. It shall offer announcement creation and control facilities to the operator to address selected zones, including message scheduling, live call recording with pre-monitoring and playback, and multi-lingual text-to-speech calls, using on-line conversion services. For security reasons the server shall have two Ethernet ports to connect the device to two different local area networks, one secure network for the public address system, and one corporate network with access to the operator devices and the Internet. It shall have an integrated web server to allow operator devices to be platform independent and use a browser to access the server. The server shall be able to stream up to 10 high quality audio channels into the public address system, using the AES67 protocol. The server shall be marked for UL and CE and be compliant with the RoHS directive. Warranty shall be three years minimum. It shall be optimized for use with a Bosch PRAESENSA system for public address purposes. The advanced public address server shall be a Bosch PRA-APAS.

## 30.15 Public address license (APAL)

The advanced public address license is a code for a single operator device to connect to and access an advanced public address server. It shall be possible to use a PC or wireless tablet as operator device and use multiple operator devices in parallel, requiring as many licenses. Upon connection, each operator device shall be able to control parts of the public address

system, using a browser on the device as a graphical user interface, controlled by mouse or touch screen. The graphic user interface shall be optimized for use with a 10" touch screen. The license code shall allow the operator device to have several unique operator profiles on that device, with tailored functionalities for each user. It shall offer easy zone selection for voice announcements, control of background music sources and volume in selected zones, the ability to make live call recordings of announcements with pre-monitoring and playback to selected zones, the ability to do live and scheduled playback of stored messages, and playback of text based announcements with automatic (multi-lingual) online text-to-speech conversion. The advanced public address license shall be used with the Bosch PRAESENSA advanced public address server, PRA-APAS. The advanced public address license shall be a Bosch PRA-APAL.

### **30.16 Ethernet switch (ES8P2S)**

The Ethernet switch shall be a managed 10-port Gigabit switch with eight ports providing PoE and two ports providing SFP sockets for glass fiber transceivers. The switch shall have dual redundant, wide range DC power supply inputs for 24 to 48 V. It shall supervise its DC power supply inputs and port links, and have a fault relay output for fault reporting. The Ethernet switch shall be DIN rail mountable with convection cooling. It shall be certified for EN 54-16 in combination with Bosch PRAESENSA systems for public address and voice alarm purposes. The switch shall be marked for UL and CE and be compliant with the RoHS directive. Warranty shall be three years minimum. The Ethernet switch shall be a Bosch PRA-ES8P2S.

### **30.17 Fiber transceiver (SFPLX, SFPSX)**

The LX fiber transceiver shall be a wide temperature Small Form-factor Pluggable (SFP) for use with single-mode fiber and IR light with a wavelength of 1310 nm, to cover glass fiber link lengths of up to 10 km. It shall be certified for EN 54-16 in combination with Bosch PRAESENSA systems for public address and voice alarm purposes. The transceiver shall be marked for UL and CE and be compliant with the RoHS directive. Warranty shall be three years minimum. The LX-transceiver shall be a Bosch PRA-SFPLX.

The SX fiber transceiver shall be a wide temperature Small Form-factor Pluggable (SFP) for use with multi-mode fiber and IR light with a wavelength of 850 nm, to cover glass fiber link lengths of up to 550 m. It shall be certified for EN 54-16 in combination with Bosch PRAESENSA systems for public address and voice alarm purposes. The transceiver shall be marked for UL and CE and be compliant with the RoHS directive. Warranty shall be three years minimum. The SX-transceiver shall be a Bosch PRA-SFPSX.

### **30.18 Power supply module (PSM24, PSM48)**

The 24 V power supply module shall contain a mains input with power factor correction and a 24 V output. Output current capability shall be 10 A continuous and 15 A peak. It shall be approved to power Bosch PRAESENSA and PAVIRO equipment. The power supply shall be DIN-rail mountable with passive cooling. The power supply shall be marked for UL and CE and be compliant with the RoHS directive. Warranty shall be three years minimum. The power supply module shall be a Bosch PRA-PSM24.

The 48 V power supply module shall contain a mains input with power factor correction and a 48 V output. Output current capability shall be 5 A continuous and 7.5 A peak. It shall be approved to power one 600 W Bosch PRAESENSA amplifier. The power supply shall be

DIN-rail mountable with convection cooling. The power supply shall be marked for UL and CE and be compliant with the RoHS directive. Warranty shall be three years minimum. The power supply module shall be a Bosch PRA-PSM48.

## 30.19

### **License for subsystem PRAESENSA (LSPRA)**

The license for subsystem PRAESENSA shall allow a master controller to manage several subsystem controllers. It shall be possible to connect up to 20 system controllers in a large network to support up to 3000 devices and 10,000 zones. There shall be one master controller. The master controller shall require one active license per networked subsystem controller. It shall be possible to have a standby master controller for redundancy. Each subsystem shall also have the option to provide controller redundancy. It shall be possible to configure an EN 54-16 compliant fireman's microphone. Upon connection, across the multiple subsystems, the fireman's microphone shall be able to perform live announcement with evacuation priority, start and stop emergency messages, indicate zone status, and reports system wide faults according to EN 54-16. It shall be possible to acknowledge and reset system wide faults from a single location. It shall be possible to make system wide business calls and start and stop business messages. BGM sources shall be available across the system while the volume shall be controlled in each system individually. The license for subsystem shall be used with the Bosch PRAESENSA system controller, PRA-SCL. The license for subsystem PRAESENSA shall be a Bosch PRA-LSPRA.

## 31 Tones

PRAESENSA has a library of attention tones, alarm tones and test tones, formatted as wav-files. These tones have an RMS level at or below -9 dBFS to stay within the power limits of the PRAESENSA amplifiers with maximum loudspeaker load.

Refer to *Amplifier power and crest factor*, page 54 for background information.

With the release of PRAESENSA V1.80 the tone set is updated with new tones and the basic tone files are shorter compared to earlier releases. Because PRAESENSA supports gapless playback of repeating tones and messages, the tones have a shorter length to keep the sound files small and to reduce the minimum duration. Make continuous tones by repeating a tone infinitely. Configure this in the **Call definition** page of the configuration software. The tones are designed for smooth repetitions without clicks or gaps. Modify tones with free software programs like Audacity. For instance, you can combine tones with announcements or make them longer by repeating a section multiple times in the same file.

Requests for other tones can be directed to Bosch Security Systems, Eindhoven, The Netherlands.

### Refer to

- *Amplifier power and crest factor*, page 54

### 31.1 Alarm tones

#### Tone characteristics

- Mono, sample rate 48 kHz, 16-bit sample depth.
- Peak level: < -1.3 dBFS (full scale square wave = 0 dBFS).
- RMS level: < -9 dBFS (full scale sine wave = -3 dBFS).
- Glitch-free and gapless repeat.
- MS = Multi-sine, TS = Triple-sine, SW = Sine wave, B = Bell.
- Filename format: Alarm\_MS\_<frequency (range)>\_<duty cycle>\_<duration>.wav.

#### Alarm\_B\_100p\_1s

- Bell sound, 1 s
- Duty cycle 100%
- Offshore “Abandon platform”

#### Alarm\_B\_100p\_2.5s

- Bell sound with release, 2.5 s
- Duty cycle 100%
- Offshore “FG”

#### Alarm\_MS\_300-1200Hz\_100p\_1s.wav

- Sweep 300 Hz - 1200 Hz, up in 1 s
- Duty cycle 100%
- “General purpose”

#### Alarm\_MS\_350-500Hz\_100p\_1s.wav

- Sweep 350 Hz - 500 Hz, up in 1 s
- Duty cycle 100%

#### Alarm\_MS\_400Hz\_100p\_1s.wav

- Continuous 400 Hz, 1 s
- Duty cycle 100%

#### Alarm\_MS\_420Hz\_48p\_(0.60+0.65)s.wav

- Intermittent 420 Hz, 0.60 s on, 0.65 s off

- Duty cycle 48%
- Australia, AS 2220 "Alert" (extended spectrum)
- Alarm\_MS\_420Hz\_50p\_(0.6+0.6)s.wav**
- Intermittent 420 Hz, 0.6 s on, 0.6 s off
- Duty cycle 50%
- Australia, AS 1670.4, ISO 7731 "Alert" (extended spectrum)
- Alarm\_MS\_422-775Hz\_46p\_(0.85+1.00)s.wav**
- Sweep 422 Hz - 775 Hz, up in 0.85 s, 1.0 s off
- Duty cycle 46%
- USA, "NFPA Whoop"
- Alarm\_MS\_500-1200-500Hz\_100p\_(1.5+1.5)s.wav**
- Sweep 500 Hz - 1200 Hz, up in 1.5 s, down in 1.5 s
- Duty cycle 100%
- "Siren"
- Alarm\_MS\_500-1200Hz\_94p\_(3.75+0.25)s.wav**
- Sweep 500 Hz - 1200 Hz, up in 3.75 s, 0.25 s off
- Duty cycle 94%
- Australia, AS 2220 -1978 "Action"
- Alarm\_MS\_500-1200Hz\_88p\_(3.5+0.5)s.wav**
- Sweep 500 Hz - 1200 Hz, up in 3.5 s, 0.5 s off
- Duty cycle 88%
- Netherlands, NEN 2575 "Evacuation"
- Alarm\_MS\_500Hz\_20p\_(0.15+0.60)s.wav**
- Intermittent 500 Hz, 0.15 s on, 0.6 s off
- Duty cycle 20%
- Sweden, SS 03 17 11 "Local Warning"
- Alarm\_MS\_500Hz\_60p\_4x(0.15+0.10)s.wav**
- Intermittent 500 Hz, 0.15 s on, 0.1 s off, 4 repetitions
- Duty cycle 60%
- Sweden, SS 03 17 11 "Imminent Danger"
- Alarm\_MS\_500Hz\_100p\_1s.wav**
- Continuous 500 Hz, 1 s
- Duty cycle 100%
- Sweden, SS 03 17 11 "All clear"; Germany, KTA3901 "All clear"
- Alarm\_MS\_520Hz\_13p\_(0.5+3.5)s.wav**
- Intermittent 520 Hz, 0.5 s on, 3.5 s off
- Duty cycle 13%
- Australia, AS 4428.16 "Alert" (extended spectrum)
- Alarm\_MS\_520Hz\_38p\_3x(0.5+0.5)s+1s.wav**
- Intermittent 520 Hz, 0.5 s on, 0.5 s off, 0.5 s on, 0.5 s off, 0.5 s on, 1.5 s off
- Duty cycle 38%
- Australia, AS 4428.16, ISO 8201 "Evacuation" (extended spectrum)
- Alarm\_MS\_550+440Hz\_100p\_(1+1)s.wav**
- Alternating 550 Hz, 1 s and 440 Hz, 1 s
- Duty cycle 100%
- Sweden "Turn Out"
- Alarm\_MS\_560+440Hz\_100p\_2x(0.1+0.4)s.wav**
- Alternating 560 Hz, 0.1 s and 440 Hz, 0.4 s, 2 repetitions
- Duty cycle 100%

- France, NF S 32-001 "Fire"

**Alarm\_MS\_660Hz\_33p\_(6.5+13)s.wav**

- Intermittent 660 Hz, 6.5 s on, 13 s off
- Duty cycle 33%
- Sweden "Pre-mess"

**Alarm\_MS\_660Hz\_50p\_(1.8+1.8)s.wav**

- Intermittent 660 Hz, 1.8 s on, 1.8 s off
- Duty cycle 50%
- Sweden "Local warning"

**Alarm\_MS\_660Hz\_50p\_4x(0.15+0.15)s.wav**

- Intermittent 660 Hz, 0.15 s on, 0.15 s off, 4 repetitions
- Duty cycle 50%
- Sweden "Air raid"

**Alarm\_MS\_660Hz\_100p\_1s.wav**

- Continuous 660 Hz, 1 s
- Duty cycle 100 %
- Sweden "All clear"

**Alarm\_MS\_720Hz\_70p\_(0.7+0.3)s.wav**

- Intermittent 720Hz, 0.7 s on, 0.3 s off
- Duty cycle 70%
- Germany "Industrial alarm"

**Alarm\_MS\_800+970Hz\_100p\_2x(0.25+0.25)s.wav**

- Alternating 800 Hz, 0.25 s and 970 Hz, 0.25 s, 2 repetitions
- Duty cycle 100%
- UK, BS 5839-1 "Fire", EN 54-3

**Alarm\_MS\_800-970Hz\_38p\_3x(0.5+0.5)s+1s.wav**

- Sweep 800 Hz - 970 Hz, up in 0.5 s, 0.5 s off, up in 0.5 s, 0.5 s off, up in 0.5 s, 1.5 s off
- Duty cycle 38%
- ISO 8201

**Alarm\_MS\_800-970Hz\_100p\_1s.wav**

- Sweep 800 Hz - 970 Hz, up in 1 s
- Duty cycle 100%
- UK, BS 5839-1 "Fire"

**Alarm\_MS\_800-970Hz\_100p\_7x0.14s.wav**

- Sweep 800 Hz - 970 Hz, up in 0.14 s, 7 repetitions
- Duty cycle 100%
- UK, BS 5839-1 "Fire"

**Alarm\_MS\_970+630Hz\_100p\_(0.5+0.5)s.wav**

- Alternating 970 Hz, 0.5 s and 630 Hz, 0.5 s
- Duty cycle 100%
- UK, BS 5839-1

**Alarm\_MS\_970Hz\_20p\_(0.25+1.00)s.wav**

- Intermittent 970 Hz, 0.25 s on, 1 s off
- Duty cycle 20%
- "General purpose"

**Alarm\_MS\_970Hz\_38p\_3x(0.5+0.5)s+1s.wav**

- Intermittent 970 Hz, 0.5 s on, 0.5 s off, 0.5 s on, 0.5 s off, 0.5 s on, 1.5 s off
- Duty cycle 38%
- ISO 8201 "Emergency evacuation"



**Alarm\_MS\_970Hz\_40p\_5x(1+1)s+(3+7)s.wav**

- Intermittent 970 Hz, 1 s on, 1 s off, 5 repetitions, 3 s on, 7 s off
- Duty cycle 40%
- Maritime

**Alarm\_MS\_970Hz\_50p\_(1+1)s.wav**

- Intermittent 970 Hz, 1 s on, 1 s off
- Duty cycle 50%
- UK, BS 5839-1 "Alert", PFEER "Alert", Maritime

**Alarm\_MS\_970Hz\_50p\_(12+12)s.wav**

- Intermittent 970 Hz, 12 s on, 12 s off
- Duty cycle 50%
- Maritime

**Alarm\_MS\_970Hz\_52p\_7x(1+1)s+(5+4)s.wav**

- Intermittent 970 Hz, 1 s on, 1 s off, 7 repetitions, 5 s on, 4 s off
- Duty cycle 52%
- Maritime "General emergency alarm"

**Alarm\_MS\_970Hz\_56p\_7x(1+1)s+(7+4)s.wav**

- Intermittent 970 Hz, 1 s on, 1 s off, 7 repetitions, 7 s on, 4 s off
- Duty cycle 56%
- Maritime "General emergency alarm"

**Alarm\_MS\_970Hz\_64p\_7x(1+1)s+(7+1)s.wav**

- Intermittent 970 Hz, 1 s on, 1 s off, 7 repetitions, 7 s on, 1 s off
- Duty cycle 64%
- Maritime "General emergency alarm"

**Alarm\_MS\_970Hz\_65p\_(5+1)s+(1+1)s+(5+4)s.wav**

- Intermittent 970 Hz, 5 s on, 1 s off, 1 s on, 1 s off, 5 s on, 4 s off
- Duty cycle 65%
- Maritime

**Alarm\_MS\_970Hz\_67p\_(1+1)s+(3+1)s.wav**

- Intermittent 970 Hz, 1 s on, 1 s off, 3 s on, 1 s off
- Duty cycle 67%
- Maritime IMO "Leave ship"

**Alarm\_MS\_970Hz\_72p\_3x(7+2)s+2s.wav**

- Intermittent 970 Hz, 7 s on, 2 s off, 3 repetitions, 2 s off
- Duty cycle 72%
- Maritime "Man overboard"

**Alarm\_MS\_970Hz\_74p\_4x(5+1)s+3s.wav**

- Intermittent 970 Hz, 5 s on, 1 s off, 4 repetitions, 3 s off
- Duty cycle 74%
- Maritime

**Alarm\_MS\_970Hz\_80p\_(12+3)s.wav**

- Intermittent 970 Hz, 12 s on, 3 s off
- Duty cycle 80%
- Maritime

**Alarm\_MS\_970Hz\_100p\_1s.wav**

- Continuous 970 Hz, 1 s
- Duty cycle 100%
- UK, BS 5839-1 "Evacuate", PFEER "Toxic gas", Maritime "Fire", EN 54-3

**Alarm\_MS\_1000+2000Hz\_100p\_(0.5+0.5)s.wav**

- Alternating 1000 Hz, 0.5 s and 2000 Hz, 0.5 s
- Duty cycle 100%
- Singapore
- Alarm\_MS\_1200-500Hz\_100p\_1s.wav**
- Sweep 1200 Hz - 500 Hz, down in 1 s
- Duty cycle 100%
- Germany, DIN 33404 Part 3, PFEER “Prepare for evacuation”, EN 54-3
- Alarm\_MS\_1400-1600-1400Hz\_100p\_(1.0+0.5)s.wav**
- Sweep 1400 Hz - 1600 Hz, up in 1.0 s, down in 0.5 s
- Duty cycle 100%
- France, NFC 48-265
- Alarm\_MS\_2850Hz\_25p\_3x(0.5+0.5)s+1s.wav**
- Intermittent 2850 Hz, 0.5 s on, 0.5 s off, 0.5 s on, 0.5 s off, 0.5 s on, 1.5 s off
- Duty cycle 25%
- USA, ISO 8201 “High tone”
- Alarm\_SW\_650-1100-650Hz\_50p\_4x(0.125+0.125)s.wav**
- Sweep 650 Hz - 1100 Hz, up and down in 0.125 s, 0.125 s off, 4 repetitions
- Duty cycle 50%
- Offshore “H2S alarm”
- Alarm\_TS\_420Hz\_50p\_(0.6+0.6)s.wav**
- Intermittent 420 Hz, 0.6 s on, 0.6 s off
- Duty cycle 50%
- Australia, AS 1670.4, ISO 7731 “Alert” (standard spectrum)
- Alarm\_TS\_520Hz\_13p\_(0.5+3.5)s.wav**
- Intermittent 520 Hz, 0.5 s on, 3.5 s off
- Duty cycle 13%
- Australia, AS 4428.16 “Alert” (standard spectrum)
- Alarm\_TS\_520Hz\_38p\_3x(0.5+0.5)s+1s.wav**
- Intermittent 520 Hz, 0.5 s on, 0.5 s off, 0.5 s on, 0.5 s off, 0.5 s on, 1.5 s off
- Duty cycle 38%
- Australia, AS 4428.16, ISO 8201 “Evacuation” (standard spectrum)

## 31.2

### Attention tones

#### Tone characteristics

- Mono, sample rate 48 kHz, 16-bit sample depth.
- Filename format: Attention\_<sequence number>\_<number of tones>\_<duration>.wav

#### Attention\_A\_1T\_1.5s.wav

- Single tone chime
- Marimba and Vibraphone, A4
- Peak level -6 dBFS, RMS level < -10 dBFS, 1.5 s

#### Attention\_B\_1T\_1.5s.wav

- Single tone chime
- Marimba and Vibraphone, C#5
- Peak level -6 dBFS, RMS level < -10 dBFS, 1.5 s

#### Attention\_C\_1T\_1.5s.wav

- Single tone chime
- Marimba and Vibraphone, E5
- Peak level -6 dBFS, RMS level < -10 dBFS, 1.5 s

**Attention\_D\_1T\_1.5s.wav**

- Single tone chime
- Marimba and Vibraphone, G5
- Peak level -6 dBFS, RMS level < -10 dBFS, 1.5 s

**Attention\_E1\_2T\_2s.wav**

- Two tone pre-chime
- Marimba and Vibraphone, A4/C#5
- Peak level -6 dBFS, RMS level < -10 dBFS, 2 s

**Attention\_E2\_2T\_2s.wav**

- Two tone post-chime
- Marimba and Vibraphone, C#5/A4
- Peak level -6 dBFS, RMS level < -10 dBFS, 2 s

**Attention\_F1\_3T\_2s.wav**

- Three tone pre-chime
- Marimba and Vibraphone, G4/C5/E5
- Peak level -6 dBFS, RMS level < -10 dBFS, 2 s

**Attention\_F2\_3T\_2s.wav**

- Three tone post-chime
- Marimba and Vibraphone, E5/C5/G4
- Peak level -6 dBFS, RMS level < -10 dBFS, 2 s

**Attention\_G1\_3T\_2.5s.wav**

- Three tone pre-chime
- Marimba and Vibraphone, A#4/D5/F5
- Peak level -6 dBFS, RMS level < -10 dBFS, 2.5 s

**Attention\_G2\_3T\_2.5s.wav**

- Three tone post-chime
- Marimba and Vibraphone, F5/D5/A#4
- Peak level -6 dBFS, RMS level < -10 dBFS, 2.5 s

**Attention\_H1\_4T\_3s.wav**

- Four tone pre-chime
- Marimba and Vibraphone, E5/C5/D5/E4
- Peak level -6 dBFS, RMS level < -10 dBFS, 3 s

**Attention\_H2\_4T\_3s.wav**

- Four tone post-chime
- Marimba and Vibraphone, G4/D5/E5/C5
- Peak level -6 dBFS, RMS level < -10 dBFS, 3 s

**Attention\_J1\_4T\_3s.wav**

- Four tone pre-chime
- Marimba and Vibraphone, G4/C5/E5/G5
- Peak level -6 dBFS, RMS level < -10 dBFS, 3 s

**Attention\_J2\_4T\_3s.wav**

- Four tone post-chime
- Marimba and Vibraphone, G5/E5/C5/G4
- Peak level -6 dBFS, RMS level < -10 dBFS, 3 s

**Attention\_K1\_4T\_2.5s.wav**

- Four tone pre-chime
- Marimba and Vibraphone, G4/C5/E5/G5
- Peak level -6 dBFS, RMS level < -10 dBFS, 2.5 s

**Attention\_K2\_4T\_2.5s.wav**

- Four tone post-chime
- Marimba and Vibraphone, G5/E5/C5/G4
- Peak level -6 dBFS, RMS level < -10 dBFS, 2.5 s

**Attention\_L1\_4T\_3s.wav**

- Four tone pre-chime
- Marimba and Vibraphone, C5/E5/G5/A5
- Peak level -6 dBFS, RMS level < -10 dBFS, 3 s

**Attention\_L2\_4T\_3s.wav**

- Four tone post-chime
- Marimba and Vibraphone, A5/G5/E5/C5
- Peak level -6 dBFS, RMS level < -10 dBFS, 3 s

**Attention\_M1\_6T\_2s.wav**

- Six tone pre-chime
- Marimba and Vibraphone, G4/C5/E5/G4/C5/E5
- Peak level -6 dBFS, RMS level < -10 dBFS, 2 s

**Attention\_M2\_4T\_2s.wav**

- Four tone post-chime
- Marimba and Vibraphone, C5/E5/C5/G4
- Peak level -6 dBFS, RMS level < -10 dBFS, 2 s

**Attention\_N1\_7T\_2s.wav**

- Seven tone pre-chime
- Marimba and Vibraphone, E5/F4/C5/G4/E6/C6/G5
- Peak level -6 dBFS, RMS level < -10 dBFS, 2 s

**Attention\_N2\_4T\_2s.wav**

- Four tone post-chime
- Marimba and Vibraphone, C6/E5/C5/G4
- Peak level -6 dBFS, RMS level < -10 dBFS, 2 s

**Attention\_O1\_6T\_3s.wav**

- Six tone pre-chime
- Marimba and Vibraphone, F5/C5/C5/G5/(A4+C6)/(F4+A5)
- Peak level -6 dBFS, RMS level < -10 dBFS, 3 s

**Attention\_O2\_5T\_2.5s.wav**

- Five tone post-chime
- Marimba and Vibraphone, A#5/A#5/A5/A5/(F4+F5)
- Peak level -6 dBFS, RMS level < -10 dBFS, 2.5 s

**Attention\_P1\_8T\_4s.wav**

- Eight tone pre-chime
- Marimba and Vibraphone, A4/A4/A4/C5/D5/D5/D5/(D4+A4)
- Peak level -6 dBFS, RMS level < -10 dBFS, 4 s

**Attention\_P2\_4T\_2.5s.wav**

- Four tone post-chime
- Marimba and Vibraphone, (A4+D5)/A4/D5/(A4+D5)
- Peak level -6 dBFS, RMS level < -10 dBFS, 2.5 s

**Attention\_Q1\_3T\_3.5s.wav**

- Three tone pre-chime
- Celesta, G4/C5/E5
- Peak level -6 dBFS, RMS level < -10 dBFS, 3.5 s

**Attention\_Q2\_3T\_3.5s.wav**

- Three tone post-chime

- Celesta, E5/C5/G4
- Peak level -6 dBFS, RMS level < -10 dBFS, 3.5 s

#### **Attention\_R\_6T\_2.5s.wav**

- Six tone chime
- Guitar, F4/C5/F5/F4/C5/F5
- Peak level -6 dBFS, RMS level < -10 dBFS, 2.5 s

#### **Attention\_S\_3T\_2s.wav**

- Three tone chime
- Vibraphone, C4/D4/D#4
- Peak level -3 dBFS, RMS level < -10 dBFS, 2 s

#### **Attention\_T\_3T\_3s.wav**

- Three tone chime
- Vibraphone, D5/C4/D4
- Peak level -4 dBFS, RMS level < -10 dBFS, 3 s

#### **Attention\_U\_3T\_3.5s.wav**

- Three tone chime
- Vibraphone, C#6/E5/C5
- Peak level -5 dBFS, RMS level < -10 dBFS, 3.5 s

## 31.3

### Silence tones

#### **Tone characteristics**

- Mono, sample rate 48 kHz, 16-bit sample depth.
- Filename format: Silence\_<duration>.wav

#### **Silence\_1s.wav**

- Silence period, 1 s

#### **Silence\_2s.wav**

- Silence period, 2 s

#### **Silence\_4s.wav**

- Silence period, 4 s

#### **Silence\_8s.wav**

- Silence period, 8 s

#### **Silence\_16s.wav**

- Silence period, 16 s

## 31.4

### Test tones

#### **Tone characteristics**

- Mono, sample rate 48 kHz, 16-bit sample depth.

#### **Test\_Loudspeaker\_AB\_20kHz\_10s.wav**

- Sine wave 20 kHz, peak level -20 dBFS, RMS level -23 dBFS, 10 s.
- Inaudible signal to drive the A-group loudspeakers and check the connectivity of the A- and B-loudspeakers simultaneously while the building is occupied. The B-loudspeakers get a 22 kHz signal.
- The A-loudspeakers are connected to their own zone amplifier channel. This zone gets the 20 kHz signal.
- Keep a smartphone in front of the loudspeaker. A smartphone spectrum analyzer detects both the 20 kHz and the 22 kHz simultaneously.

- **Note:** This tone can cause a false positive line supervision fault. Refer to *Resilience of EOL-supervision for high frequency tones*, page 289.

**Test\_Loudspeaker\_AB\_22kHz\_10s.wav**

- Sine wave 22 kHz, peak level -20 dBFS, RMS level -23 dBFS, 10 s.
- Inaudible signal to drive the B-group loudspeakers and check connectivity of the A- and B-loudspeakers simultaneously while the building is occupied. The A-loudspeakers get a 20 kHz signal.
- The B-loudspeakers are temporarily connected to another amplifier channel, for another zone; this zone gets the 22 kHz signal.
- Keep a smartphone in front of the loudspeaker. A smartphone spectrum analyzer detects both the 20 kHz and the 22 kHz simultaneously.
- **Note:** This tone can cause a false positive line supervision fault. Refer to *Resilience of EOL-supervision for high frequency tones*, page 289.

**Test\_LoudspeakerPolarity\_10s.wav**

- Filtered sawtooth 50 Hz, peak level -12 dBFS, RMS level -20 dBFS, 10 s.
- Audible signal to detect proper polarity of connected loudspeakers.
- A smartphone oscilloscope detects a positive or negative sharp peak that should be in the same direction for all loudspeakers.

**Test\_PinkNoise\_30s .wav**

- Pink noise signal 20 Hz - 20 kHz, peak level -3 dBFS, RMS level -16 dBFS, 30 s.
- Audible signal for acoustic measurements.

**Test\_STIPA\_BedrockAudio\_100s.wav**

- STIPA test signal, peak level -4.2 dBFS, RMS level -11 dBFS, 100 s.
- Test signal to measure the speech intelligibility through the Speech Transmission Index.
- Copyright Bedrock Audio BV (<http://bedrock-audio.com/>), used with permission.
- Compatible with all STIPA meters compliant to IEC 60268-16 Ed. 4 (Bedrock Audio, NTi Audio, Audio Precision).
- The signal can be looped. A 440 Hz beep signal of -12 dBFS, duration 1 s, marks the beginning of the 100 s test signal. Start the measurement after this beep, so the measurement will not be disturbed by a gap between the end and the restart.
- A measurement cycle takes a minimum of 15 s.

**Test\_TickTone\_1800Hz\_5x(0.5+2)s.wav**

- Intermittent 1800 Hz sinewave, 0.5 s on, 2 s off, 4 repetitions.
- Duty cycle 20%.
- Route the tick tone to a zone to deliver an audible bleep from each speaker in that zone. The loss of the tick tone along the line allows the engineer to identify the position of the line discontinuity.

**Test\_Reference\_440Hz\_10s.wav**

- Continuous 440 Hz sinewave, 10s.
- Duty cycle 100%.

**Refer to**

- *Resilience of EOL-supervision for high frequency tones*, page 289

## 32

## Support and academy



### Support

Access our **support services** at [www.boschsecurity.com/xc/en/support/](http://www.boschsecurity.com/xc/en/support/).

Bosch Security and Safety Systems offers support in these areas:

- [Apps & Tools](#)
- [Building Information Modeling](#)
- [Warranty](#)
- [Troubleshooting](#)
- [Repair & Exchange](#)
- [Product Security](#)



### Bosch Building Technologies Academy

Visit the Bosch Building Technologies Academy website and have access to **training courses**, **video tutorials** and **documents**: [www.boschsecurity.com/xc/en/support/training/](http://www.boschsecurity.com/xc/en/support/training/)











**Bosch Security Systems B.V.**

Torenallee 49

5617 BA Eindhoven

Netherlands

**[www.boschsecurity.com](http://www.boschsecurity.com)**

© Bosch Security Systems B.V., 2024

**Building solutions for a better life**

202403281015