

Installation Instructions for the RF3401/RF3401LM Wireless (RF) Point Transmitter

1.0 General Information

The RF3401 Point Transmitter is a magnetic and dry contact wireless transmitter used for monitoring doors, windows or other dry contact devices. The RF3401 is classified under UL634 as a Level 1 - High Security Switch.

The unit is equipped with an internal reed contact for use with an external magnet assembly, a cover tamper switch and RF supervision. The RF3401 also has the capability to accept a supervised dry contact input (2.2 kΩ EOL included) from an external device. Supervision is provided by transmitting a low power level signal to the receiver every 65 minutes if there is no other activity. All transmissions from the RF3401 send battery status information to the panel.

2.0 Specifications

- **Description:**
RF3401: with magnet assembly
RF3401LM: without magnet assembly
- **Dimensions (HxWxD):**
Transmitter: 1.4 in. x 3.25 in. x 0.75 in.
(35 mm x 77 mm x 19 mm)
Mounting Plate: 1.4 in. x 3.25 in. x 0.125 in.
(35 mm x 77 mm x 3 mm)
- **Operating Temperature:** -20°F to +150°F (-29°C to +65°C);
0 to 95% relative humidity
(non-condensing).
- **Operating Voltage:** Supplied by a 3 VDC lithium battery.
- **Battery Life:** More than 5 years under normal
operating conditions with the
recommended battery types.
- **Recommended Battery
Types:** Duracell DL123A, Panasonic
CR123A, or Sanyo CR123A.
- **Compatible Receivers:** RF3224, RF3222, RF3212, RF3213

NOTE: UL has not verified operation on the RF3212, RF3213, or RF3222. UL Listed for residential use only.

- **Options:** Magnet-RF-10 Assembly*
*Supplied in packages of 10
- **Compliance:** This device complies with Part 15 of
the FCC Rules and with RSS-210 of Industry and Science Canada.
Operation is subject to the following two conditions:
(1) this device may not cause harmful interference, and
(2) this device must accept any interference received, including
interference that may cause undesirable operation.

Changes or modifications not expressly approved by Bosch Security Systems, Inc. can void the user's authority to operate the equipment.

3.0 Mounting

3.1 Mounting Considerations



The maximum range of the Point Transmitter, in open air, is approximately 500 feet (150 m). In normal residential or commercial applications, it is recommended that the Point Transmitter be kept within 100 feet (30 m) of the receiver to which it is assigned.

- Mounting the Point Transmitter on metal surfaces may reduce its RF range. Mounting the Point Transmitter on ferrous metal (iron or steel) surfaces may affect the operation of the internal magnetic contact.
- It is recommended that the Point Transmitter be mounted on the frame of the door or window and that the Magnet Assembly be mounted on the moving portion.
- Note that the Magnet Assembly **must** be mounted within 1 in. to 1.25 in. (25 to 32 mm) of the Point Transmitter and in an acceptable orientation as shown in Figure 1.

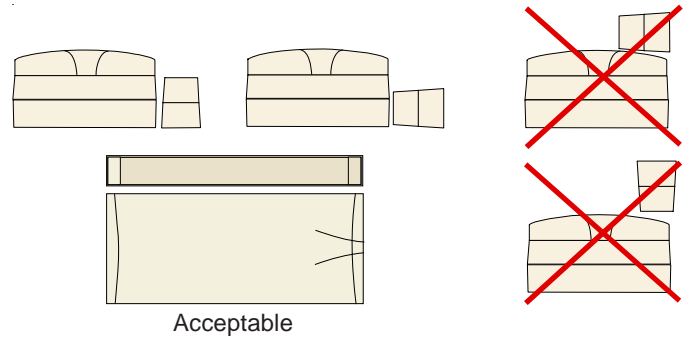

Figure 1 - Mounting Considerations
(shown without Mounting Plate or Spacer)

3.2 Mounting the Transmitter

- Position the Mounting Plate over the desired location. If connecting an external device, position the mounting plate so the wiring passes through the Wire Entrance (refer to Figure 2).
- Attach the Mounting Plate using the two flathead screws as shown in Figure 2.

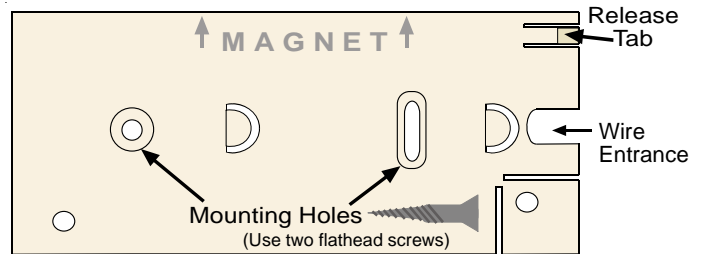

Figure 2 - Mounting Plate



Be sure to note the location of the magnet when mounting the base.

- Tear off the loose portion of the ID label for use in panel programming. Refer to Section 5.0.
- Depending on which case your Transmitter comes with (refer to Figure 3 on page 2), open the Transmitter Cover by inserting a small flat-blade screwdriver into the slot at the end of the Transmitter. Press in with the screwdriver until the Latch opens.

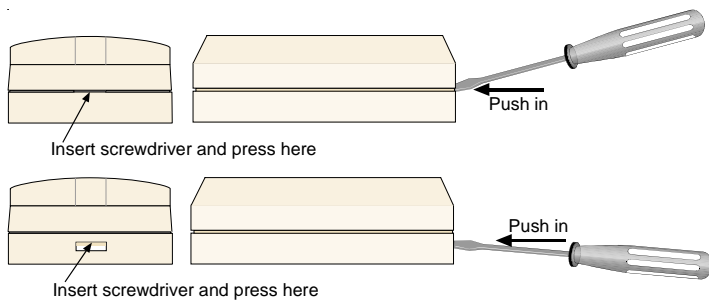

Figure 3 - Opening the Point Transmitter

- Slide the Point Transmitter over the Mounting Plate to lock it into place (refer to Figure 4). If connecting an external device, make sure that its wiring is pulled through the Wire Entrance of the Point Transmitter as the Point Transmitter slides onto the Mounting Plate.

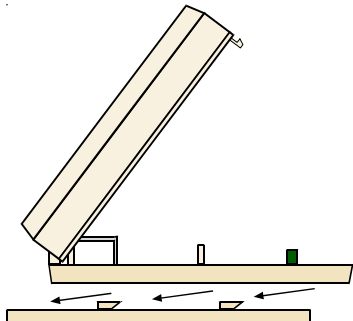

Figure 4 - Attaching Point Transmitter to Mounting Base

- Make wiring connections for any external device. Refer to Section 4.0 or 5.0 on page 3.
- If the external contacts will not be used, connect a 2.2 kΩ EOL resistor across the terminals (refer to Figure 5).

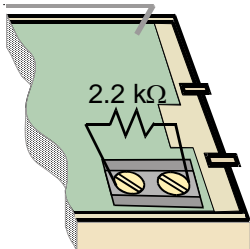

Figure 5 - EOL Resistor Connection

- If the installation requires additional security, use an additional panhead screw to mount the Point Transmitter as shown in Figure 6.

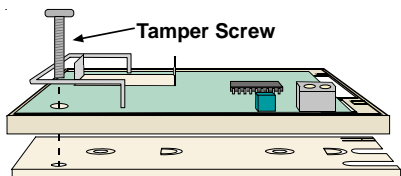

Figure 6 - Tamper Screw Installation

- Install a recommended battery (refer to Section 2.0 on page 1). Be sure to observe the proper polarity (refer to Figure 7).

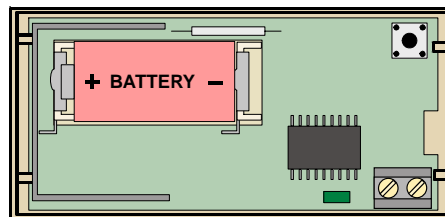

Figure 7 - Correctly-Installed Battery

- Close the cover.
- The Point Transmitter may be released from the base by disconnecting any external wiring, removing the security screw (if used), then pressing the Release Tab (refer to Figure 2) with a small tool and sliding the Point Transmitter off the Mounting Plate.

3.3 Mounting the Magnet Assembly



For proper functioning, use **only** the supplied Magnet Assembly.

- Mount the Magnet Base (refer to Figure 8) using two panhead screws.

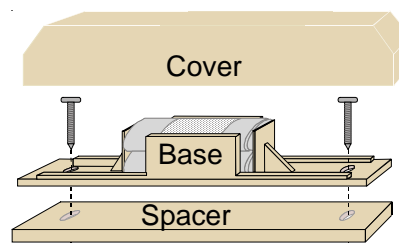

Figure 8 - The Magnet Assembly



The Spacer is optional and should be used if needed for alignment.

- Snap on Magnet Cover.

4.0 Setting Up Magnetic or External Contacts

4.1 With the RF3222 Receiver and DS7400Xi System

The RF3401 has the ability to monitor its internal reed contact or an external dry contact.



If using the RF3222 Receiver, the RF3401 cannot monitor both magnetic and external contacts at the same time.

If using the magnet, do **not** use an external device or an EOL resistor.

If using an external device, remove the reed switch (refer to Figure 9).

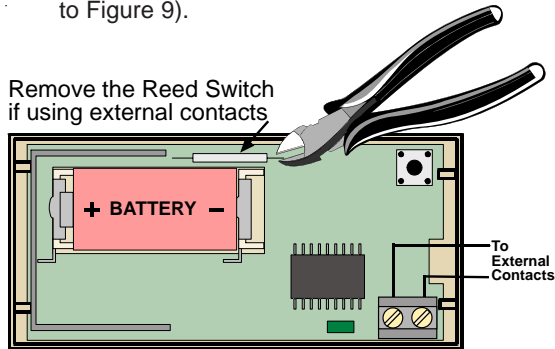

Figure 9 - Removing the Reed Switch



If using the RF3401 with Security Escort it is not necessary to remove the reed switch.

One set of **External Normally-Closed (NC) Contacts** (refer to Figure 9) or one set of **External Normally-Open (NO) Contacts** (refer to Figure 10) may be monitored. Be sure that your panel supports the intended loop condition.

The contact input is supervised using a 2.2 k Ω EOL resistor. This allows the panel to identify wire tamper conditions (opens or shorts). The total cable length for the external wiring should not exceed 20 ft. (6 m).

4.2 With the RF3212 Receiver and an EDM Panel

The RF3401 has the ability to monitor its internal reed contact and an external dry contact. The EDM panel remembers and learns the state of usage of the two alarm functions of the RF3401.

If the external zone is left open or shorted, then its state is ignored and the magnet is followed. Once the external loop is seen supervised with the EOL resistor, the loop becomes the predominant function and must be in the supervised state for the panel to report no faults for that zone.

Once both the magnet and supervised loop resistor have been seen by the panel, then they both must be present for the panel to report a normal status for that zone. If the loop is supervised and the magnet is present and then removed, the panel will report a trouble condition due to the missing magnet.

One set of **External Normally-Closed (NC) Contacts** (refer to Figure 10) or one set of **External Normally-Open (NO) Contacts** (refer to Figure 11) may be monitored. Be sure that your panel supports the intended loop condition.

The contact input is supervised using a 2.2 k Ω EOL resistor. This allows the panel to identify wire tamper conditions (opens or shorts). The total cable length for the external wiring should not exceed 20 ft. (6 m).

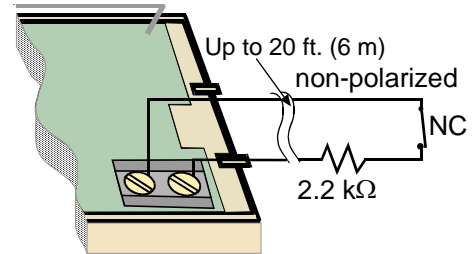

Figure 10 - Typical Normally-Closed (NC) Wiring

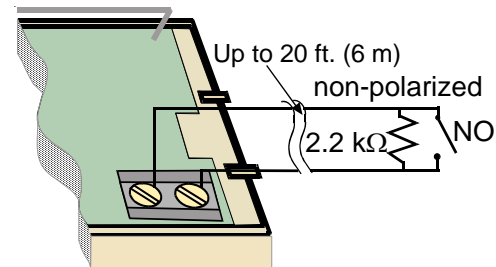

Figure 11 - Typical Normally-Open (NO) Wiring

5.0 Panel Programming

There is a label (refer to Figure 12) located on the housing. You will need the 9-digit number on this label to program the Point Transmitter into the Control Panel. See your panel's Programming Guide for programming information on wireless type devices.



Figure 12 - ID Number

