

Control/Communicators D2212B/D2212BE

Operation and Installation Guide



Contents

1.0	Introduction	7
1.1	Guide Organization	7
1.2	Other Literature Referenced	7
1.3	Documentation Conventions	8
1.3.1	Type Styles Used in this Guide	8
1.3.2	Tips, Notes, Cautions and Warnings	8
1.4	Listings and Approvals	8
1.5	FCC Notice	9
1.5.1	Part 15	9
1.5.2	Part 68	9
1.6	Canadian Compliance Notice	10
2.0	Overview	11
2.1	Specifications	11
2.2	D2212 Control/Communicator	12
2.2.1	Panel Assembly	12
2.2.2	Hardware Pack	13
2.2.3	Literature Pack (L2212-LIT)	13
2.3	Ordered Separately	13
2.3.1	D202A Keypad	13
2.3.2	D205 Keypad	13
2.3.3	D206 Keypad	13
2.3.4	D220A Keypad	14
2.3.5	D222 Keypad	14
2.3.6	D223 Keypad	14
2.3.7	Battery	14
2.3.8	D132A or D192C	14
2.4	Enclosure Options	14
3.0	Installation	15
3.1	Mount the Enclosure	15
3.1.1	Mounting the D2212B in the D2203 Enclosure	15
3.1.2	Mounting the D2212BE in the D2803 Enclosure	15
3.2	Run the Premises Wiring	15
3.2.1	Wire Length	15
3.2.2	EMI (Electro Magnetic Interference)	16
3.3	Connect to Earth Ground	16
3.4	Transformer (16.5 VAC)	16
3.5	Battery	16
3.6	Charge the Battery as You Work	16
3.6.1	Lock the Standby Switch	16
3.7	Install Detection Devices, Keypads and Bells	17
3.7.1	No Connection to the Panel Yet	17
3.7.2	Number of Sensors	17
3.8	Continue Connections to the Panel	17
3.8.1	Power Down First	17
3.8.2	Alarm Output (+Alarm-)	17
3.8.2.1	Available Power	17
3.8.2.2	Fire System Power Formula	17
3.9	Keypads (Data and + Aux -)	17
3.10	Auxiliary Power (+Aux)	18
3.11	External Relays (Ext1 and Ext2)	18

Contents

4.0	Power Module	19
4.1	Primary (AC) Power Circuit	19
4.1.1	AC Power Failure	19
4.2	Secondary (DC) Power	19
4.2.1	Lead Acid Batteries Only	19
4.2.2	Battery Replacement	19
4.2.3	Battery Supervision	19
4.2.4	Investigate Low Battery Reports Immediately	19
4.2.5	Battery Charging Circuit Float Charge	19
4.2.6	Battery Discharge/Recharge Schedule (No AC Power)	20
4.2.6.1	Discharge Cycle	20
4.2.6.2	Recharge Cycle	20
4.3	Power Outputs	20
4.3.1	D2212 Circuit Protection	20
4.3.2	Extra Power for Keypads or Other Powered Devices	20
4.4	Point Parameters	20
4.4.1	On-Board Point 1	20
4.4.2	Points 2 to 6	20
4.4.3	Point Response Time	20
5.0	Telephone Connections	21
5.1	Phone Jack	21
5.2	Phone Cord	21
5.3	Power Up	21
5.4	Program the Panel	21
5.5	Unlock the Standby Switch	22
5.5.1	RAM II Reset Bye Does Not Disarm the Panel	22
5.6	Check for Alarm Verification	22
5.7	Test the System	22
5.7.1	Clear After Test	22
5.8	Dialing Format	22
5.9	Communication Failure	23
5.10	Ground Start	23
6.0	On-Board Points	25
6.1	Point 1 (1+ and 1-)	25
6.2	Points 2 through 6	25
6.3	Points 7 and 8	25
6.4	Point Expanders for the D2212B, Wired or RF	26
7.0	Arming Devices	27
7.1	Keyswitch	27
7.1.1	Description	27
7.1.2	Programming	27
7.1.3	Installation	27
7.1.4	Keyswitch Operation	27
7.1.5	Silencing the Bell	27
7.1.6	Easikey	28
Appendix A: System Wiring Diagram, Issue A		29
Appendix B: Terminal Quick Reference		31
Appendix C: Installation Guide for UL Applications		33
Appendix D: System Chart		37
Index	39

Figures

Figure 1: D2203 Enclosure 15
Figure 2: D2803 Enclosure 15
Figure 3: Standby Switch 16
Figure 4: Keypad Wiring 18
Figure 5: External Relay Wiring 18
Figure 6: Power for Keypads 20
Figure 7: RJ31X Phone Jack 21
Figure 8: Phone Cord 21
Figure 9: Programmer Jack 22
Figure 10: Standby Switch 22
Figure 11: D133 for Ground Start 23
Figure 12: Points 26
Figure 13: Keyswitch 27
Figure 14: Easikey Wiring 28
Figure 15: D2212 System Wiring Diagram, Issue A 29

Tables

Table 1: D2212B/D2212BE Guide Organization 7
Table 2: Referenced Literature 7
Table 3: D2212B/D2212BE Specifications 11
Table 4: D2212B/D2212BE Compatible Enclosures and Accessories 12
Table 5: D2212 Terminal Reference 31
Table 6: Current Rating Chart for Standby Battery Calculations 35
Table 7: System Chart 37

Contents

1.0 Introduction

1.1 Guide Organization

This guide is divided into eleven sections, summarized in *Table 1* below.

Section	Description
1	Introduction – this section
2	Overview – provides an overview of the D2212, including operational specifications
3	Installation – provides installation instructions
4	Power Module – provides wiring instructions
5	Telephone Connections – provides information on connecting the phone line and programming it for use
6	On-Board Points – provides information on the on-board points and their parameters
7	Arming Devices – provides information on connecting the Arming Devices
Appendix A	System Wiring Diagram – shows the terminal wiring connections
Appendix B	Terminal Quick Reference Chart – provides a quick description of the various terminals on the panel
Appendix C	Installation for UL Applications – provides instructions for UL approved installations
Appendix D	System Chart – shows the minimum requirements for a system based on common applications

Table 1: D2212B/D2212BE Guide Organization

1.2 Other Literature Referenced

See *Table 2* for a listing of related D2212B/D2212BE Control/Communicator documents. They have been included in the table below with their part numbers for easy ordering. Contact Bosch Security Systems if you need to order additional literature.

Document Name	Bosch Security Systems Part Number
<i>D2000 Series Control/Communicator Program Entry Guide</i>	35114
<i>D2000 Series Control/Communicator Technogram</i>	35112
<i>D5200 Programming Operation Guide</i>	74-06176-000
<i>Easikey 1000/1000 Plus Door Controller Installation and Programming Guide</i>	74-07579-000

Table 2: Referenced Literature

Introduction

1.3 Documentation Conventions

1.3.1 Type Styles Used in this Guide

We use special type styles to help you identify the objects that we are describing in this guide.

Bold text	Usually indicates selections that you may use while programming your panel. May also indicate an important fact that you should note.
<i>Bold Italicized text</i>	Denotes notes, cautions, and/or warnings.
<i>Italicized text</i>	Refers you to a drawing, table, or other section of this document, or to another document. Also used to symbolize names for records that you create.
Courier New text	Indicates what may appear on the D5200 Programmer display, command center/keypad or internal printer.
[CAPITALIZED TEXT]	Indicates a specific key to be pressed.

1.3.2 Tips, Notes, Cautions and Warnings

Throughout this document, helpful tips and notes will be presented concerning the entire application and/or programming the unit. They are set off as follows:



The possibility of physical damage to the operator, equipment and/or proper execution of the program.



Cautions the operator that physical damage to the equipment or improper execution of the program may occur.



Important Notes should be heeded for successful operation and programming. Helpful tips and/or shortcuts may be included here.

1.4 Listings and Approvals

The D2212B and D2212BE have the following approvals:

Fire

- Underwriters Laboratories as a Household Fire and Burglary Warning System Control Unit for NFPA 72 (Chapter 2) Household Fire Warning
- CSFM (Residential)
- UL 985 Household Fire Warning Systems

Burglary

- UL 1023 Household Burglary Alarm
- UL 365 Police Station Connect
- UL 609 Local Burglary Alarm
- UL 1076 Proprietary Burglary Alarm
- UL 1610 Central Station

1.5 FCC Notice**1.5.1 Part 15**

This equipment has been tested and found to comply with the limits for a Class B digital device, pursuant to Part 15 of the FCC Rules. These limits are designed to provide reasonable protection against harmful interference in a residential installation. This equipment generates, uses, and can radiate radio frequency energy, and, if not installed and used in accordance with the instruction guide may cause harmful interference to radio communications. However, there is no guarantee that interference will not occur in a particular installation. If this equipment does cause harmful interference to radio or television reception, which can be determined by turning the equipment off and on, the user is encouraged to try to correct the interference by one or more of the following measures:

- Reorient or relocate the receiving antenna.
- Increase the separation between the equipment and the receiver.
- Connect the equipment into an outlet on a circuit different from that to which the receiver is connected.
- Consult the dealer or an experienced radio/TV technician for help.

1.5.2 Part 68

This equipment complies with Part 68 of FCC rules. A label contains, among other information, the FCC registration number and ringer equivalence number (REN).

Bosch Security Systems registered the D2212 Control/Communicator for connection to the public telephone network using an RJ31X jack.

Use the ringer equivalence number (REN) to determine the number of devices you can connect to the telephone line. Excessive RENs on the telephone line may result in devices not ringing in response to an incoming call. In most, but not all areas, the sum of the RENs should not exceed five (5). Contact the telephone company to determine the maximum REN for the calling area.

If the D2212 Control/Communicator causes harm to the telephone network, the telephone company will notify you in advance. If advance notice isn't practical, the telephone company will notify the customer as soon as possible. Also, you will be advised of your right to file a complaint with the FCC if you believe it is necessary.

The telephone company may make changes in its facilities, equipment, operations, or procedures that could affect the operation of the D2212. If this happens, the telephone company will provide advance notice in order for you to make the necessary modifications to maintain uninterrupted service.

If you experience trouble with the D2212 Control/Communicator, please contact Bosch Security Systems Customer Service for repair and/or warranty information. If the trouble is causing harm to the telephone network, the telephone company may request that you remove the D2212 from the network until the problem is resolved. User repairs must not be made. Doing so voids the user's warranty.

Do not install the D2212 on public coin service provided by the telephone company. Connection to Party Line service is subject to state tariffs (contact your state public utilities commission for information). You must supply the local telephone company with the following information at their request:

- The line you are going to connect the panel to.
- Make (Bosch Security Systems), model (D2212), and serial number of the panel.
- FCC registration number and ringer equivalence for the panel.

FCC Registration Number: ESVUSA-30727-AL-E

Service Center in USA:

National Repair Center

Ringer Equivalence: 0.3B

130 Perinton Parkway

Fairport, NY 14450-9199

(800) 289-0096 x4220

Introduction

1.6 Canadian Compliance Notice

The Industry Canada label identifies certified equipment. This certification means that the equipment meets certain telecommunications network protective, operational, and safety requirements. Industry Canada does not guarantee the equipment will operate to the user's satisfaction.

Before installing this equipment, users should ensure that it is permissible to be connected to the facilities of the local telecommunications company. The equipment must also be installed using an acceptable method of connection. The customer should be aware that compliance with the above conditions may not prevent degradation of service in some situations.

Repairs to certified equipment should be made by an authorized Canadian maintenance facility designated by the supplier. Any repairs or alterations made by the user to this equipment, or equipment malfunctions, may give the telecommunications company cause to request the user to disconnect the equipment.

Users should ensure for their own protection that the electrical ground connections of the power utility, telephone lines and internal metallic water pipe system, if present, are connected together.



Users should not attempt to make such connections themselves, but should contact the appropriate electric inspection authority, or electrician, as appropriate.

2.0 Overview

2.1 Specifications

Voltage input (Power Supply)	Primary	D2412U: 16.5 VAC 40 VA 2 plug-in transformer (D1640) D2412UE: 16.5 VAC 25VA 2 plug-in transformer (D1625)	
	Secondary	12 VDC 7.0 Ah sealed lead acid rechargeable battery	
Power Outputs	Auxiliary Power Output	D2212B	1.0 A maximum at 10.2 VDC to 13.9 VDC for devices powered at the Aux+ terminal (140 mA for Fire and combined Fire/Burglary systems)
		D2212BE	500 mA maximum at 10.2 VDC to 13.9 VDC for devices powered at the Aux+ terminal (140 mA for Fire and combined Fire/Burglary systems)
	Alarm Power Output	1.35 A maximum at 10.2 VDC to 13.9 VDC output. Output may be steady or pulsed depending on programming.	
	Fire and Fire/ Burglary Systems	To comply with UL 985 Listing standards for household fire alarm systems (effective March 1, 1989), the total combined continuous and alarm current draw for the system during alarm conditions must be limited to 860 mA provided by the primary power supply (rectified AC).	
Operating Voltage	Minimum	10.2 VDC	
	Maximum	13.9 VDC	
Telephone Connection		RJ31X or RJ38X jack interfaced with D164 phone cord	
Environmental	Temperature	+32°F to +122°F (0° to +50°C)	
	Relative Humidity	5 to 85% @ +86°F (+30°C) non-condensing	
Arming Stations		D202A Keypad D205 Keypad D206 Keypad D220A Keypad D222 Keypad D223 Keypad D204RF Keypad Keychain Keypad (60-606-319.5) Keyswitch Easikey	

Table 3: D2212B/D2212BE Specifications

D2212B/D2212BE

Overview

Compatible Enclosures		D2203 Standard Enclosure D2803 Standard Enclosure (D2412UE only) D8103 Universal Enclosure D8109 Fire Enclosure D8109A Attack Resistant Enclosure
Compatible Accessories	D126 D127 D132A D133 D134 D135A D164 D168 D169 D192C D202A D204RF D208RF D216RF D220A D222 D223 D250 D254 D255 D261A D262 D440 D442 D448 D1640 D2402 D5200 D5300 D8004 D8121/D8122 D282THS D282/D282TH Easikey	12 V, 7 Ah Rechargeable Battery Reversing Relay Smoke Detector Reversing Relay Module (Required for fire or combined fire/burglary systems if D192C is not used. Use only with compatible smoke detectors.) Relay Module Dual Relay Module Low Battery Cutoff Module (not UL Listed) Phone Cord Telephone Arming Module 2-Way Voice Verification Module (<i>NOT UL Listed. NOT suitable for Fire and combined Fire/Burglary installations. NOT suitable for UL Certificated Burglary installations.</i>) NAC Supervision Module (required if D132A is not used) Keypad Keypad (not UL Listed) Receiver Receiver Keypad Keypad Keypad Heat Detector Base 135° Fixed Point Thermostat 190° Fixed Point Thermostat Smoke Detector Base Smoke Detector Head 6 in. Bell 8 in. Bell 12 VDC Horn 16.5 VAC 20 VA Transformer Mounting Skirt (required for use with D8103, D8109, D8109A) Programmer Remote Account Manager II Transformer Enclosure Derived Channel STU (use D8122 for UL systems) Smoke Detector with Sounder Smoke Detector (not for use in UL systems)

Table 4: D2212B/D2212BE Compatible Enclosures and Accessories

2.2 D2212 Control/Communicator

The Bosch Security Systems D2212 Control/Communicator is shipped pre-assembled from the factory. You should receive the following parts with your D2212 panel.

2.2.1 Panel Assembly

- D2212B or D2212BE Panel
- D2203 Enclosure for D2212B
- D2803 for D2212BE
- D1640 Transformer for D2212B

- D1625 for D2212BE
- *D2000 Series Control/Communicator Technogram* (P/N: 35112)
- *Release Notes: Firmware Revision* (P/N: 35111)

2.2.2 Hardware Pack

- One 2 kΩ EOL resistor for Point 1 (P/N: 15-03130-010)
- Five 1 kΩ EOL resistors for Points 2 to 6 (P/N: 30-01098-102)
- Two #6 by 3/8 in. sheet metal screws to secure the enclosure cover
- Four plastic clips for mounting the panel to the enclosure
- Two thread forming screws for mounting the panel to the enclosure

2.2.3 Literature Pack (L2212-LIT)

- *D2212B/D2212BE Control/Communicator Installation Guide* (P/N: 39934)
- *D2000 Series Control/Communicator Program Entry Guide* (P/N: 35114)
- *Program Record Sheet* (P/N: 35113)
- *Keypad Diagnostics Sheet* (P/N: 35110)

2.3 Ordered Separately**2.3.1 D202A Keypad**

Each D202A includes the following:

- D202A Keypad
- *Installation Instructions* (P/N: 74-07118-000)
- User's Cards (P/N: 71-07090-000)
- *Security System User's Guide* (P/N: 71-07117-000)
- *Getting Started with Your Security System* (P/N: 71-07372-000)
- Three-wire data cable assembly (P/N: 15-07032-000)

2.3.2 D205 Keypad

Each D205 includes the following:

- D205 Keypad
- *Installation Instructions* (P/N: 31945)
- *Security System User's Guide* (P/N: 71-07117-000)
- *Getting Started with Your Security System* (P/N: 71-07372-000)
- Three-wire data cable assembly (P/N: 15-07032-000)

2.3.3 D206 Keypad

Each D206 includes the following:

- D206 Keypad
- *Installation Instructions* (P/N: 31946)
- *Security System User's Guide* (P/N: 71-07117-000)
- *Getting Started with Your Security System* (P/N: 71-07372-000)
- Three-wire data cable assembly (P/N: 15-07032-000)

Overview

2.3.4 D220A Keypad

Each D220A includes the following:

- D220A Keypad
- *Installation Instructions* (P/N: 74-07363-000)
- *User's Reference Card* (P/N: 71-05432-011)
- *Security System User's Guide* (P/N: 71-07374-000)
- *Getting Started with Your Security System* (P/N: 71-07372-000)
- Three-wire data cable assembly (P/N: 15-07032-000)

2.3.5 D222 Keypad

Each D222 includes the following:

- D222 English Keypad and Point Expander
- *Installation Instructions* (P/N: 74-07362-000)
- *User's Reference Card* (P/N: 71-04523-010)
- *Security System User's Guide* (P/N: 71-07374-000)
- *Getting Started with Your Security System* (P/N: 71-07372-000)
- Three-wire data cable assembly (P/N: 15-07032-000)
- Six-wire point cable assembly (P/N: 15-07251-000)
- Four 1 k Ω EOL resistors (P/N: 30-01098-102)

2.3.6 D223 Keypad

Each D223 includes the following:

- D223 English Keypad
- *Installation Instructions* (P/N: 74-07490-000)
- *User's Reference Card* (P/N: 71-04523-010)
- *Security System User's Guide* (P/N: 71-07373-000)
- *Getting Started with Your Security System* (P/N: 71-07372-000)
- Three-wire data cable assembly (P/N: 15-07032-000)

2.3.7 Battery

Order a **D126 Battery** (12 V 7.0 Ah) to complete a basic D2212 installation.

2.3.8 D132A or D192C

A D132A Smoke Detector Reversing Relay Module (and compatible smoke detectors), or a D192C NAC Supervision Module must be used for fire or combined fire/burglary installations.

2.4 Enclosure Options

The D2212B is shipped in the D2203 enclosure; the D2212BE is shipped in the D2803. If you want to mount the D2212B or D2212BE in one of the optional enclosures listed below, order the D2212BM or D2212BEM, and the enclosure of your choice.

- D8103 Universal Enclosure
- D8108A Attack Resistant Enclosure
- D8109 Fire Rated Enclosure

3.0 Installation

Review this guide before you begin to determine hardware and wiring requirements for the features you want to use. Have the following handy as you read through the guide:

- *D2000 Series Program Record Sheet* (P/N: 35113)
- *D2000 Series Control/Communicator Program Entry Guide* (P/N: 35114)
- *Security System User's Guide* for your keypad

3.1 Mount the Enclosure

3.1.1 Mounting the D2212B in the D2203 Enclosure

1. Open the cover to access the mounting holes in the rear of the enclosure. Note the wiring label on the inside of the enclosure cover.
2. Mount it in the desired location. Be sure there is enough clearance to open the door for maintenance.
3. Mount the panel to the enclosure as shown in *Figure 1*. Mount so the heat sink is at the left and the terminals are at the right and bottom. Be sure to use the four plastic stand-offs between the enclosure and the board (then secure with the two screws provided - at the right top and right bottom).

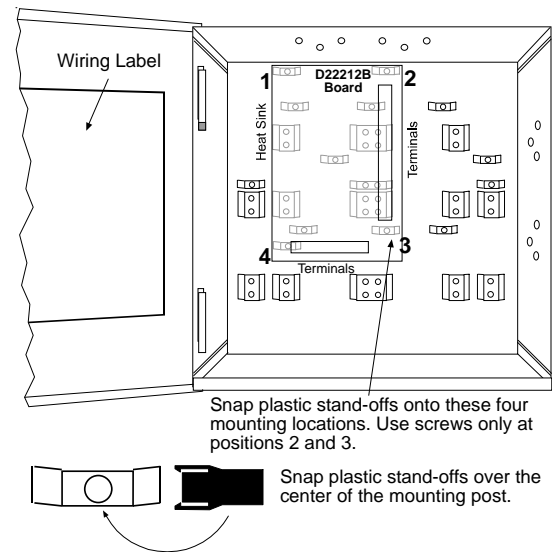

Figure 1: D2203 Enclosure

3.1.2 Mounting the D2212BE in the D2803 Enclosure

Mount the D2212BE into the D2803 Enclosure as shown in *Figure 2*. Be sure there is enough clearance to open the door for maintenance. Insert the two support posts in the retainer holes. Slide the top of the panel into the two retainer tabs. Once in the tabs, the panel rests on the two support posts. Secure the panel with the supplied screws.

3.2 Run the Premises Wiring

Run the necessary wiring throughout the premises and pull the wires into the enclosure. Do not make any connections yet.

3.2.1 Wire Length

Wire length for points is limited only by the resistance on the loop and potential EMI (Electro Magnetic Interference) problems.

Wire resistance on the Point 1 sensor loop must be less than 50 Ω .

Measure the wire resistance before installing smoke detectors. Short the EOL resistor before metering the wire.

Resistance on the sensor loops for Points 2 to 6 must be less than 100 Ω with the EOL resistor shorted and the detection devices connected.

Maximum wire length for the transformer is 50 ft. (15.2 m) (18 AWG/1.2 mm, stranded).

Maximum wire length for all keypads and point expanders combined is 500 ft. (152.4 m) (22 AWG/0.8 mm).

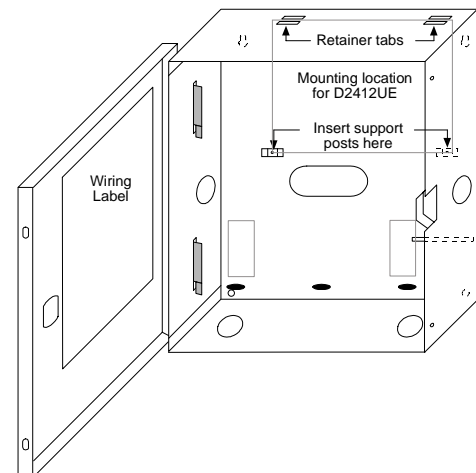

Figure 2: D2803 Enclosure

Installation

3.2.2 EMI (Electro Magnetic Interference)

AC wiring can induce EMI (both noise and low level voltage) into adjacent wiring. Run phone and sensor loop wiring away from AC conductors, including the transformer wire. Run keypad wiring away from AC and phone wiring.

EMI may also occur if you install the panel or run system wires near the following:

- Computer network system
- Fluorescent fixtures
- Telephone cabling
- Ham radio transmitter site
- Heavy machinery and motors
- High voltage electrical equipment
- PBX telephone system
- Public service (police, fire departments, etc.) using radio communications
- Radio station transmitter site, or other broadcasting station equipment
- Welding shop

If you think that EMI may be a problem, use shielded cable. The drain wire for the shielded cable must have continuity from the earth ground terminal on the control panel, to the end of the wire run.

3.3 Connect to Earth Ground

To help prevent damage from electrostatic charges or other transient electrical surges, connect the panel to earth ground at the panel's earth ground terminal before making any other connections.

A grounding rod or cold water pipe are recommended earth ground references.

Bosch Security Systems does not recommend a telephone or electrical ground for the earth ground connection. Use 18 AWG (1.2 mm) wire maximum under the terminal. Use a spade lug or splice for a larger wire.

Do not connect any other panel terminals to earth ground. The panel's common terminals and earth ground terminal are electrically isolated.

3.4 Transformer (16.5 VAC)

Connect the transformer to the terminals marked 16.5 VAC before plugging it into the power source.

Use 18 AWG (1.2 mm) wire to connect the transformer to the panel. Wire length should be kept as short as possible. Maximum wire length is 50 ft. (15 m).



Never share the transformer with other equipment: Foreign grounds on the AC input may damage the panel's power circuit.

3.5 Battery

Place the battery upright in the base of the enclosure. First plug the connector on the negative (black) battery wire to the negative (-) side of the battery.

Next plug the connector on the positive (red) battery wire to the positive (+) side of the battery.

3.6 Charge the Battery as You Work

3.6.1 Lock the Standby Switch

Locking the pin in the standby position allows you to charge the battery as you install the detection devices and keypads. Lock the pin down now (see *Figure 3*).

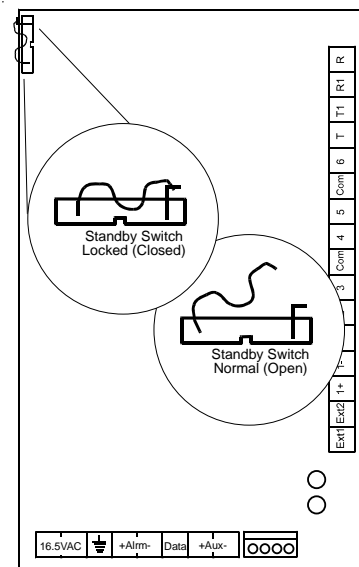

Figure 3: Standby Switch

With the Standby Switch locked down, the panel deactivates the external relay outputs, suppresses reports, and disables all arming functions.

Note: *Lock the Standby Switch down to program the panel locally, from the keypad, or the D5200.*

Releasing the Standby Switch from the closed position resets the panel. The panel resets all its timers and counters, and clears all buffers. If the panel is armed, releasing the standby switch causes the panel to disarm.

3.7 Install Detection Devices, Keypads, and Bells

3.7.1 No Connection to the Panel Yet

Install and wire detection devices, keypads, and indicating devices (bells, sirens, or strobes for example) at their locations throughout the premises. **Do not** make the connections at the panel end of the wiring yet.

3.7.2 Number of Sensors

When using Point 1 as a fire point, the number of detection devices you can connect to its sensor loop is limited. See Point 1 in *Section 6.1 Point 1 (1+ and 1-)* on page 25.

The number of detection devices you can connect to the sensor loops for Points 2 to 6 is limited only by the resistance on the loop. Resistance must be less than 100 Ω with the detection devices connected.

3.8 Continue Connections to the Panel

3.8.1 Power Down First

Unplug the transformer and disconnect the battery to make the remaining connections to the panel.

3.8.2 Alarm Output (+Alrm-)

The Alarm Output terminals provide a 10.2 VDC to 13.9 VDC output when activated. **The positive (+) terminal provides steady positive output.** The negative (-) terminal provides a pulsed or steady negative output as programmed.

Use this power for bells, siren drivers, piezo fire sounders, electronic horns, or other devices.

3.8.2.1 Available Power

The panel combines power produced by the power supply with power from the secondary power source (the battery) to produce a total of 1.35 A of **alarm** power at the Alarm Output terminals.

3.8.2.2 Fire System Power Formula

To calculate the current available at the Alarm Output terminals for fire and combined fire/burglary systems:

1. Add together the current draws for all devices connected to the negative alarm output terminal. This total is the current required for the Normal Standby Condition (NSC). This total must be less than 140 mA.
2. Subtract the NSC current required calculated in step 1 from the Primary Alarm Current, 860 mA. The difference is the Alarm Current available for the Alarm Output terminals.

In formula format: Primary Alarm Current - NSC current required = Alarm current available

3.9 Keypads (Data and + Aux -)

You can connect a combination of up to eight keypads and two types of point expanders (wired or RF) to the panel. Four keypads with expanders can have points assigned to them.

The installation sheet packed with each keypad contains mounting instructions. Wire keypads and other devices to the panel in parallel as shown in *Figure 4* on page 18.



You must use a minimum of 5 ft. (1.5 m) of wire (22 AWG / 0.8 mm) when connecting the keypad to the panel. A short on the positive Aux terminal within 5 ft. (1.5 m) of the panel prevents the panel from operating correctly.

Maximum wire length for all devices connected to Data and Aux (+,-) terminals combined is 500 ft. (152.4 m [22 AWG/ 0.8 m]).

Extra power needed for more keypads. Review Power Outputs in *Section 4.3, Power Outputs* on page 20 to determine the total power output requirements for your system. Instructions for using stand-alone power supplies are included.

Installation

D132A or D192C required for fire and combined fire/burglary systems:

Fire installations require a D132A Smoke Detector Reversing Relay Module, or a D192C NAC Supervision Module. The alarm output for fire or combined fire/burglary installations must be supervised. Use a D132A and compatible smoke detectors, or a D192C.

3.10 Auxiliary Power (+Aux)

The continuous current draw for powered devices connected to the +Aux terminal, including keypads, must not exceed 1.0 A (140 mA for fire and combined fire/burglary systems). For the D2212BE, the continuous current draw must not exceed 500 mA (140 mA for fire and combined fire/burglary systems). Devices powered from this output must operate over a range of 10.2 VDC to 13.9 VDC.



You must use a minimum of 5 ft. (1.5 m) 22 AWG (0.8 mm) of wire when connecting devices mounted outside the enclosure to the +Aux terminal. A short on the +Aux terminal within 5 ft. (1.5 m) of the panel prevents the panel from operating correctly.

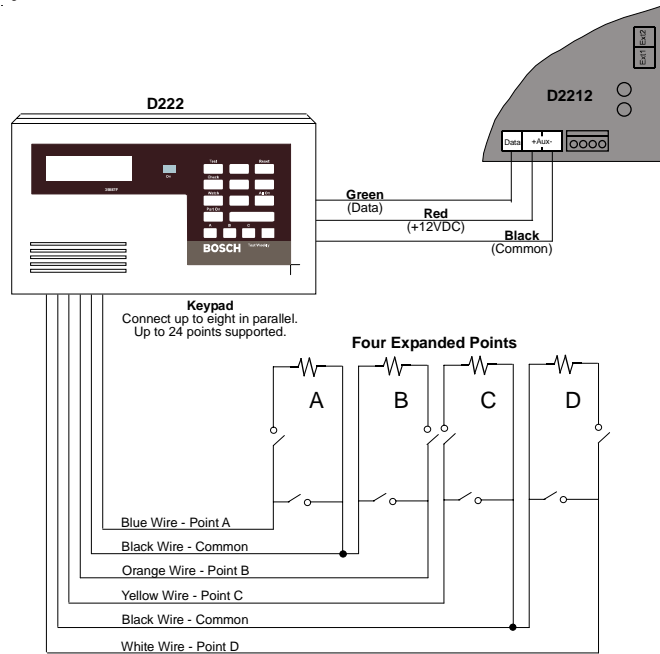

Figure 4: Keypad Wiring

3.11 External Relays (Ext1 and Ext2)

You can program the External Relay terminals to provide outputs for two external relays. Review the *RELAYS Group* in the *D2000 Program Entry Guide* (P/N: 35114) for a description of the relay functions available.

Connect a D133 (or D134) Relay Module for each of the external relay outputs you intend to use. *Figure 5* shows the connections (the D134 combines the functionality of two D133 relays in a single enclosure.).



Do not connect wiring for external relays directly to Ext1 or Ext2. Install D133 (or D134) modules connected to Ext1 and Ext2 in the enclosure with the panel.

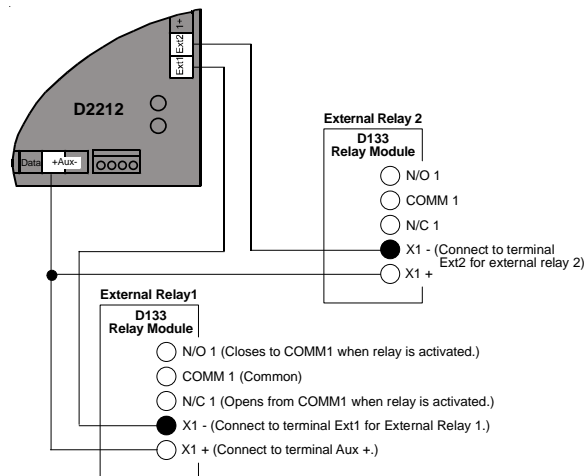

Figure 5: External Relay Wiring

4.0 Power Module

4.1 Primary (AC) Power Circuit

A 16.5 VAC, 40 VA transformer (Bosch Security Systems D1640) is the primary power source for the D2212B panel.

The AC power circuit for the D2212B provides 1.5 A of rectified DC power. The panel reserves 1.0 A of this power for internal operations and 1.0 A for continuously powered devices. Under alarm conditions 860 mA of power is available for continuously powered and alarm indicating devices combined.

A 16.5 VAC, 25 VA transformer (Bosch Security Systems D1625) is the primary power source for the D2212BE panel.

The AC power circuit for the D2212BE provides 1.0 A of rectified DC power. The panel reserves 140 mA of this power for internal operations and 500 mA for continuously powered devices. Under alarm conditions 860 mA of power is available for continuously powered and alarm indicating devices combined.

Transient suppressors and spark gaps protect the circuit from power surges. This protection relies on the ground connection. Make sure the panel's ground terminal is connected to a proper ground.

4.1.1 AC Power Failure

The panel indicates an AC power failure when power at the terminals labeled 16.5 VAC is missing for 60 sec. The *AC Fail Buzz/Rpt* program item sets the panel's response to detected AC failure. The panel indicates an AC power restoral 60 sec. after power restores to the terminals labeled 16.5 VAC.

4.2 Secondary (DC) Power

A 12 V, 7.0 Ah sealed lead-acid rechargeable battery (Bosch Security Systems D126) supplies secondary power for auxiliary and alarm outputs. The battery also powers the system during interruptions in primary (AC) power.

4.2.1 Lead Acid Batteries Only

The panel charging circuit is only calibrated for lead-acid batteries. Do not use gel-cell or nicad batteries.

4.2.2 Battery Replacement

Bosch Security Systems recommends battery replacement every three to five years under normal use. Exceeding the maximum output ratings, or installing the transformer in an outlet that is routinely switched off, causes heavy discharges. Routine heavy discharges can lead to premature battery failure.

D135A Prevents Deep Discharge: The D135A Low Battery Cutoff Module protects the battery from deep discharge during extended power outages. Deep discharge can cause permanent battery damage.

4.2.3 Battery Supervision

When the battery drops to 12.1 VDC the keypad indicates a trouble condition. The panel transmits a BATTERY LOW report.

When the battery voltage returns to 13.0 VDC and there is AC power at the terminals labeled 16.5 VAC, the keypad returns to normal operation. The panel transmits a BATTERY RESTORAL report.

4.2.4 Investigate Low Battery Reports Immediately

If primary (AC) power is off and the discharge continues, the panel becomes inoperative when the battery voltage drops below 10.2 VDC.

If the battery is disconnected, it takes 60 sec. for the panel to recognize the condition.

4.2.5 Battery Charging Circuit Float Charge

The float voltage for the battery charging circuit is 13.9 VDC. Deduct any continuous load for devices connected to the panel from 1.0 A to find the maximum current available for charging. At 13.9 VDC the battery is fully charged and is maintained with a trickle charge of approximately 5.0 mA.

D2212B/D2212BE

Power Module

4.2.6 Battery Discharge/Recharge Schedule (No AC Power)

4.2.6.1 Discharge Cycle:

- AC OFF The keypad indicates trouble. AC Fail reports if programmed.
- 13.9 VDC Charging float level.
- 12.1 VDC Low Battery reports.
- 10.2 VDC Panel shuts down below 10.2 VDC.

4.2.6.2 Recharge Cycle:

- AC ON: Panel restarts, battery charging begins, AC restoral report sent.
- 13.0 VDC Battery restoral reports sent, the keypad returns to normal operation.
- 13.9 VDC Battery float charged.

4.3 Power Outputs

4.3.1 D2212 Circuit Protection

Two self-resetting protection devices protect the panel from short circuits on both the auxiliary and alarm power outputs.

Bell circuit protection: A short on the alarm power output while the bell is ringing disables this output until it times out or you perform a panel reset.

4.3.2 Extra Power for Keypads or Other Powered Devices

You may need to add one or more D8132 Battery Charger/Power Supply Modules for the number of keypads you want to use. *Figure 6* shows the D8132 powering keypads in a stand-alone configuration.

For UL Certificated accounts, use a UL Listed power supply. The D8132 is not UL Listed as a stand-alone power supply for fire and burglary applications.

D2212 and D8132 (or other power supply) must share COMMON: Note that *Figure 6* shows the common from the D8132 module connected to both keypad's common and the Aux- (common) terminal on the panel. Do not connect the stand-alone power supply to earth ground.

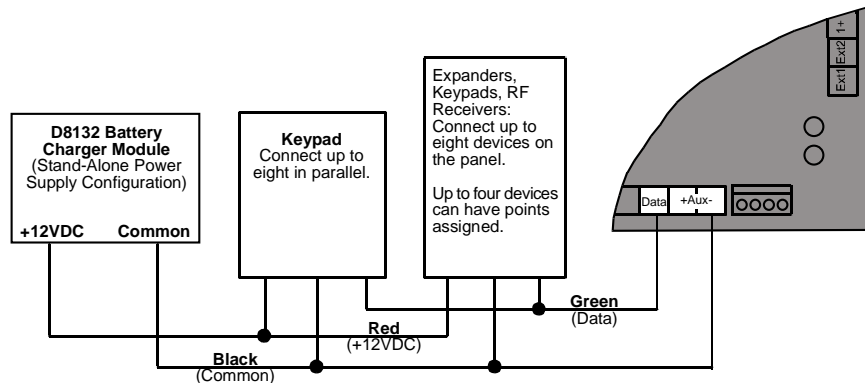

Figure 6: Power for Keypads

4.4 Point Parameters

4.4.1 On-Board Point 1

Point 1 is a powered sensor loop. Review the Bosch Security Systems *D2000 Series Control/Communicator Technogram* (P/N: 35112) for a list of compatible detectors. Point 1 is supervised with a 2 k Ω EOL resistor.

4.4.2 Points 2 to 6

Points 2 to 6 are supervised with 1.0 k Ω resistors.

- **Open Loop:** Greater than 8.9 VDC, but less than 13.9 VDC.
- **Normal Loop:** Greater than 2.5 VDC, but less than 8.5 VDC.
- **Shorted Loop:** Greater than 0.0 VDC, but less than 2.0 VDC.

4.4.3 Point Response Time

The panel scans point sensor loops every 500 ms. A point must be faulted for two scans (1 sec.) before the panel initiates an alarm.

5.0 Telephone Connections

5.1 Phone Jack

To prevent jamming of reports, wire the RJ31X jack before the in-house phone system to support line seizure (see *Figure 7*). Line seizure provides for a temporary interruption of normal phone usage while the communicator transmits data.

After installation, confirm that the panel seizes the line, acquires dial tone, reports correctly to the receiver, and releases the phone line to the in-house phone system.

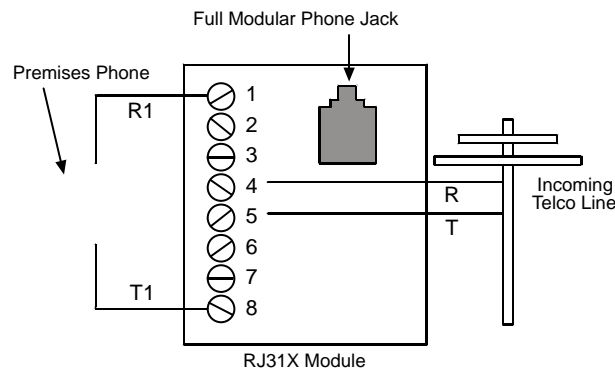

Figure 7: RJ31X Phone Jack

5.2 Phone Cord

Connect the flying leads of the D160 or D164 Phone Cord to the panel as shown in *Figure 8*. Connect the modular end to the RJ31X.

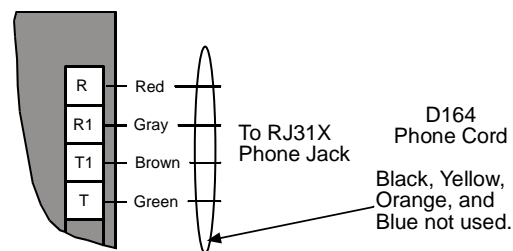

Figure 8: Phone Cord

5.3 Power Up

Connect the battery and then plug in the transformer. Leave the Standby Switch locked down for now.

5.4 Program the Panel

Use the keypad, Bosch Security Systems D5200 Programmer, or a remote programmer to program the panel. See the *D2000 Series Program Entry Guide* (P/N: 35114) for programming options and keypad programming instructions.



If you are programming from the keypad or using the D5200, make sure the Standby Switch is locked down. See Figure 10 on page 22.

If you're using the D5200, *Figure 9* on page 22 shows the location of the programming jack. See the *D5200 Programming Operation Guide* (P/N: 74-06176-000) for instructions on using the programmer.

Telephone Connections

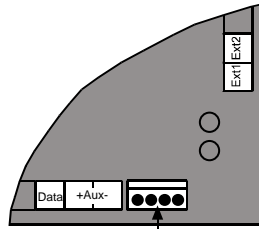

Local Programmer Connect
Lock standby switch to program.

Figure 9: Programmer Jack

5.5 Unlock the Standby Switch

When you are finished programming, move the Standby Switch to the normal position. See *Figure 10*. The panel sends a RE-BOOT report to the receiver and returns in the disarmed state. If you programmed for test reports and left the hours and minutes to next report prompts at 0 (zero), the panel sends a test report with the RE-BOOT report.

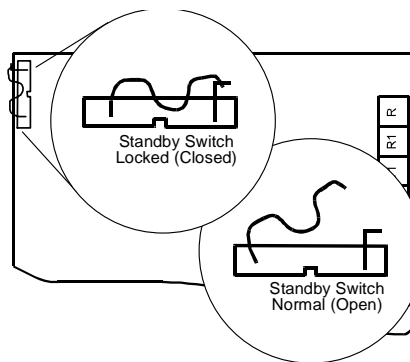

Figure 10: Standby Switch

5.5.1 RAM II Reset Bye Does Not Disarm the Panel

After you unlock the standby switch, the panel returns to a disarmed state. Using RAM II *Reset Bye*, however, does not affect the armed state of the panel.

5.6 Check for Alarm Verification



You must check the Alarm Verification box in the lower left hand corner of the Label if you programmed Point 1 for Fire with Verification (Digit 1 = 2). See POINT CODES in the D2000 Series Program Entry Guide (P/N: 35114) for more information.

5.7 Test the System

After finishing installation and programming, make a complete functional test of the system. Test the panel and all devices for proper operation. Test after you first program the panel and after any subsequent programming session.

5.7.1 Clear After Test

To clear the alarm memory and report buffer, close the Standby Switch for 2 sec., then release it. The panel returns to service in the disarmed state.

5.8 Dialing Format

You can program the panel to use DTMF or pulse dialing. See *Phone Parameters* in the *D2000 Series Program Entry Guide* (P/N: 35114).

5.9 Communication Failure

After five attempts to reach the receiver (ten attempts if two phone numbers are programmed), the panel goes into communication failure. The panel clears any reports in its phone buffer. The panel sounds a tone at the keypad indicating trouble.

Pressing the [CLEAR] key silences the tone. When communication restores (a report is acknowledged by the receiver), the keypad returns to normal operation.

5.10 Ground Start

Some telephone systems require a momentary ground input to initiate dial tone. To interface with a ground start system, connect a D133 (or D134) relay as shown in *Figure 11*. See *RELAYS Group* in the *D2000 Series Program Entry Guide* (P/N: 35114) for instructions on programming the external relay output for Ground Start.

The panel's ground terminal must be connected to an earth ground reference.



You cannot use ground start phone systems for fire or combined fire/burglary systems.

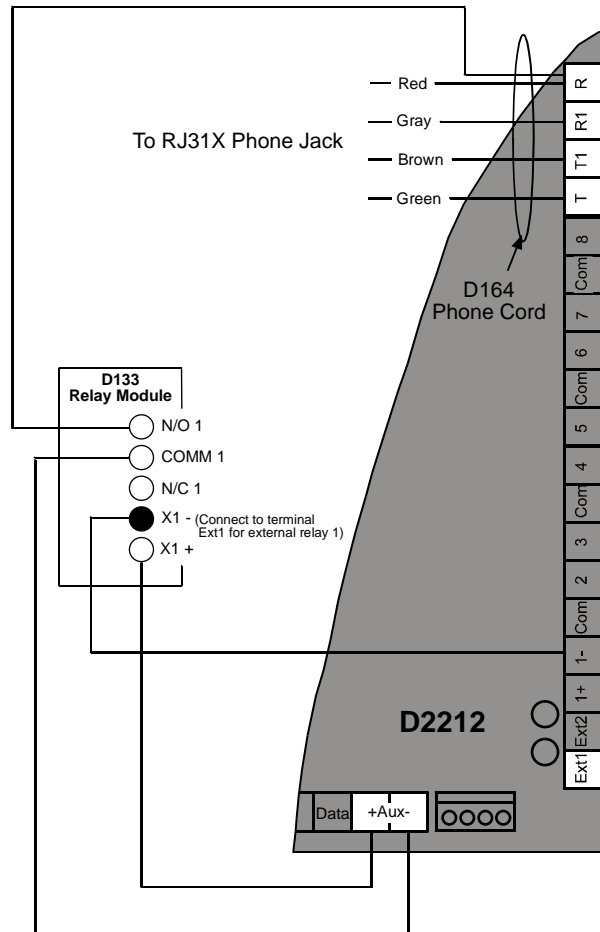

Figure 11: D133 for Ground Start

Notes:

6.0 On-Board Points

6.1 Point 1 (1+ and 1-)

Point 1 on the D2212 is a powered, supervised point.

The panel monitors the Point 1 sensor loop for normal, shorted, or open conditions. Programming determines how the panel responds to those conditions. See the *D2000 Series Program Entry Guide* (P/N: 35114).

1+ provides positive voltage to two-wire detection devices. 1-, the loop return (-), is isolated from earth ground.

The Keypad Reset function interrupts power to this sensor loop to reset smoke detectors.

Use a 2 k Ω EOL resistor for Point 1. See *Figure 12* on page 26 for point wiring.

Connecting Two-wire Smoke Detectors to Point 1: Connect up to fifteen Bosch Security Systems D262 two-wire smoke detectors to Point 1. Refer to the *D2000 Series Control/Communicator Technogram* (P/N: 35112), for a complete list of detectors compatible with the D2212. Do not mix compatible two-wire smoke detector types on this loop.

Four-wire Smoke Detectors: Connect any number (limited by available power and the Authority Having Jurisdiction) of twelve VDC four-wire smoke detectors to any supervised point. Install a suitable power supervision device according to the manufacturer's instructions. Route the power for the detectors through a D133 (or D134) Relay Module. The relay module must be connected to one of the panel's external relay outputs programmed for the reset function. See *RELAYS* in the *D2000 Program Entry Guide* (P/N: 35114) for programming instructions.

Heat Detectors and Other Dry Contact Initiating Devices: Connect any number (limited by the Authority Having Jurisdiction).

Burglary Devices: Connect any number (limited by available power) of burglary devices to any point. Do not combine fire detection and burglary devices on the same point.

6.2 Points 2 through 6

Points 2 to 6 are supervised, non-powered points.

The panel monitors sensor loops for normal, shorted, or open conditions. Programming for each point determines how the panel responds to those conditions. See the *D2000 Series Program Entry Guide* (P/N: 35114).

Terminate each sensor loop with a 1.0 k Ω EOL resistor. See *Figure 12* on page 26 for point wiring.

Four-wire Smoke Detectors: Connect any number (limited by available power and the Authority Having Jurisdiction) of twelve VDC four-wire smoke detectors to any supervised point. Install a suitable power supervision device according to the manufacturer's instructions. Route the power for the detectors through a D133 (or D134) Relay Module. The relay module must be connected to one of the panel's external relay outputs programmed for the reset function. See *RELAYS* in the *D2000 Series Program Entry Guide* (P/N: 35114) for programming instructions.

Heat Detectors and Other Dry Contact Initiating Devices: Connect any number (limited by the Authority Having Jurisdiction).

Burglary Devices: Connect any number (limited by available power) of burglary devices to any point. Do not combine fire detection and burglary devices on the same point. For UL installations, wire a sounding device (such as a buzzer) to one of the external relays (terminals Ext1 and Ext2) and to terminal +Alrm (Alarm Output). See *Figure 12* on page 26. Program the relay for Function 3 to provide annunciation of troubles for all fire points (see *RELAYS Group* in the *D2000 Series Program Entry Guide* [P/N: 35114]).

6.3 Points 7 and 8

Points 7 and 8 are non-powered points that are not supervised with an EOL resistor.

The D2212 monitors sensor loops for Points 7 and 8 for normal (closed) and open conditions. Programming determines how the panel responds to these conditions. See the *D2000 Series Program Entry Guide* (P/N: 35114). *Figure 12* shows point wiring.

For UL systems, Points 7 and 8 can only be used for tamper contacts. Tamper contacts must be installed within the protected enclosure.

On-Board Points

6.4 Point Expanders for the D2212B, Wired or RF

Point expanders are only compatible with the D2212B; they are not compatible with the D2212BE.

Points are connected by wire to D208 Point Expanders, D222 keypads and/or if RF Points are used, they transmit to an RF Receiver.

You can expand the D2212B to 24 points using wired and/or RF point expanders. On-board point numbers are fixed from Point 1 to Point 8. If you use an on-board point, you must use its point number (see the *D2000 Series Program Entry Guide* [P/N: 35114] for more information).

Points Connected to D222 Keypads: Points are supervised, non-powered points.

The panel monitors sensor loops for normal, shorted, or open conditions. Programming for each point determines how the panel responds to those conditions (see the *D2000 Series Program Entry Guide* [P/N: 35114]).

RF Points: RF Points transmit a radio frequency signal to an RF Receiver. The RF Receiver decodes the signal and sends the RF Point status to the D2212B.

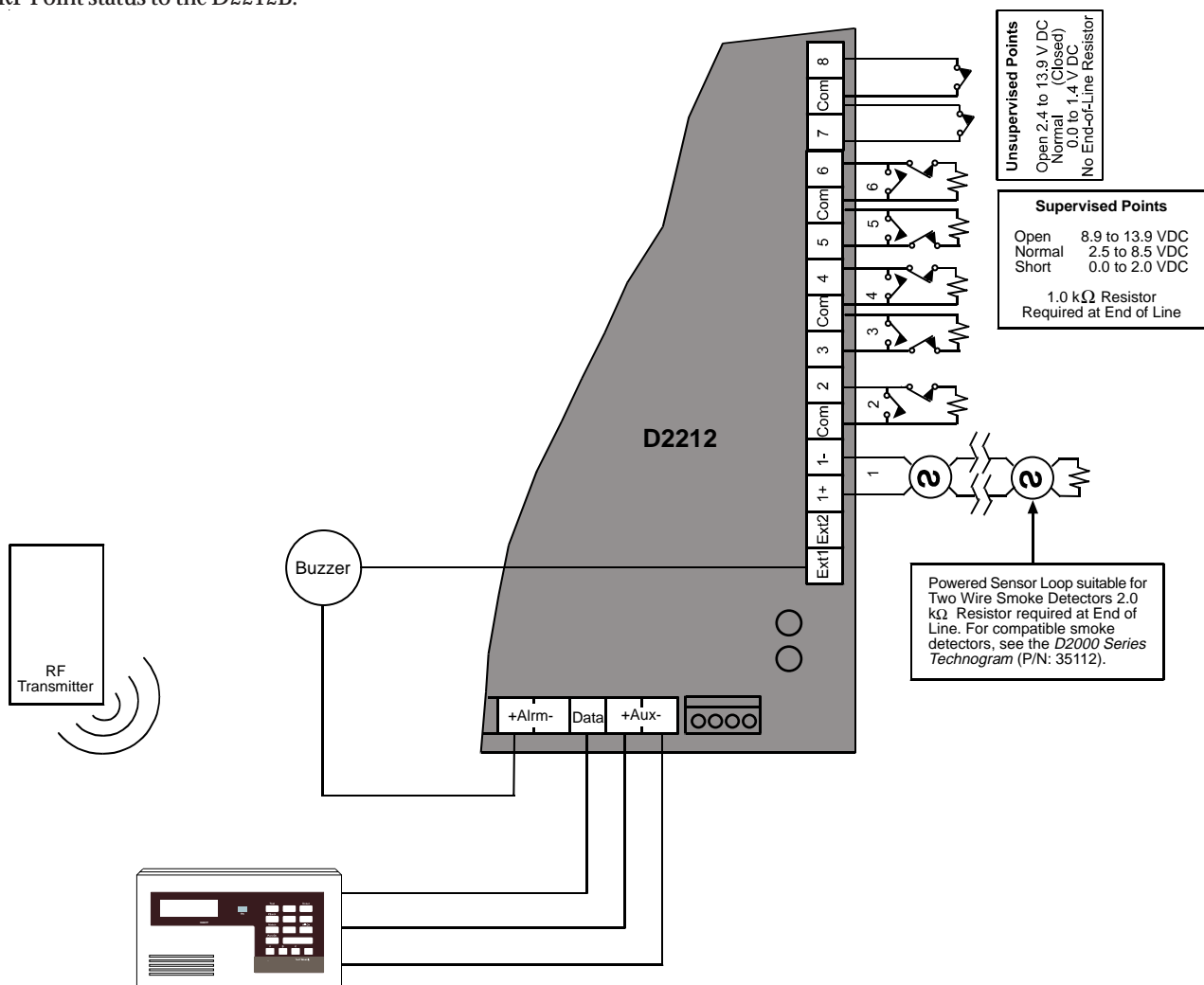

Figure 12: Points

7.0 Arming Devices

7.1 Keyswitch

7.1.1 Description

You can connect a momentary contact arming station (keyswitch) to turn the D2212 on and off. Connect the keyswitch to any point sensor loop.

You can use the external relay outputs and D133 (or D134) Relay Modules to activate arming status lights or keyswitch arming stations. See the *Relays* section in the *D2000 Series Program Entry Guide* (P/N: 35114).

7.1.2 Programming

See the *POINT CODES Group* in the *D2000 Series Program Entry Guide* (P/N: 35114) for the correct programming for points used for keyswitches.

7.1.3 Installation

Connect the EOL resistor for the point at the keyswitch so that the switch shorts the resistor when it operates. An open on the circuit produces an alarm if the area is armed and a trouble if it is disarmed (see *Figure 13*).

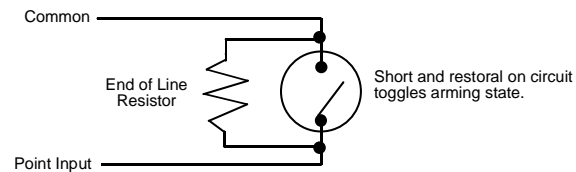

Figure 13: Keyswitch

7.1.4 Keyswitch Operation

Shorting and restoring the point sensor loop toggles the system **On** and **Off**. All faulted points are bypassed. See the *POINT CODES Group* in the *D2000 Series Program Entry Guide* (P/N: 35114).

7.1.5 Silencing the Bell

To silence the bell (stop Alarm Output) if the system is **On** (or part **On**), operate the keyswitch to turn the system **Off**. If the area is **Off**, operating the keyswitch only silences the bell. It does not turn the system **On**.

D2212B/D2212BE

Arming Devices

7.1.6 Easikey

You can use a Bosch Security Systems Easikey Access System to turn the system Off. Program the **Keyswitch** prompt to Easikey. See the *D2000 Series Program Entry Guide* (P/N: 35114) for instructions. You must use a 12 VDC option for the Easikey installation. See *Easikey Installation and Operation Instructions* (P/N : 74-07579-000). Easikey is not for use in UL installations.

Connect the Easikey door controller to the panel using a D133 Relay Module as shown in *Figure 14*. Make certain to connect the common for the Easikey's 12 VDC supply to the terminal labeled Aux- on the panel.

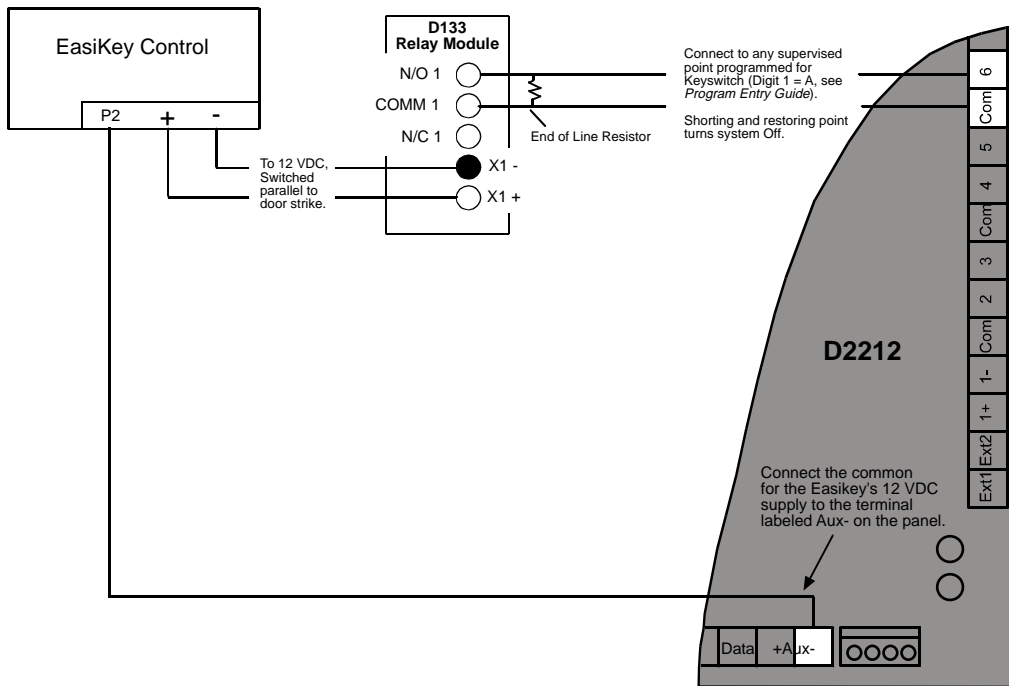

Figure 14: Easikey Wiring

Appendix A: System Wiring Diagram, Issue A

Top of Enclosure

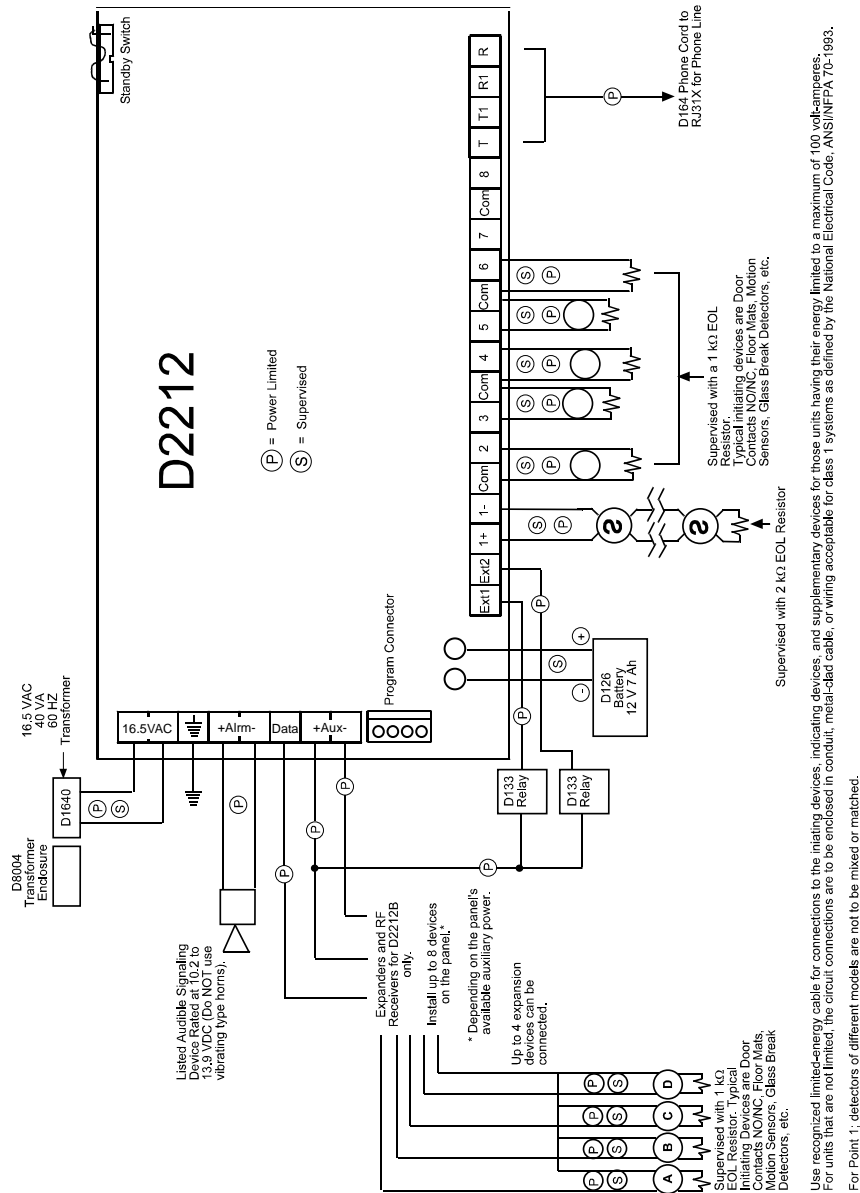

Figure 15: D2212 System Wiring Diagram, Issue A

D132A or D192C required for fire and combined fire/burglary systems: Fire installations require a D132A Smoke Detector Reversing Relay Module or a D192C NAC Supervision Module. The alarm output for fire or combined fire/burglary installations must be supervised. Use a D132A and compatible smoke detectors, or a D192C.

Appendix A

Notes:

Appendix B: Terminal Quick Reference

	Terminal	Description
16.5 VAC	16.5 VAC	D2212B: Connect D1640, 16.5 V, 40 VA Transformer for primary power. D2212BE: Connect D1625, 16.5 V, 25 VA Transformer for primary power.
	Earth Ground	Connect to earth ground. A cold water pipe or grounding rod is preferred. Do not connect to telephone or electrical ground.
+Alrm	+ Alarm Output	Continuous positive output provides 1.35 A at 10.2 to 13.9 VDC. Protected against overcurrent by self-resetting device.
Alrm-	- Alarm Output	Switched negative output for steady or pulsed (temporal code 3) alarm output.
Data	Data	Data for keypads (and point expanders on the D2212B only).
+Aux	+ Aux Power	Positive output for continuously powered devices, 1.0 A at 10.2 to 13.9 VDC for the D2212B; 500 mA for the D2212BE. Protected against overcurrent by self-resetting device.
Aux-	- Aux Power	Negative (common) for Aux Power and Relay Outputs.
Ext1	External Relay 1	Connect D133 or D134 relay for Form C Dry Contact.
Ext2	External Relay 2	Connect D133 or D134 relay for Form C Dry Contact.
1+	Positive Point 1	Positive Power for Point 1. Switched for sensor reset. Use for approved two-wire smoke or glass break detectors.
1-	Negative Point 1	Negative Power for Point 1.
Com	Common	Common for Point 2.
2	Point 2	Input for Point 2.
3	Point 3	Input for Point 3.
Com	Common	Common for Points 3 and 4.
4	Point 4	Input for Point 4.
5	Point 5	Input for Point 5.
Com	Common	Common for Points 5 and 6.
6	Point 6	Input for Point 6.
7	Point 7	Input for Point 7 (Unsupervised)
Com		Common
8		Input for Point 8 (Unsupervised)
T	Tip	Tip of incoming phone line.
T1	Tip1	Tip of phone line to premises phone.
R1	Ring1	Ring of phone line to premises phone.
R	Ring	Ring of incoming phone line.

Table 5: D2212 Terminal Reference

Notes:

Appendix C: Installation Guide for UL Applications

Introduction

Table 7 on page 37 references components evaluated and listed by UL for compatibility with the panel. These components meet the basic system requirements for the applicable standard.

Figure 15 on page 29 shows the relationship between the panel and the accessory components referred to in *Table 7*. See the installation and operation instructions for each component for detailed instructions.

Optional Compatible Equipment

You can use UL Listed components that do not require evaluation for electrical compatibility in many applications when installed in accordance with the manufacturer's instructions.

Burglary Applications

You can use UL Listed burglary alarm sensors that do not require evaluation for electrical compatibility in burglary applications. In some cases you must use a UL Listed Bosch Security Systems interface module in conjunction with the sensors. Consult the individual component specification and installation documents to determine suitability.

In burglary applications with one 7.0 Ah, 12 VDC battery, the panel supports an auxiliary output of 1.0 A and an alarm (bell) output of 1.35 A, configured as necessary. For additional loadings, refer to *Table 6* on page 35.

For commercial burglary installations, use a maximum of 45 sec. of entry delay and a maximum of 60 sec. of exit delay.

Test Weekly: UL Standard 1023 requires a weekly test. Configure the User System Test to test the battery. See *Configuration* in the *D2000 Program Entry Guide* (P/N: 35114) for instructions.

Fire Applications

You can use UL Listed fire initiating devices not requiring electrical compatibility evaluation in any application. For example: four-wire smoke detectors, heat detectors, waterflow switches, and manual pull stations are suitable fire initiating devices. Consult the individual component specification and installation documents to determine suitability.

When using four-wire smoke detectors, install a suitable power supervision unit according to the manufacturer's instructions. Use the D133 (or D134) Relay Module to provide reset capability.

In fire applications with one 7.0 Ah, 12 VDC battery, the panel supports an auxiliary output of 140 mA; it supports a total combined continuous and alarm current draw during alarm conditions of 1.0 A. For additional loadings refer to *Table 6*.

D132A or D192C required for fire and combined fire/burglary systems: Fire installations require a D132A Smoke Detector Reversing Relay Module or a D192C NAC Supervision Module. The alarm output for fire or combined fire/burglary installations must be supervised. Use a D132A and compatible smoke detectors, or a D192C.

Two-wire detectors must be electrically compatible, and must be UL Listed for use with the D2212. See the Bosch Security Systems *D2000 Series Control/Communicator Technogram* (P/N: 35112), or you may contact the detector manufacturer.

Test Weekly: Bosch Security Systems recommends testing fire and combined fire/burglary systems weekly. Configure the User System Test to test the battery. See *Configuration* in the *D2000 Program Entry Guide* (P/N: 35114) for instructions. For all burglary applications, the panel must be programmed to send a supervisory signal to the central station a minimum of once every 24 hrs. Do not set or program an automatic telephone dialer or similar device to place a call to a police station number that is not specifically assigned by that station for such service.

Sounding Device

The sounding device shall operate for at least 4 min. before an automatic cutoff for household burglary applications and at least 15 min. for commercial burglary applications.

Appendix C

Enclosures

The D2203 enclosure is suitable for household fire and burglary applications only.

Enclosure tamper protection causing an immediate alarm signal is required for all burglary applications.

Bosch Security systems offers three optional enclosures:

The D8103 enclosure is suitable for residential fire and/or burglary installations and commercial applications. See *Table 7* on page 37 for acceptable applications.

The D8109 is normally used for fire alarm applications. The D8109 is approved by the Factory Mutual, California State Fire Marshal, and the New York City Materials and Equipment Acceptance System.

The D8108A is attack resistant. It is intended primarily for UL commercial burglary and mercantile safe and vault applications requiring a local bell. You can use the D8108A in a burglary application where the D8103 or D8109 enclosure is suitable. The D8108A is approved by the Factory Mutual, California State Fire Marshal, and the New York City Materials and Equipment Acceptance System.

The D2212 control panel is suitable for Police Station connect applications, including Grade A Mercantile Premises and Grade A Mercantile Safe and Vault alarm systems. Suitable for Grade AA Mercantile Premises and Grade AA Mercantile Safe and Vault alarm systems when the D2212 DACT unit is installed in conjunction with the D8122 Derived Channel Subscriber Terminal Unit. For all Police Station applications and grades, the D8108A Attack Resistant Enclosure with a UL Listed local sounding device is required. Per UL 365, keyswitches mounted outside the protected area must employ high security locking cylinders complying with the requirements for key locks, UL 437. Tamper protection must also be provided.

The D2212 control panel is suitable for Local, Grade A Mercantile Premises and Local, Grade A Mercantile Safe and Vault alarm systems. For all Local applications and grades, the D8108A Attack Resistant Enclosure and a UL Listed Local sounding device are required. Per UL 609, when keyswitches are mounted outside the protected area, tamper protection must be provided.

The D2212 control panel is suitable for Central Station, Grade C applications. It is suitable for Central Station, Grade B applications when the D2212 DACT unit is installed with a UL Listed Local sounding device. Also suitable for Central Station Mercantile, Grade AA applications when installed with the D8122 Derived Channel Subscriber Terminal Unit.

The D2212 control panel is suitable for Proprietary Burglar Alarm, Grade C applications. Also suitable for Proprietary Burglar Alarm, Grade B applications when D2212 DACT unit is installed with a UL Listed Local sounding device. Also suitable for Proprietary Burglar Alarm, Grade AA when the D2212 DACT unit is installed with a D8122 Derived Channel Subscriber Terminal Unit.

The D2212 control panel is suitable for Household, Grade A applications.

UL Standard 681 for Installation and Classification of Mercantile and Bank Burglary Alarm systems requires foil lining of equivalent protection of the control unit enclosure. The D8108A enclosure does not have foil lining, but acceptable protection can be provided by mounting electronic vibration sensors inside the enclosure.

Proximity alarms (capacitance) cannot be used for this purpose.

Install electronic vibration sensors in the D8108A enclosure that are identical to those used to protect the safe or the vault. Sentrol 5402, Potter EVD-S, or Arrowhead S-3810 electronic vibration detection (EVD) systems which can be mounted inside the enclosure meet the requirements of UL 681. Mount the electronic vibration sensor directly inside the metal cabinet of the D8108A. **Do not** install the sensor within 1/4 in. (6 mm) of the components or traces of the printed circuit assembly.

Standby Battery Requirements

Household Burglary and Commercial Burglary

Standby battery capacity of 4 hrs. is required.

Standby Battery Calculation for Fire Alarm Applications

NFPA 72 (Chapter 2) Household Fire Warning Equipment: The NFPA (Chapter 2) Household Fire Warning Equipment Standard requires 24 hrs. of standby plus 4 min. (0.067 hr.) of alarm operation at the end of the 24 hr. period. You must use battery ampere hour (Ah) calculations to verify compliance. The formula in the next column includes a 10% contingency factor for depletion of battery capacity with age.

NFPA 72 (Chapter 2) Ampere-Hour Calculation Formula:

$$(\text{Total B} \times 24 \text{ hrs.}) + (\text{Total C} \times 0.067 \text{ hrs.}) + (10\% \text{ Contingency}) = \text{Total Ah required.}$$

Total Ah requirements must not exceed Ah capacity of batteries.

For Battery Calculations: When system is idle, running on battery only, the current draw from the battery is 125 mA. When the system is in communication, running on battery only, and set for pulse dialing, the current draw from the battery is 190 mA.

All currents are in milliamperes (1 ampere = 1000 milliamperes)							
Model Number	Number Used	AC Power ON <u>Normal Current</u>		AC Power OFF <u>Minimum Current</u>		In Alarm <u>Maximum Current</u>	
		Each Unit	Total	Each Unit	Total	Each Unit	Total
D2212B	1	125	125	125	125	190	315
D202A	_____	45	_____	45	_____	125	_____
D220A	_____	30	_____	30	_____	125	_____
D222	_____	30	_____	30	_____	140	_____
D223	_____	30	_____	30	_____	140	_____
D208RF	_____	50	_____	50	_____	50	_____
D216RF	_____	50	_____	50	_____	50	_____
_____	_____	_____	_____	_____	_____	_____	_____
_____	_____	_____	_____	_____	_____	_____	_____
_____	_____	_____	_____	_____	_____	_____	_____
_____	_____	_____	_____	_____	_____	_____	_____
		Total A* =	_____	Total B =	_____	Total C** =	_____

* If Total A exceeds 1.0A (140 mA for fire and combined fire/burglary systems, a stand-alone power supply is required to provide additional current.
 ** If Total C exceeds 860 mA, for fire systems, a stand-alone power supply is required to provide additional current.

Table 6: Current Rating Chart for Standby Battery Calculations

Notes:

Appendix D: System Chart

	Household Burglary (Grade A)	Household Fire	Household Fire/Burglary Combined	Central Station Burglary (Grade C)	Police Connected Burglary	Local Burglary	Proprietary Burglary	Local Fire/Burglary Combined	Local Fire	Local and Central Station Fire Combined	Local and Central Station Fire/Burglary (Grade C)	Central Station Fire/Burglary (Grade C)	Central Station Fire	Electrically Actuated Transmitter
NFPA Standard		72	72					D2412 not listed for these applications						
Minimum Hours of Standby Battery	4	24 + 4 min. alarm	24 + 4 min. alarm	4	4	4	4	Key						
								No	=	Not acceptable for this application.				
D2203/D2803 Enclosure	Included with panel				No	No	No	Req.	=	Required for this application.				
D8103 Enclosure	Optional			Choose One	No	No	No	Opt.	=	Optional for this application.				
D8108A Enclosure	Optional				Req.	Req.	Req.	1+	=	One or more required for this application. Consult the appropriate standard.				
D8109 Enclosure	Optional				No	No	No	2+	=	Two or more required for this application. Consult the appropriate standard.				
D126 Battery	1	1	1	1	1	1	1	1•	=	At least one detector required. You can substitute other two-wire detectors listed for use with the D2012. You could use the D262 with the D270 four-wire base or other manufacturer's four-wire detectors. You must use a listed power supervision relay with four-wire detectors.				
D127 Reversing Relay	Opt.	No	Opt.	Opt.	Opt.	Opt.	Opt.							
D132A Smoke Detector Reversing Relay Module	Required if D192C is not used. Use the D132A with compatible smoke detectors.													
D164 Telephone Cord	Required to connect panel to RJ31X Telco Block													
D192C NAC Supervision Module	Required if D132A and compatible smoke detectors are not used.							◆	=	Listed bell (siren) housing required for burglary alarm, bell or siren.				
D202A, D220A, D222, D223 Command Center	1+	1+	1+	1+	1+	1+	1+		=	(Empty box) Not used for this application.				
D262 Smoke Detector Head D261 Base		1•	1•						=	D101 required for D8130 enclosure.				
D282THS Smoke Detector with Sounder	Use with D132A													
D431, D435, D438, D440, D442, D448 Indicating Device	1+	1+	1+	Opt.	◆	◆	◆							
D1640 Transformer	Required for all applications													
D8004 Transformer Enclosure	Opt.	Opt.	Opt.	Opt.	Opt.	Opt.								
D8122 Derived Channel S.T.U.	Optional, contact TelCo for availability of derived channel service													
D8130 Release Module	Optional													

Table 7: System Chart

Appendix D

Notes:

Index

A

Approvals	
Burglary	8
Fire	8
Arming Devices	27
Keyswitch	27
Auxiliary Power	18

B

Battery	14
Discharge Cycle	20
Recharge Cycle	20
Replacement	19
Supervision	19

C

Canadian Compliance	10
---------------------------	----

D

Dialing Format	22
----------------------	----

E

EMI	16
External Relays	18

F

FCC Notice	
Part 15	9
Part 68	9
FCC Registration Number	9

K

Keypads	17
D202A Keypad	13
D205 Keypad	13
D206 Keypad	13
D220A Keypad	14
D222 Keypad	14
D223 Keypad	14

L

Listings	
Burglary	8
Fire	8

O

On-Board Points	25
-----------------------	----

P

Power	
Primary	19
Secondary	19
Primary Power	19

R

Ringer Equivalence	9
--------------------------	---

S

Secondary Power	19
Service Center	9

T

Telephone	21
Phone Cord	21
Phone Jack	21

U

UL Applications	33
-----------------------	----

W

Wiring	
EMI	16
Wire Length	15

