

Intelligent Video Analytics Pro

MVC-IVA-LPR | MVC-IVA-LPRX | MVC-IVA-MMR | MVC-IVA-DGS

Table of contents

1	Use latest software	4
2	Introduction	5
3	Installation considerations	6
3.1	Positioning	6
3.2	Number of lanes	9
3.3	Field of view	10
3.4	Parameters	12
4	Connection	13
4.1	Starting via the web browser	13
4.2	Starting via the Configuration Manager	13
5	Configuration	14
5.1	License plate format	14
5.2	Detection area	14
5.3	Lanes and detections	14

1 Use latest software

Before using the software application for the first time, make sure that you are running the most current software release. For consistent functionality, compatibility, performance, and security, regularly update the software throughout the operational life of the software application. Follow the instructions in the product documentation regarding software installation and updates.

The following links provide more information:

- General information: <https://www.boschsecurity.com/xc/en/support/product-security/>
- Security advisories, that is a list of identified vulnerabilities and proposed solutions: <https://www.boschsecurity.com/xc/en/support/product-security/security-advisories.html>

Bosch assumes no liability whatsoever for any damage caused by operating its products with outdated software components.

2 Introduction

Intelligent Video Analytics (IVA) Pro licenses

IVA Pro License Plate, IVA Pro Vehicle Make Model and IVA Pro Dangerous Good Signs are a deep neural network based video analytics that detects and reads license plates on moving vehicles (car, van, bus, truck, motorbike). The license plate are transmitted in real time via different protocols ensuring easy integration.

To access and start the video analysis use a web browser once the camera connection is established or the Configuration Manager program. For more information on the access and start of the applications, refer to *Connection, page 13*.

More information

For more information, software downloads, and documentation, go to www.boschsecurity.com and the corresponding product page.

Compatibility

For information on supported cameras, refer to the Bosch Video Product Selector: www.videoselector.boschsecurity.com

Refer to

- *Connection, page 13*
- *Configuration, page 14*

3 Installation considerations

The quality of vehicle license plate detection and recognition, vehicle make and model identification, and dangerous goods sign detection depends on the location and position of the camera installation, and the camera configuration settings. This chapter describes the requirements to achieve the best results.

After modifying or adjusting the installation position or camera settings, you must reset the calibration of the LPR in the web browser of the camera view or in the Configuration Manager.

To reset the calibration via the web browser:

1. Open the web browser view of the device.
2. Click **Configuration > Alarm > LPR**.
3. Click **Reset Calibration**.

To reset the calibration via the Configuration Manager:

1. Start Configuration Manager.
2. In the **View** area, click the **VCA** tab.
3. Select **License Plate Recognition** tab.
4. Click **Reset Calibration**.

For more information on connecting to the application, refer to *Connection*, page 13.

3.1 Positioning

Choose the position of the camera so that it is possible to observe the movement of the license plate during the vehicle passage.

Height [m]

The camera should be installed at a height slightly above the roof of the vehicle.

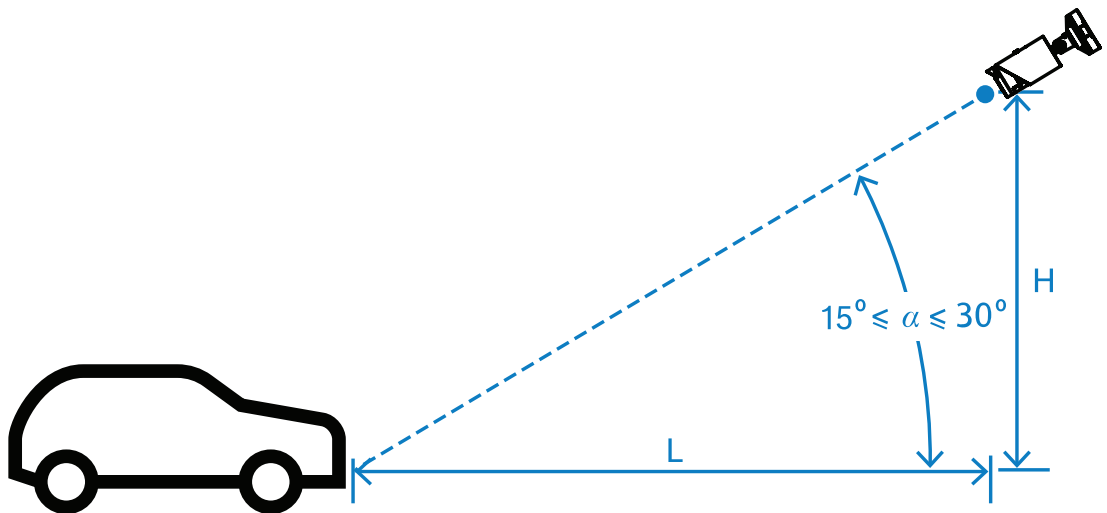

The installation height H depends on the availability of mounting constructions, and in practice this means:

$$2.0 \text{ m} \leq H \leq 10.0 \text{ m}$$

**Notice!**

Low elevation installation

Installing the camera at a low elevation, such as at the level of the vehicle's roof, may cause the camera to be blinded at night by the vehicle headlights. This positioning could prevent the camera from accurately analyzing the movement and detection of the vehicle.

Distance [m]

The distance from the camera to the detection line is directly derived from the height of the installation H . The optimal distance L is the distance for which the angle α between the optical axis of the camera and the plane of the road equals 22.5° . For example, for the installing height $H = 6$ m can be calculated:

$$L = H \cdot \cot(\alpha) = 6 \cdot \cot(22.5^\circ) \approx 6 \cdot 2.4 = 14.4 \text{ m}$$

For more information on setting the detection line, refer to *Detection line*, page 10.

The table that follows indicates the ideal distance in relation to the camera height. For reliable recognition, the focal length of the camera lens should be sufficient to reach the required pixels on target.

For more information on the character size for the license plate, refer to *Character size*, page 11.

Height (H) m(ft)	Optimal Distance (L) m(ft)
2.0 m (6 ft)	9.0 m (29.5 ft)
2.5 m (8.2 ft)	14.4 m (47.2 ft)
3.0 m (9.8 ft)	18.0 m (59.1 ft)
3.5 m (11.5 ft)	21.6 m (70.9 ft)
4.0 m (13.1 ft)	24.9 m (81.7 ft)
4.5 m (14.8 ft)	28.8 m (94.5 ft)
5.0 m (16.4 ft)	32.4 m (106.3 ft)
5.5 m (18.0 ft)	36.0 m (118.1 ft)
6.0 m (19.7 ft)	39.6 m (129.9 ft)
6.5 m (21.3 ft)	43.2 m (141.7 ft)
7.0 m (23.0 ft)	46.8 m (153.5 ft)
7.5 m (24.6 ft)	50.4 m (165.4 ft)
8.0 m (26.2 ft)	54.0 m (177.2 ft)
8.5 m (27.9 ft)	57.6 m (189.0 ft)
9.0 m (29.5 ft)	61.2 m (200.8 ft)
9.5 m (31.1 ft)	64.8 m (212.6 ft)
10.0 m (32.8 ft)	68.4 m (224.4 ft)

The angle α can be adjusted to suit the conditions of a particular installation solution, but it should be within the range:

$$15^\circ \leq \alpha \leq 30^\circ$$

**Notice!**

If the angle α is too small ($< 15^\circ$) then there may be an overshadowing of vehicles following one another. If the angle α is too large ($> 30^\circ$) the geometry of the number plate will be disturbed. At night, the light from the IR illuminator will not reflect properly, making vehicle detection weaker.

Angle

The camera can be installed within the lane or at the lane's edge.

It is important that the horizontal angle β between the optical axis of the camera and the axis of the road is not greater than 30° :

$$-30^\circ \leq \beta \leq +30^\circ$$

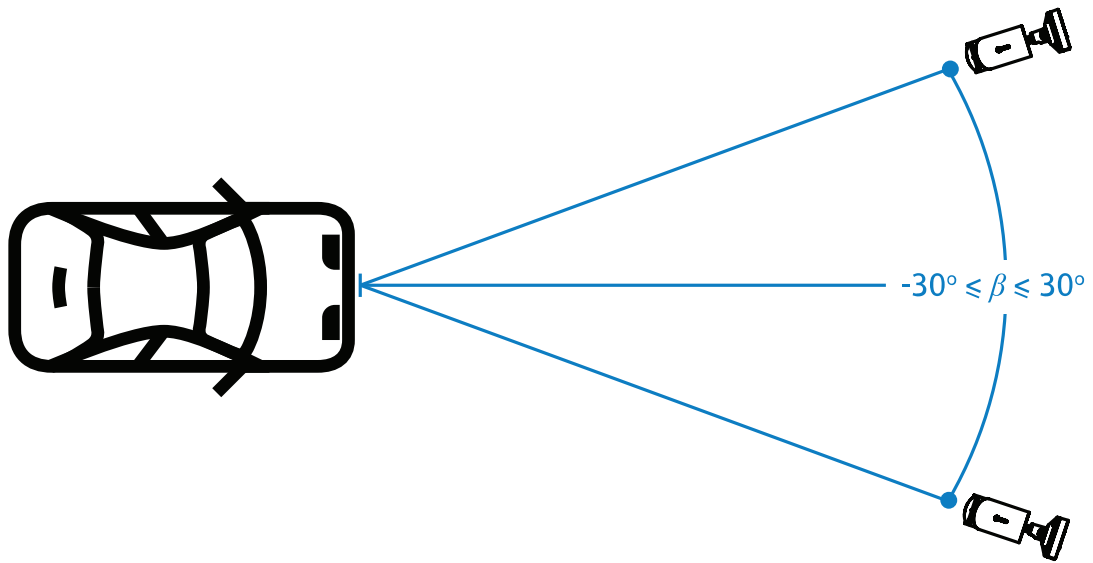
**Notice!**

Ensure that the value β remains within the specified range to avoid distortion. Exceeding the range may reduce image detection quality, causing narrow characters on the license plate or inadequate IR illumination due to lack of reflected light.

Tilt angle [°]

When installing the camera, ensure proper leveling by aligning the longer edge of the license plate parallel to the camera's horizontal field of view.

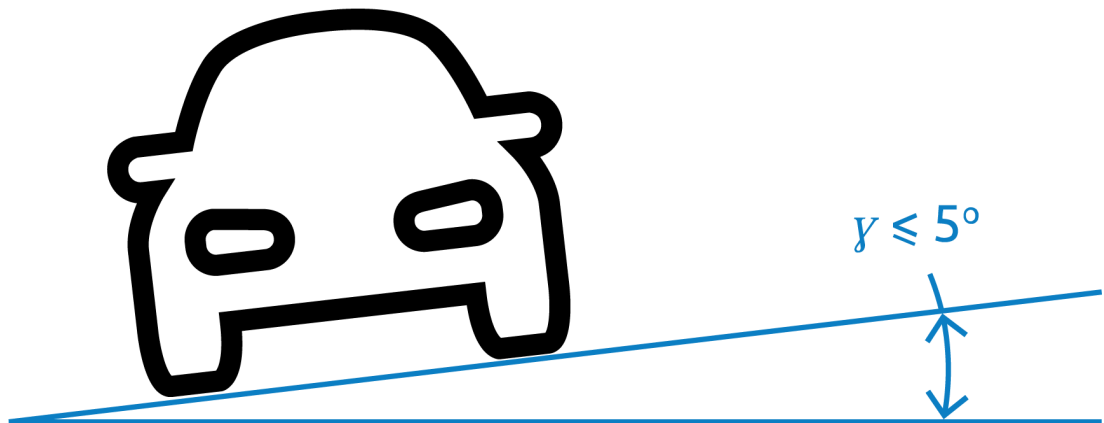

For best performance the tilt angle should be within the range of $-5^\circ \leq \gamma \leq +5^\circ$, but must be within the range $-30^\circ \leq \gamma \leq +30^\circ$.

3.2 Number of lanes

Choose the position of the camera relative to the lane considering the number of lanes the detection of the vehicle will cover.

1-Lane

When a camera covers one lane, you can install within the lane or at the edge of the lane.

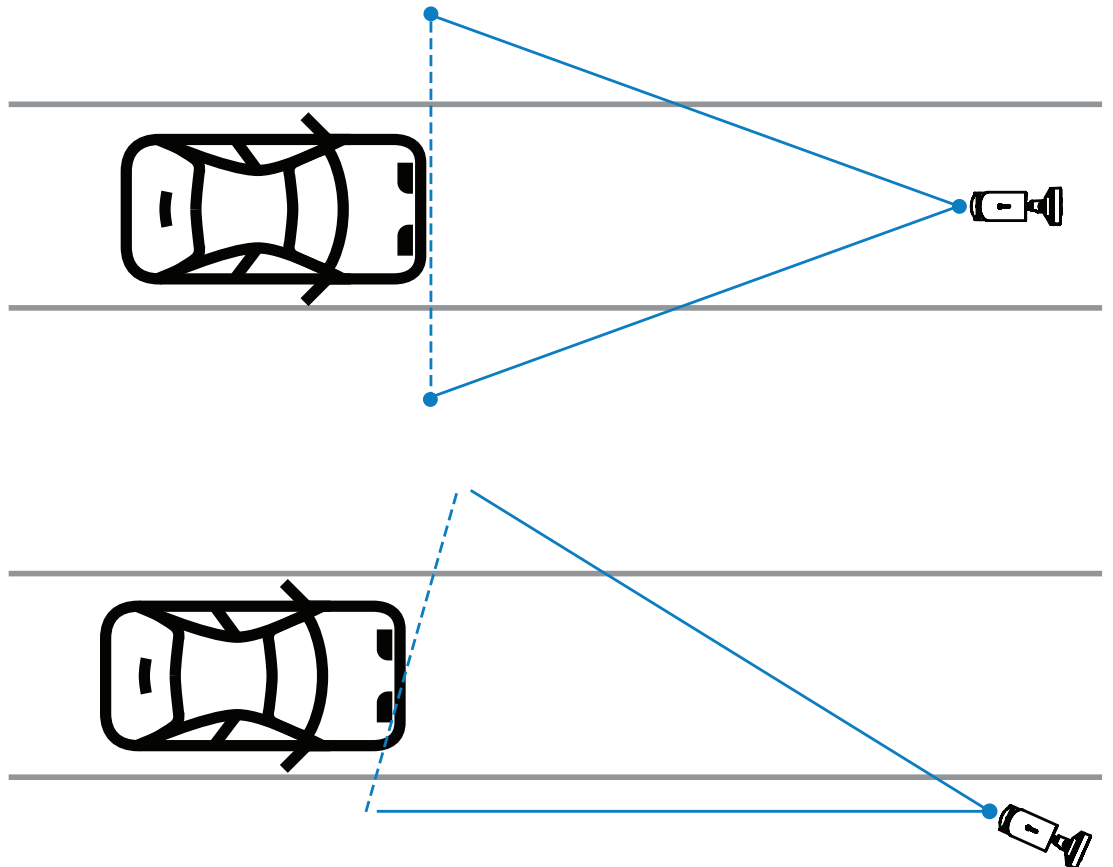

The field of view should be at least twice as wide as the lane to ensure that the front of the vehicle is visible.

2-Lanes

For two-lane detection, install the camera on the line separating the lanes.

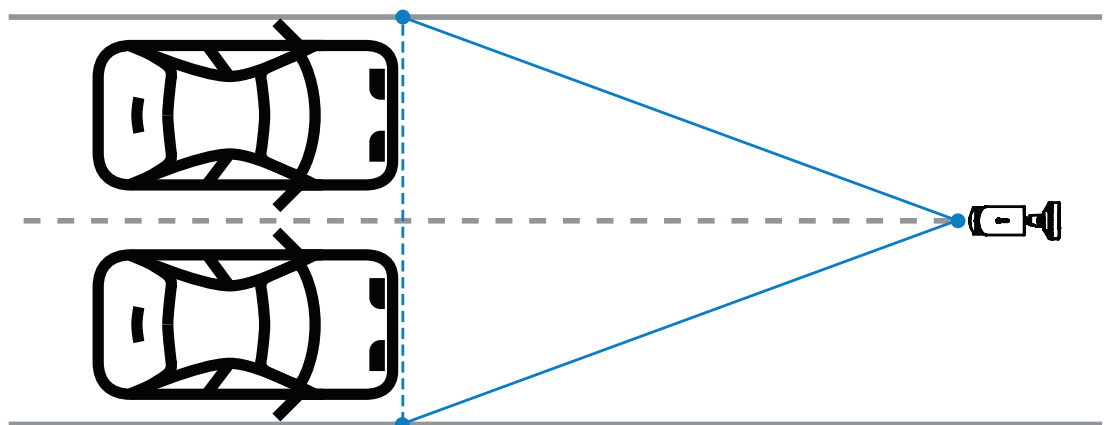

**Notice!**

Avoid install the camera at the edge of the road as it can cause to overshadow the vehicles and reduce or prevent the visibility of the license plate. If it is technically no other possibility, it is better to install the camera at the edge of the faster lane, where less trucks are driving.

3.3**Field of view****Detection line**

The detection line is a virtual horizontal line in the field of view that indicates where the expected detection of the license plate should occur. Usually it is the line in the middle of the field-of-view height.

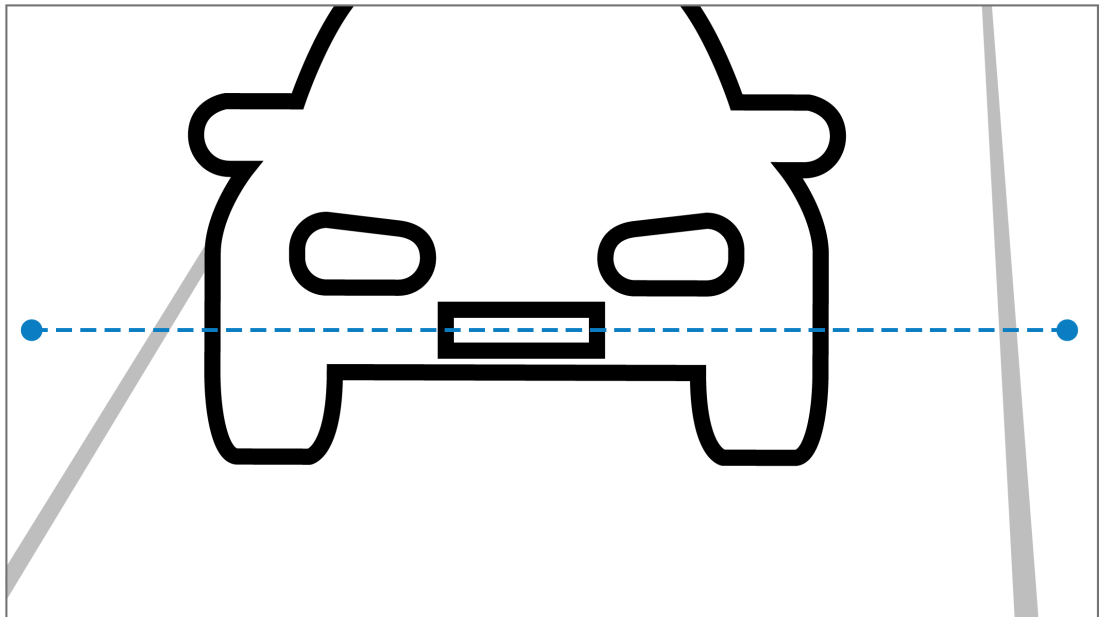
**License plate on the detection line****Field width**

The setting of the field of view width depends on the number of observed lanes. Usually, the optimal width is 6 m at the height of the detection line.

For more information on choosing the camera mounting based on number of lanes, refer to *Number of lanes*, page 9.

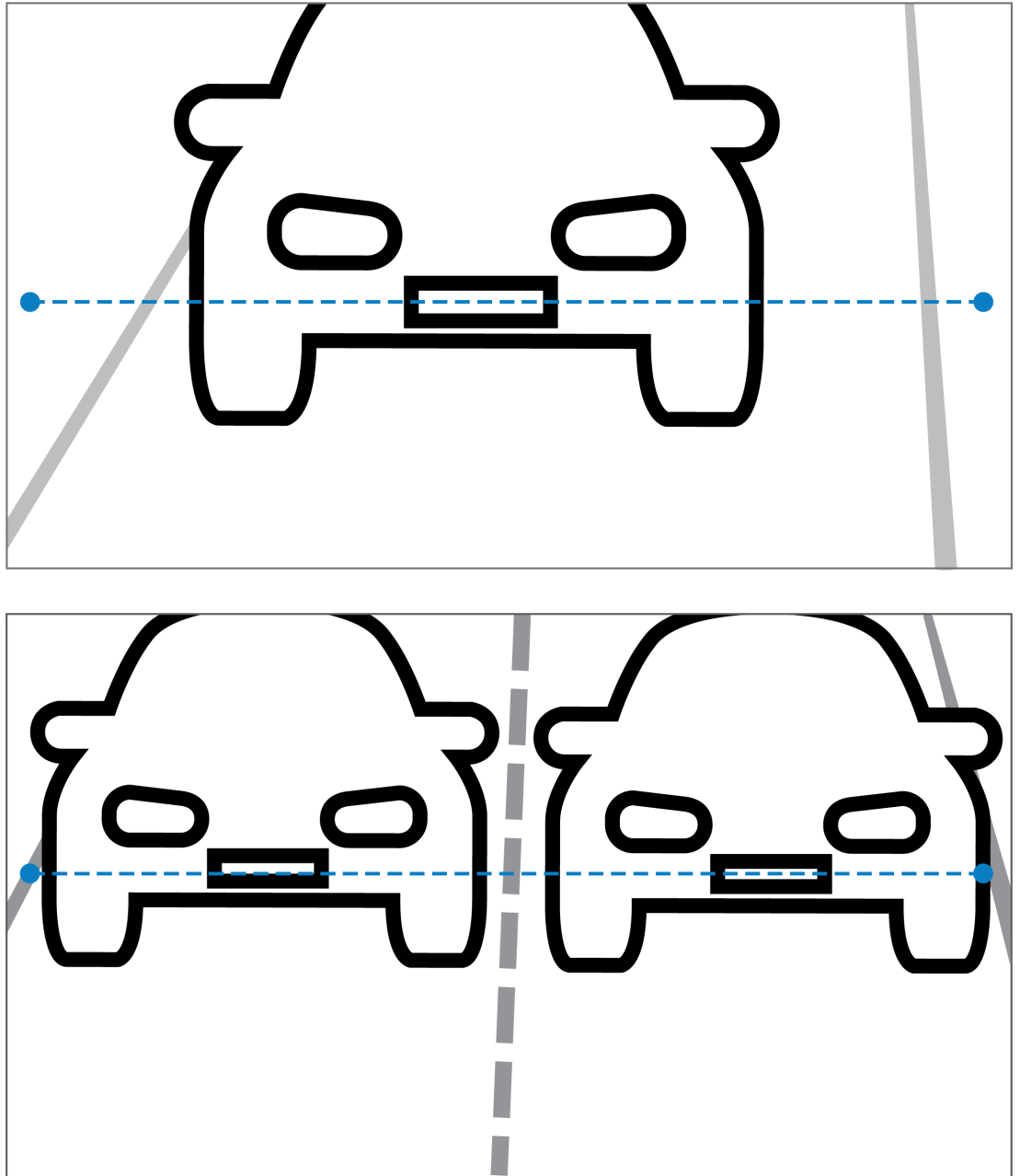
**Field of View**

The setting of the field of view depends on two factors:

- Minimum character height
- Maximum vehicle speed

The IVA Pro License Plate requires that for a given vehicle passage in the field of view, the license plate is visible at least twice. This means that the field of view for height must cover a large enough road section to make the number plate visible twice at maximum speed, considering a frame rate of 12.5 frames per second.

In this case, the user can modify the zoom and angle of the camera.

Character size

The recommended character height for the license plate on the detection line is for $S = 16$ pixels.

**Notice!**

The required height refers to the image processed by the application, not the native image of the camera. Currently, the image is resampled to a resolution of 1280x720 for the 2MP, 4MP and 5MP cameras and 1024x576 pixels for the 8MP cameras.

A character height of 16 pixels in the processed image is considered the optimal pixel density. The application can still recognize plates with smaller character heights, such as 10-12 pixels per character in non-noisy images.

3.4

Parameters

LPR Scene Mode

For best performance, it is recommended to select the LPR scene mode of the camera 24 hours a day.

Exposure

The following Exposure settings are recommended:

- Maximum shutter < 1/750 s for parking applications
- Maximum shutter < 1/1750 s for other applications

**Notice!**

Allow the camera to modify automatically the exposure time according to the lighting conditions.

In low-light or night conditions, note the following information:

- To identify the vehicle's class, make, or model from the image, the front or rear of the vehicle must be visible.
- At night, the camera prioritizes to capture the license plate, using IR illumination that reflects the license plates. In this situation it can happen that only the license plate is visible, not the rest of the vehicle.
- If visibility of these details is necessary, additional illumination is required.

4 Connection

**Notice!**

Make sure your camera have an activated license for IVA Pro License Plate, IVA Pro Vehicle Make Model, IVA Pro Dangerous Good Signs or IVA Pro License Plate plus Make Model.

4.1 Starting via the web browser

A computer with a web browser (Google Chrome, Microsoft Edge, or Mozilla Firefox) is used to receive live images, control the unit, and replay stored sequences. The unit is configured over the network using the browser.

To start the license using the web browser view:

1. Open the web browser view of the device. To do this, in the address bar of the web browser enter `http://<IP address of the device>`.
2. Click **Configuration > Alarm > VCA**.
3. In **VCA configuration**, select **LPR Mode** from the drop down menu.
4. Go to the **LPR** page.

The camera image and the **Lanes and detections** summary details are visible here.

**Notice!**

The system requirements and operation of the web browser view are described in the documentation of the corresponding camera.

4.2 Starting via the Configuration Manager

Configuration Manager can be installed on any Windows PC that communicates with the respective device over a network. Configuration Manager needs no license and no additional programs are required to analyze live images.

**Notice!**

The system requirements and operation of Configuration Manager are described in the Configuration Manager manual.

To start VCA:

1. Start Configuration Manager.
2. In the toolbar, click the **My Devices** tab, then select the device for which you wish to configure VCA.
3. In the **View** area, click the **VCA** tab.
The VCA start page is displayed and the camera image appears to the right.
4. Select **License Plate Recognition** tab.

The camera image shows the detection area that is delimited with a green line.

**Notice!**

If the VCA configuration of this camera is in use, no other users can configure VCA of this camera at the same time. Only the first user is able to do this. Other users receive a message that configuration is not possible.

5 Configuration

5.1 License plate format

The vehicles license plates are different from different regions. To retrieve the correct format and details from the vehicles detected, you must select the applicable country of the license plate:

1. Click **Configuration > Alarm > LPR**.
2. On the top right, in the **License plate format** select the region applicable for the intended from the drop down menu.
3. Click **Reset calibration** button.

Note: After selecting or changing to a new region you must reset the calibration.

5.2 Detection area

The default detection area covers the full captured video. Adjust the detection area to include only the area of interest. Additionally, the license plate should be visible at least twice within the detection area.

It is important to configure a balanced detection area.

To configure the detection area:

1. Click and drag the corner to adjust the detection area.
2. Click **Save**.

5.3 Lanes and detections

Lanes

It is possible to configure maximum of two lanes in the detection area. The page shows one lane added by default.

To add a lane:

- ▶ Click the **Add lane** button.
The button disappears once the two lanes are added.

To remove a lane:

1. Select the lane you want to remove.
2. Click on **Remove lane**.

To configure the lane or lanes:

1. Click on **Lane 1** or **Lane 2** button.
2. In the **Configure lane** window, if desired edit the name identification in **Lane name** field.
3. Choose from the **Lane direction** drop down menu, the direction **Up** or **Down**.
The direction up indicates the outgoing traffic flow and the direction down indicates the ongoing traffic flow.
4. Click **Ok** to confirm the selection or **Cancel** to go back.
5. Click and drag the endpoints to adjust the size of the lane.
6. Click and drag the line to choose the position within the detection area.
7. Click **Save**.

Detections

The section **Lanes and detections** shows a summary of the last twenty vehicles detected.

The following columns are available:

- Time - Date and timestamp
- Plate image - Picture of the full license plate
- License plate - The license plate alphanumeric characters

- Country - Country of origin of the license plate
 - Hazard Identification number - only if the IVA Pro Dangerous Good Signs license is activated
1. Click **Show more** to see more details of the detected vehicle.
 2. Click **Close** to go back to the previous page.

The table indicates what details are available depending on the type of license:

	MVC-IVA-LPR IVA Pro License Plate	MVC-IVA-MMR IVA Pro Vehicle Make Model	MVC-IVA-LPRX IVA Pro License Plate plus Make Model	MVC-IVA-DGS IVA Pro Dangerous Good Signs
Picture of the vehicle*	✓	✓	✓	✓
Plate image*	✓	✓	✓	✓
Timestamp	✓	✓	✓	✓
License plate	✓	x	✓	x
Country	✓	x	✓	x
Region	✓	x	✓	x
Vehicle class	x	✓	✓	x
Vehicle maker	x	✓	✓	x
Vehicle model	x	✓	✓	x
Vehicle color*	x	✓	✓	x
Direction in relation to the lane*	✓	x	✓	✓
Hazard Identification number	x	x	x	✓
* Currently not integrated in the ONVIF and Bosch Metadata system.				

Bosch Security Systems B.V.

Torenallee 49

5617 BA Eindhoven

Netherlands

www.boschsecurity.com

© Bosch Security Systems B.V., 2024

Building solutions for a better life

202411191058