



BOSCH

INSTALLATION INSTRUCTIONS: FCD-350 FOUR-WIRE DUCT SMOKE DETECTOR

These are Installation Instructions (DWG.# HA-06-445) for the FCD-350 Duct Detector configured as follows:
FCD-350 Duct Housing with the FCD-350-DH Conventional Photoelectric Smoke Detector

I. LOCATION REQUIREMENTS

To prevent false alarms the detectors should not be mounted in areas of extreme high or low temperatures, in areas where high humidity exist, or in areas where duct air may contain gases or excess dust. The duct detector should, when possible, be located a minimum of six duct widths downstream from a source of turbulence (bends, inlets, or deflection plates). At these locations, air flow is less turbulent and the air/smoke mixture should be more homogenous. Refer to NFPA 90A, 72, and 101 for more information. See Figure 1.

Exception: Where it is physically impossible to locate the duct detector accordingly, the duct detector can be positioned closer than six duct widths, but as far as possible from inlets, bends, or deflection plates.

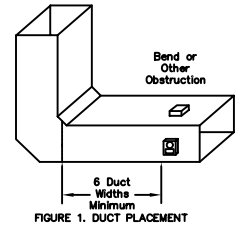

II. MOUNTING THE DETECTOR

A. DUCT PREPARATION

1. Remove paper backing from mounting template (packaged in installation kit) and affix to duct at desired location on the side or top of duct.
2. Using template as a guide, drill 4 mounting holes (3/32" diameter) for duct mounting screws (4 #12 x 1/2" sheet metal screws packaged in installation kit). Drill or punch holes for sampling tubes in air ducts (1-3/8" diameter), using template as a guide. Clean all holes.

B. VERIFY AIR FLOW AND DIRECTION

The Duct Detectors are designed for use in ducts where the air velocities are from 1,000 to 4,000 feet per minute. See Figure 2 for sampling tube orientation to air flow direction.

C. SAMPLING TUBE ASSEMBLY (See Figure 2)

The sampling tubes may be ordered to a desired length or ordered in one of 3 standard lengths and cut per requirements. The intake sampling tube consists of a piece of steel piping with a series of holes drilled the entire length of the tube and should extend the entire width of the duct. The holes must be facing into the air flow (see Figure 2). The exhaust tube consists of a piece of steel piping approximately 7-1/2" long.

INTAKE SAMPLING TUBES STANDARD LENGTHS: FAA-325-2.5 For duct widths of 1.0' to 2.5'
FAA-325-5 For duct widths of 2.5' to 5.0'
FAA-325-10 For duct widths of 5.0' to 10.0'

1. Cut the intake sampling tube to the desired length.
2. Firmly insert the stopper (packaged in installation kit) in the end of the INTAKE sampling tube.

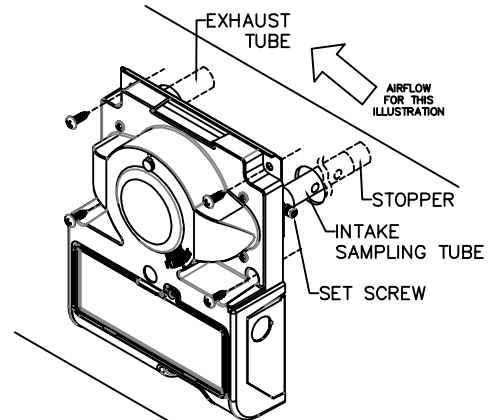

FIGURE 2. FCD-350 MOUNTING

D. MOUNT SAMPLING TUBES (See Figure 2)

1. Sampling tube connectors are equipped with set screws, which allow the tubes to be mounted only in directions shown in Figure 2. Establish proper orientation considering airflow direction.
2. Insert intake and exhaust tubes into connectors, align set screw to set screw hole in tubes and tighten firmly.

E. MOUNT THE DUCT HOUSING (See Figure 1B & 2)

Move duct housing/sampling tube assembly to desired location. Use 4 mounting screws (4 #12 x 3/4") sheet metal screws, packaged in installation kit) to secure the housing to the air duct.

F. COVER REMOVAL (See Figure 1B & 2)

Remove the access hatch cover by removing tamper screw if installed, and depressing the tab. Unscrew the 4 screws on the top of the duct housing, screws are captive in the housing. Push the catch inside the access cover down to release the cover.

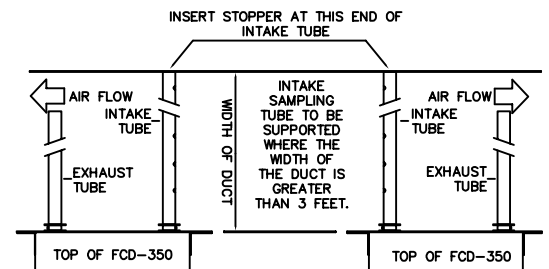

FIGURE 3. SAMPLING TUBE ORIENTATION

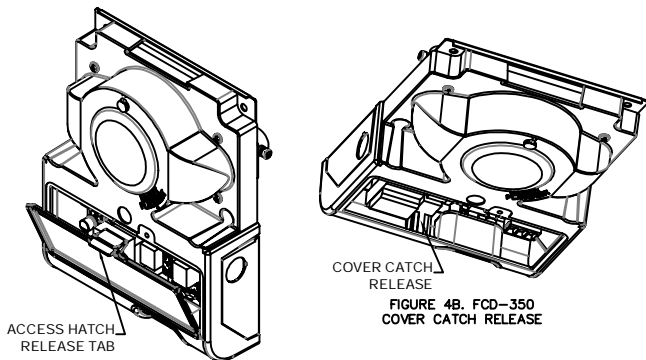

FIGURE 4A. FCD-350 ACCESS HATCH COVER REMOVAL

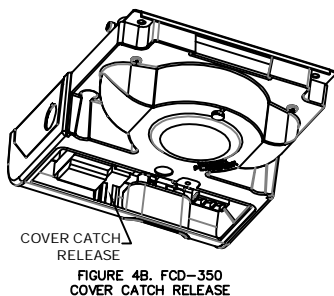

FIGURE 4B. FCD-350 COVER CATCH RELEASE

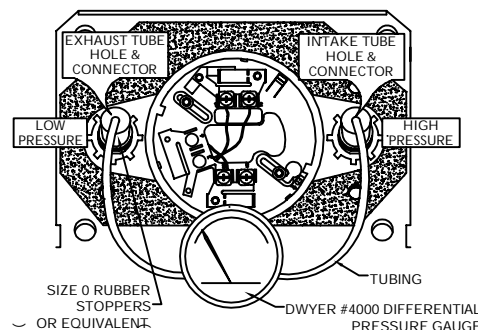

FIGURE 5. AIR SAMPLING VERIFICATION

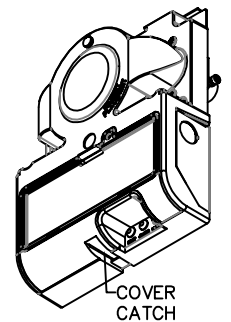

FIGURE 6. FCD-350 COVER ATTACHMENT

G. VERIFY AIR SAMPLING (See Figure 3)

To verify proper sampling of air, use a Dwyer Model 4000 differential pressure gauge (or equivalent). See Figure 5 for gauge connections (FCD-350-DH detector not shown). The pressure differential between input sampling tube and exhaust tube should be greater than 0.01" of water and less than 1.2" of water. Return cover and tighten captive screws. Ensure the catch is engaged by pushing from the outside. There should be a solid green pilot indication. Indication is independent of seal integrity.

III. ELECTRICAL INSTALLATION

A. GENERAL INFORMATION

Wiring must conform to applicable local codes, ordinances and regulations covering these types of devices. Wire the detectors according to the engineering drawings for the particular job requirements. These detectors are not intended for open area protection, nor should they be used for open air protection. Refer to NFPA 90A and NFPA 72 for general and additional information on Duct Smoke Detectors concerning operation and installation. Terminals are suitable for up to #14 gauge wire.

B. DETECTOR WIRING

With power source de-energized, wire all connections per instructions on pages 2-3. The wiring access hatch cover can be stored at the top of the unit. Return cover before restoring power.

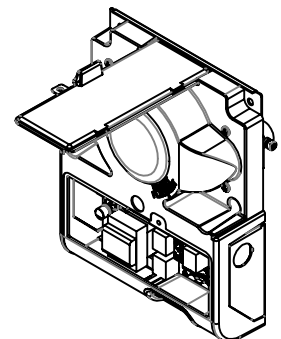
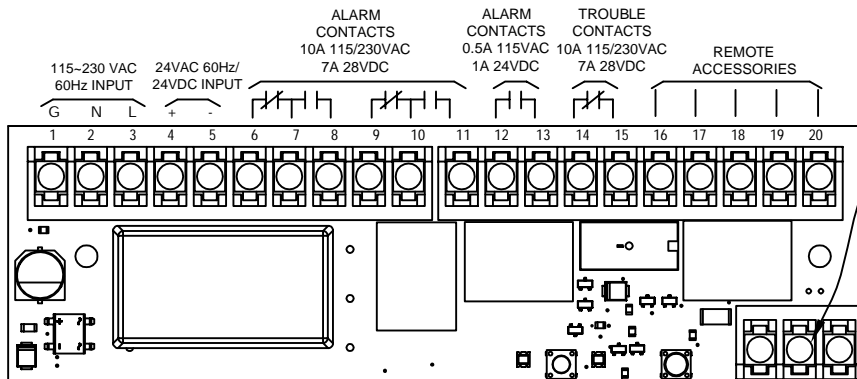

FIGURE 7. FCD-350 ACCESS HATCH COVER TEMPORARY STORAGE

Bosch Security Systems B.V.
Torenallee 49
5617 BA Eindhoven
Netherlands

FCD-350 SPECIFICATIONS	
Contact Ratings	See Wiring Diagram below
Input Voltage / Current (includes FCD-350-DH, and Remote Accessories)	Alarm 24VDC 78mA 24VAC 370mA 115AC 48mA 230VAC 31mA Normal Standby 24VDC 20mA 24VAC 263mA 115AC 15mA 230VAC 10mA
Operating Temperature Range	Inside Duct 0°C (32°F) ~ 38°C (100°F) Housing Ambient 0°C (32°F) ~ 49°C (120°F)
Air Velocity	1,000-4,000 FPM
Sensitivity	1.36-2.33%/FT @ 4000FPM
Visual Indicator (Status LED)	PILOT: Green - Normal Off - Shutoff/Detector Missing ALARM: Off - Normal Yellow - Check Voltage / Detector Head Red - Alarm
Storage Temperature Range	-30°C (-22°F) ~ 70°C (158°F)
Maximum Relative Humidity	93% RH non-condensing
Environment	Indoor dry use only, Mount to Duct Side or Top
Dimensions	7.5"W X 9.5"H X 2.5"D
Weight	Approximately 3.0lb

D. WIRING DIAGRAMS



All contacts are shown in normal supervisory condition. Alarm contacts will toggle during alarm or test switch activation. Trouble contacts will toggle to trouble condition if detector is removed. Alarm contacts must be reset by pressing the reset switch after activation.

FACTORY WIRED TERMINALS. DO NOT ADJUST.

i. REMOTE ACCESSORY WIRING

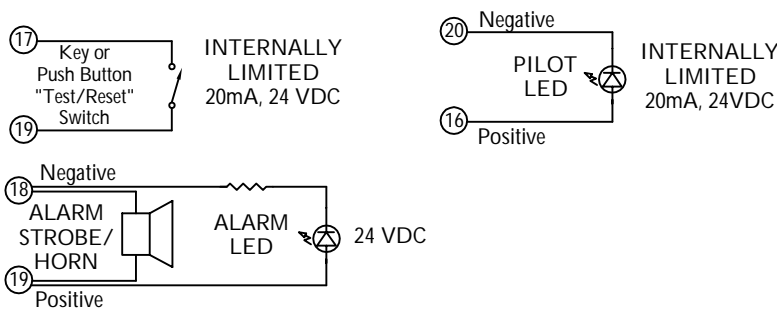

ii. FIRE ALARM CONTROL PANEL WIRING

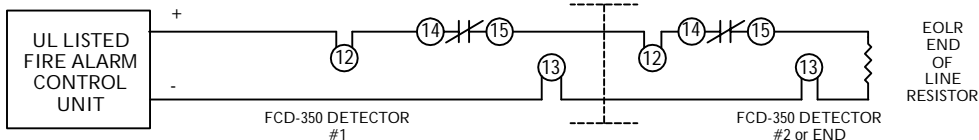

iii. COMMON FUNCTION WIRING

Up to 30 units may be interconnected for all alarm relays to operate with a single alarm. Terminals 17 and 19 are optional

REMOTE COMMON TEST/RESET
REMOTE COMMON ALARM
REMOTE COMMON AUX POWER
COMMON AUX GROUND

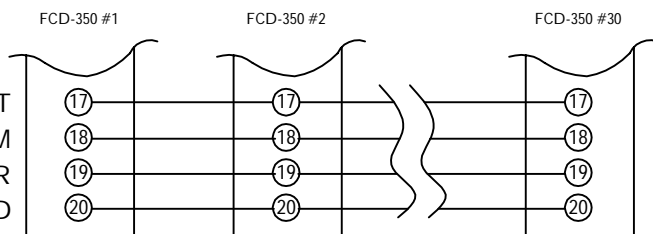

* Individual Remote Pilot LED's must be installed to monitor detector head or power source removal for each unit.

E. TESTING THE INSTALLATION

Magnet Test:

Testing can be accomplished with the cover installed or removed. Place the magnet (Part #0700-01117 or suitable bar magnet) on the detector as shown in Figure 4 / Figure 5 for approximately six (6) seconds to activate the alarm LEDs and relays. This test will verify that the detector is within its intended limits.

Model FCD-350 Automatic Verification:

The detector has a built-in sensitivity window verification feature. If the detector is within its calibrated sensitivity range the detector LEDs will flash Green in standby or normal operation. If the detector drifts outside its sensitivity range the LEDs will flash Red to indicate an out of sensitivity condition.

Smoke Test Port:

The FCD-350 has a smoke port for the introduction of smoke or simulated smoke without cover removal by lifting the port tab. To test with aerosol smoke, use a 1/2 inch diameter pipe (or equivalent) at the manufacturer's recommended minimum length to introduce the aerosol into the port. Press the pipe against the detector housing and spray from the opposite pipe end, pipe elbows can be used. The amount of aerosol is dependent on the duct air velocity, see below for estimated activations:

- 1,000-2,000 FPM: 3 seconds, 1 activation
- 2,000-3,000 FPM: 4 seconds, 1 activation
- 3,000-4,000 FPM: 4 seconds, 2 activations

The port must be closed after testing to avoid air leakage from the duct.

Test Switch:

Pressing the test switch will test the alarm relays, it will not test the detector's sensing element. The switch must be pressed to reset the detector after an alarm activation.

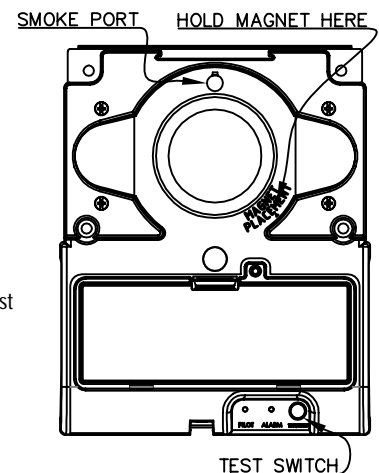

FIGURE 8. FCD-350 TEST LOCATIONS