

AUTODOME IP 4000i



- ▶ Perfect combination of style and technology for indoor installations that require high-quality imaging in a compact and aesthetic dome housing
- ▶ Integrated 12x optical zoom that clearly identifies people (90 m / 295 ft maximum) without loss of any identification details (250 pixels/m).
- ▶ Built-in Essential Video Analytics to trigger relevant alerts and quickly retrieve data
- ▶ Simple installation with flexible mounting options (in-ceiling or surface mounting)

The AUTODOME IP 4000i is a compact, indoor PTZ dome camera with a high-resolution 1080p60 HD sensor and a 12x optical zoom that allows operators to monitor wide scenes without losing any details. The camera's aesthetic design and flexible mounting options allow unobtrusive surveillance of large halls, reception areas, or waiting areas that would otherwise require multiple cameras for effective surveillance.

Functions

Superior imaging performance

Built on the digital imaging technology from Bosch, the camera is carefully tuned to maintain accurate color reproduction and to deliver high-resolution HD video with flexibility to zoom in to small details of objects.

Pre-programmed user modes

The camera comes with 3 pre-tuned scene modes to match various lighting conditions found in indoor scenes. Users can complete the configuration without going through multiple imaging settings.

- Standard: For indoor fluorescent lighting.
- Sodium-lighting: For scenarios where the video is captured under sunlight in the day or under sodium vapor lamp at night.
- Vibrant: For enhanced contrast, sharpness, and saturation

H.265 high-efficiency video encoding

The camera is designed on the most efficient and powerful H.264 and H.265/HEVC encoding platform. The camera is capable of delivering high-quality and high-resolution video with very low network load. With a doubling of encoding efficiency, H.265 is the compression standard of choice for IP video surveillance systems.

Intelligent streaming

Smart encoding capabilities, together with Intelligent Dynamic Noise Reduction technology and analytics, reduce the bandwidth consumption to extremely low levels. Only relevant information in the scene, like motion, or objects found with the analytics, need to be encoded.

The camera is capable of quad streaming which allows the camera to deliver independent, configurable streams for live viewing, recording, or remote monitoring via constrained bandwidths.

Multiple streams

The multi-streaming feature delivers various H.264 or H.265 streams together with an M-JPEG stream. These streams facilitate bandwidth-efficient viewing and recording as well as integration with third-party video management systems.

The camera can run multiple independent streams that allows to set a different resolution and frame rate on the first and second stream. The user can also choose to use a copy of the first stream. The third stream uses the I-frames of the first stream for recording; the fourth stream shows a JPEG image at a maximum of 10 Mbit/s.

Recording and storage management

Recording management can be controlled by the Bosch Video Recording Manager application, or the camera can use local storage and iSCSI targets directly without any recording software.

A memory card with a maximum of 32 GB (microSDHC) / 2 TB (microSDXC) can be used for recording "at the edge" or for Automatic Network Replenishment (ANR) technology to improve the overall recording reliability.

Pre-alarm recording in RAM reduces bandwidth consumption on the network and extends the effective life of the memory card.

Essential Video Analytics on the edge

The Essential Video Analytics application provides reliable video analytics for small and medium business, large retail stores, commercial buildings, and warehouses.

Advanced tasks like multiple line crossing, loitering, idle / removed object detection, crowd density estimation, occupancy and people counting are available for live alarming and forensic search. Object filters based on size, speed, direction, aspect ratio, and color can be defined.

A simplified calibration mode reduces installation time significantly, because you only need to enter the installation height once for each camera, independent of pre-positions.

After the camera is calibrated, the analytics engine can automatically classify objects as upright person, car, bike, or truck.

Data security

Special measures are necessary to ensure the highest level of security for device access and data transport. On initial setup, the camera is only accessible over secure channels. You must set a service-level password in order to access camera functions. Web browser and viewing client access can be protected using HTTPS or other secure protocols that support state-of-the-art TLS 1.2 protocol with updated cipher suites including AES encryption with 256 bit keys. No software can be installed in the camera, and only authenticated firmware can be uploaded. A three-level password protection with security recommendations allows users to customize device access. Network and device access can be protected using 802.1x network authentication with EAP/TLS protocol. Superior protection from malicious attacks is guaranteed by the Embedded Login Firewall, on-board Trusted Platform Module (TPM) and Public Key Infrastructure (PKI) support.

The advanced certificate handling offers:

- Self-signed unique certificates automatically created when required
- Client and server certificates for authentication
- Client certificates for proof of authenticity
- Certificates with encrypted private keys

System integration and ONVIF conformance

The camera conforms to the specifications for ONVIF Profile S and ONVIF Profile G. (ONVIF is the acronym for Open Network Video Interface Forum.) For H.265 configuration, the camera also supports Media Service 2, which is part of ONVIF Profile T. Compliance with these standards guarantees interoperability between network video products, regardless of manufacturer. Third-party integrators can easily access the internal feature set of the camera for integration into large projects. For more information, see the Bosch Integration Partner Program (IPP) website (ipp.boschsecurity.com).

Superior privacy masking

The camera allows for a total of 32 individual privacy masks, with up to eight masks displayed in the same scene. Each mask can be programmed with eight corners. Each mask changes size and shape smoothly and quickly, ensuring that the covered object cannot be seen.

PTZ drive and mechanism

The camera supports 256 pre-positions and two styles of Guard Tours: Pre-position and Record/Playback. The Pre-position tour has capability for up to 256 pre-positions with a configurable dwell time between pre-positions and can be customized as to the order and the frequency that each Pre-position is visited. The camera also provides support for two (2) recorded tours, which have a total duration of 15 minutes of movements. These are recorded macros of an operator's movements, including pan, tilt, and zoom activities, and can be played back in a continuous manner.

Pan and tilt preset repeatability are accurate to within ± 0.1 degrees to ensure that the correct scene is captured every time. The camera delivers maximum pan speed of 160 degrees per second and maximum tilt speed of 120 degrees per second. The camera is capable of manual speeds (pan and tilt) of 0.1 to 120 degrees per second. The camera provides a pan range of up to 360 degrees continuous rotation.

Sophisticated alarm responses

The camera supports advanced alarm control that uses sophisticated rules-based logic to determine how to manage alarms. In its most basic form, a "rule" could define which input(s) should activate which output(s). In a more complex form, inputs and outputs can be combined with pre-defined or user-specified commands to perform advanced camera functions.

Ease of installation and servicing

The camera has been designed for quick and easy installation, a key feature from Bosch IP video security products.

Bosch designed the camera with the knowledge that field cables and mounts are installed before the camera is mounted. The installation concept allows a single person to connect the cables directly to the camera without re-routing cables. The camera is easily secured to the mount with a single screw. The three-step installation process can save up to 5 minutes per camera installation compared to any conventional PTZ dome.

The camera models are available with a choice of in-ceiling or surface mount.

In-ceiling models are ideal for suspended ceilings, flush-in for an aesthetic look.

Surface-mount models are designed for easy installation on hard ceilings or can be pendant-mounted on a wall or a pipe with the proper mounting hardware (sold separately).

DORI coverage

DORI (Detect, Observe, Recognize, Identify) is a standard system (EN-62676-4) for defining the ability of a person viewing the video to distinguish persons or objects within a covered area. The maximum distance at which a camera/lens combination can meet these criteria is shown below:

| | DORI definition | Distance | |
|------------------|------------------------|------------------|--------------------|
| | | WIDE 1X | TELE 12X |
| Detect | 25 px/m (8 px/ft) | 69 m (226 ft) | 897 m (2943 ft) |
| Observe | 63 px/m (19 px/ft) | 27 m (89 ft) | 356 m (1168 ft) |
| Recognize | 125 px/m (38 px/ft) | 14 m (46 ft) | 179 m (587 ft) |
| Identify | 250 px/m (76 px/ft) | 7 m (23 ft) | 90 m (295 ft) |

Certifications and approvals

HD standards

- Complies with the SMPTE 274M-2008 Standard in:
 - Resolution: 1920x1080
 - Scan: Progressive
 - Color representation: complies with ITU-R BT.709
 - Aspect ratio: 16:9
 - Frame rate: 25 and 30 frames/s
- Complies with the 296M-2001 Standard in:
 - Resolution: 1280x720
 - Scan: Progressive

- Color representation: complies with ITU-R BT.709
- Aspect ratio: 16:9
- Frame rate: 25 and 30 frames/s

| Marking | Applicable Standard |
|-------------------------|---|
| cULus | <ul style="list-style-type: none"> • UL60950-1 (ed 2) (Includes CSA 22.2 No. 60950-1) |
| FCC Part 15 (USA) | <ul style="list-style-type: none"> • 47CFR Part 15 • ICES-003 (Canada) |
| CE (Europe) | <p>Electromagnetic Compatibility (EMC) Directive</p> <ul style="list-style-type: none"> • EN 55032: 2012/AC:2013 • EN 50130-4:2011/A1:2014 • EN 61000-3-2:2014 • EN 61000-3-3:2013 <p>Product Safety: Low Voltage Directive (IECEE CB scheme certificate and report are required)</p> <ul style="list-style-type: none"> • EN 60950-1:2006+A11:2009+A1:2010+A12:2011+A2:2013 (with national differences) • IEC 60950-1 (ed 1) |
| Other labels / markings | <ul style="list-style-type: none"> • RCM, EAC, WEEE, China RoHS |

For a full list of all related certifications/standards, refer to the Product Tests Report, available on the online catalog, on the Documents tab of the product page for your device. If the document is unavailable on the product page, contact your sales representative.

| Region | Regulatory compliance/quality marks | |
|--------|-------------------------------------|---|
| Europe | CE | Declaration of Conformity (DoC) |
| USA | UL | FCC Declaration of Conformity (DoC), UL 60950 |
| Canada | UL | CAN/CSA 60950 |

Installation/configuration notes

Dimensions in mm (inch)

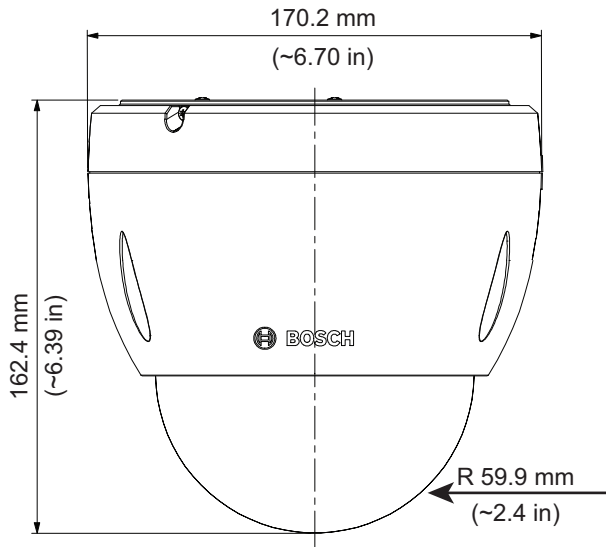

Fig. 1: Pendant model

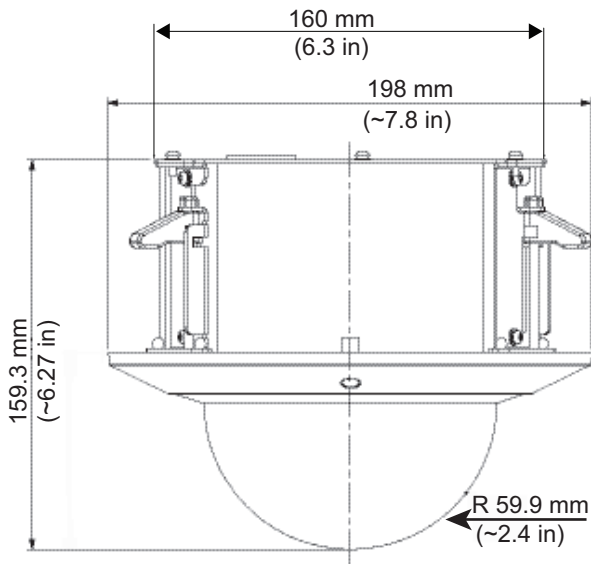
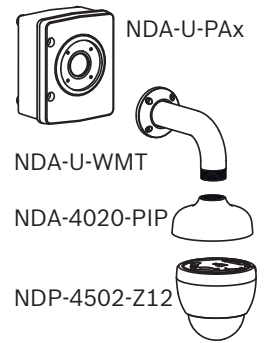
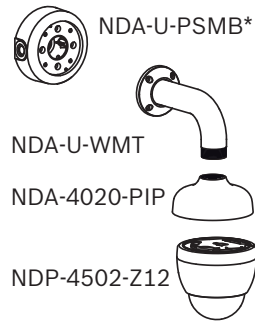

Fig. 2: In-ceiling model

Accessories

Wall mount

Wall mount with surveillance cabinet



* optional

Pendant pipe mount



NDA-U-PSMB*

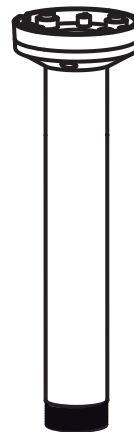

NDA-U-PMT**



NDA-4020-PIP



NDP-4502-Z12

* optional

** NDA-U-PMTE: optional 50cm / 20" extension pipe

Pole mount

Corner mount

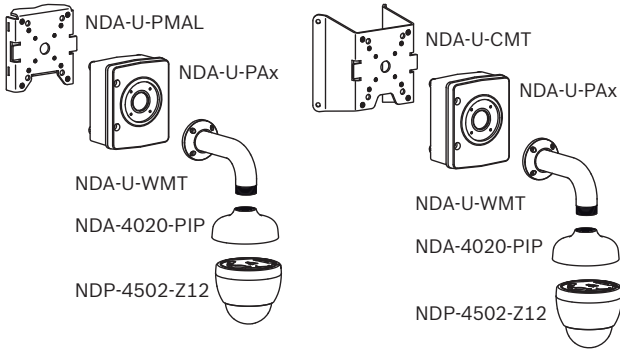

Surface mount

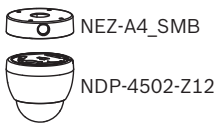

In-ceiling mount

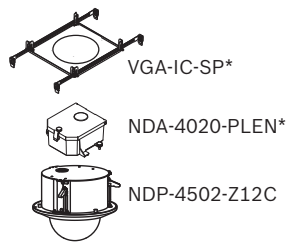

* optional

For more options, see [Quick Selection Guide: Modular camera mounts & accessories](#).

Technical specifications

| | |
|----------------------------|--|
| Imager | 1/2.8" progressive scan CMOS |
| Effective Picture Elements | 1945 x 1097 (2.13 MP) |
| Lens Focal Length | 12x Zoom 5.3 mm to 64 mm (F1.6 to F2.8) |
| Field of View (FOV) | 4.9° to 58.5° |
| Focus | Automatic with manual override |
| Iris | Automatic |
| Digital zoom | 16x |

Video performance - Sensitivity

(3100K, reflectivity 89%, 1/30, F1.6, 30 IRE)

| | |
|--------------------|--|
| Color | 0.05 lx |
| Mono | 0.01 lx |
| High dynamic range | 94 dB (measured according to IEC 62676 Part 5) |

| | |
|--------------------------------|---|
| Electronic Shutter Speed (AES) | 1/30 s to 1/15000 s (12 steps) |
| Signal-to-noise Ratio (SNR) | >55 dB (AGC off) |
| Noise Reduction | Intelligent Dynamic Noise Reduction |
| Backlight Compensation (BLC) | On/Off, Intelligent Auto Exposure (IAE) |
| Intelligent Defog | Automatically adjusts parameters for best picture in foggy or misty scenes (Auto/Off) |
| White Balance | Standard Auto, Sodium Lamp Auto, Basic Auto, Manual, Hold, Dominant Color Auto |
| Day/Night | Mechanical switchable IR filter (Auto/On/off) Monochrome |
| Sector/Titling | 16 independent sectors with 20 characters per title |
| Privacy Masks | 32 individually configurable privacy masks |
| Privacy Masks pattern | Black, White, Gray, Auto (average background color) |
| Supported Languages | English, German, Spanish, French, Italian, Dutch, Polish, Portuguese, Russian, Japanese, Chinese (simplified) |

Video content analysis

| | |
|--------------------------|---|
| Analysis type | Essential Video Analytics |
| Configurations | Silent VCA / Profile1 - 16 |
| Alarm rules (combinable) | Any object Object in field Crossing line Entering field Leaving field Loitering Following route Idle object Removed object Counter Occupancy Crowd detection Condition change Similarity search Tampering |
| Object filters | Duration |

| Video content analysis | |
|-------------------------------|---|
| | Size Aspect ratio v/h Speed Direction Color Object classes (Upright persons, Bikes, Cars, Trucks) |
| Calibration | Automatic self-calibrating when height is set |
| Mechanical | |
| Pan/Tilt Modes | Normal: 0.1°/s - 120°/s Turbo: Pan: 0.1°/s - 160°/s; Tilt: 0.1°/s - 120°/s |
| Pre-position Speed | Pan: 160°/s Tilt: 120°/s |
| Pan Range | 360° continuous |
| Tilt Angle | -90° to 0° (Auto-flip 180°) |
| Pre-position Accuracy | ± 0.1° typ. |
| Pre-positions | 256 |
| Tours | Recorded tours: two (2), maximum total duration 15 minutes (depending on the amount of commands sent during recording) Pre-position tour: one (1), consisting of up to 256 scenes consecutively, and one (1), customized up to 64 scenes |
| Electrical | |
| Input voltage | 24 VAC and PoE+ |
| Power consumption | 24 VAC: 12 W PoE+: 12 W |
| Network | |
| Video compression | H.265 H.264 M-JPEG |
| Streaming | Four (4) streams: Two (2) configurable streams in H.264 or H.265 One (1) I-frames-only stream based on first stream One (1) M-JPEG Stream |

| Frame rate | 60fps at all resolutions | |
|----------------------|---|------|
| Resolution | 1080p 720p D1 4:3 (cropped) SD (432p, 288p) | |
| IP delay (typical) | 60 fps: 200 ms | |
| Bitrate | The average typical optimized bitrate in kbits/second for various frame rates is shown in the following table: | |
| Video compression | H.265 | |
| IPS | 1080p | 720p |
| 60 | 1649 | 1249 |
| 30 | 1413 | 1096 |
| 15 | 1157 | 902 |
| 10 | 1075 | 841 |
| 5 | 746 | 597 |
| 2 | 407 | 343 |
| Ethernet | 10/100BASE-T | |
| Encryption | TLS 1.0, SSL, DES, 3DES, AES | |
| Protocols | IPv4, IPv6, UDP, TCP, HTTP, HTTPS, RTP/RTCP, IGMP V2/V3, ICMP, ICMPv6, RTSP, FTP, ARP, DHCP, APIPA (Auto-IP, link local address), NTP (SNTP), SNMP (V1, V3, MIB-II), 802.1x, DNS, DNSv6, DDNS (DynDNS.org, selfHOST.de, no-ip.com), SMTP, iSCSI, UPnP (SSDP), DiffServ (QoS), LLDP, SOAP, Dropbox™, CHAP, digest authentication | |
| Interoperability | ONVIF Profile S; ONVIF Profile G; ONVIF Profile M; ONVIF Profile T | |
| Compression | G.711, 8kHz sampling rate L16, 16kHz sampling rate AAC, 16kHz sampling rate | |
| Interface | 1/1 Channel In/Out | |
| Local Storage | | |
| Memory card slot | Support a memory card with a maximum of 32 GB (microSDHC) / 2 TB (microSDXC) (user-supplied). (An SD card of Class 6 or higher is recommended for HD recording.) | |

User Connections

| | |
|-----------------|--|
| Power | RJ45 10/100 Base-T PoE+ (IEEE 802.3at, class 4 standard) 21-30 VAC, 50/60 Hz |
| Alarm Inputs | 2 |
| Alarm Outputs | 1 relay output 5 VDC, 150 mA maximum |
| Audio | 1x mono line in, 1x mono line out |
| Signal line in | 94 kOhm typical, 1 Vrms maximum |
| Signal line out | 1 kOhm typical, 1 Vrms maximum |

Communications / Software Control

| | |
|------------------|---|
| Serial protocols | Bosch OSRD, Pelco P/D, Forward Vision, and Cohu Note: A separate license (MVS-FCOM-PRCL) is required. |
|------------------|---|

Environmental (pendant model)

| | |
|-------------------------------------|---|
| Ingress Protection Rating/ Standard | IP65 |
| IK Rating | IK10 |
| Operating temperature | -10 °C to +55 °C (+14 °F to +131 °F) |
| Humidity | Up to 90% RH, non-condensing |
| Storage temperature | -40 °C to +60 °C (-40 °F to +140 °F) |

Environmental (in-ceiling model)

| | |
|-------------------------------------|---|
| Ingress Protection Rating/ Standard | IP51 |
| Operating temperature | -10 °C to +55 °C (+14 °F to +131 °F) |
| Humidity | Up to 90% RH, non-condensing |
| Storage temperature | -40 °C to +60 °C (-40 °F to +140 °F) |

Construction (pendant model)

| | |
|----------------------|---|
| Dimensions (DIA x H) | 170.2 mm x 162.4 mm (6.7 in x 6.39 in) |
| Weight | 1.88 kg (4.14 lb) |

| | |
|-----------------------|--|
| Construction material | Housing: Aluminum Bubble: Polycarbonate |
| Standard color | White (RAL 9003) |

Construction (in-ceiling model)

| | |
|-----------------------|---|
| Dimensions (DIA x H) | 198 mm x 159.3 mm (7.8 in x 6.27 in) |
| Weight | 1.81 kg (3.99 lb) |
| Construction material | Housing: SPCC Trim ring: PC/ABS Bubble: Polycarbonate |
| Standard color | White (RAL 9003) |

Dimensions in mm (inch)

Ordering information

NDP-4502-Z12 PTZ dome 2MP 12x clear indoor surface
IP dome camera with clear bubble and indoor pendant housing. 12x zoom, 1080p HD. Essential Video Analytics, Intelligent Dynamic Noise Reduction, remote camera access, and dual power options.
Available in specific regions only.
Order number **NDP-4502-Z12 | F.01U.319.485**

NDP-4502-Z12C PTZ dome 2MP 12x clear indoor in-ceiling
IP dome camera with clear bubble and indoor in-ceiling housing. 12x zoom, 1080p HD. Essential Video Analytics, Intelligent Dynamic Noise Reduction, remote camera access, and dual power options.
Available in specific regions only.
Order number **NDP-4502-Z12C | F.01U.319.475**

NDP-4502-Z12-P PTZ dome 2MP 12x clear indoor surface
IP dome camera with clear bubble and indoor pendant housing. 12x zoom, 1080p HD. Essential Video Analytics, Intelligent Dynamic Noise Reduction, remote camera access, and dual power options.
NDAA compliant
Order number **NDP-4502-Z12-P | F.01U.396.447**

NDP-4502-Z12C-P PTZ dome 2MP 12x clear indoor in-ceil
IP dome camera with clear bubble and indoor in-ceiling housing. 12x zoom, 1080p HD. Essential Video Analytics, Intelligent Dynamic Noise Reduction, remote camera access, and dual power options.
NDAA compliant
Order number **NDP-4502-Z12C-P | F.01U.396.448**

Accessories

UPA-2450-50 PSU, 220VAC 50Hz, 24VAC 50VA out
Indoor power supply for camera. 220 VAC, 50 Hz in; 24 VAC, 50 VA out
Order number **UPA-2450-50 | F.01U.076.157**

UPA-2450-60 PSU, 120VAC 60Hz, 24VAC 50VA out

Indoor power supply for camera. 120 VAC, 60 Hz In;
24 VAC, 50 VA Out

Order number **UPA-2450-60 | F.01U.076.154**

NPD-6001B Midspan, 60W, single port, AC in

60 W indoor midspan for cameras without illuminators

Order number **NPD-6001B | F.01U.347.358**

F.01U.392.458

NDA-U-PA0 Surveillance cabinet 24VAC

Surveillance cabinet, 24 VAC input, 24 VAC output, IP66

Order number **NDA-U-PA0 | F.01U.324.947**

NDA-U-PA1 Surveillance cabinet 120VAC

Surveillance cabinet, 100 - 120 VAC 50/60 Hz input,
24 VAC output, IP66

Order number **NDA-U-PA1 | F.01U.324.948**

NDA-U-PA2 Surveillance cabinet 230VAC

Surveillance cabinet, 230 VAC input, 24 VAC output, IP66

Order number **NDA-U-PA2 | F.01U.324.949**

NDA-U-CMT Corner mount adapter

Universal corner mount, white

Order number **NDA-U-CMT | F.01U.324.946**

NDA-U-PMAL Pole mount adapter large

Universal pole mount adapter, white; large

Order number **NDA-U-PMAL | F.01U.324.944**

NDA-U-PMAS Pole mount adapter small

Pole mount adapter small

Universal pole mount adapter, white; small.

Order number **NDA-U-PMAS | F.01U.324.943**

NDA-U-PMT Pendant pipe mount, 12" (31cm)

Universal pipe mount for dome cameras, 31 cm, white

Order number **NDA-U-PMT | F.01U.324.940**

NDA-U-PMTE Pendant pipe extension, 20" (50cm)

Extension for universal pipe mount, 50 cm, white

Order number **NDA-U-PMTE | F.01U.324.941**

NDA-U-PSMB Pendant wall/ceiling mount SMB

Surface mount box (SMB) for wall mount or pipe mount.

Order number **NDA-U-PSMB | F.01U.324.942**

NDA-U-WMP Wall mount plate

Back plate for universal wall mount, corner mount and
pole mount, white, IP66

Order number **NDA-U-WMP | F.01U.324.950**

NDA-U-WMT Pendant wall mount

Universal wall mount for dome cameras, white

Order number **NDA-U-WMT | F.01U.324.939**

NEZ-A4-SMB Surface mount box

Surface mount kit for AUTODOME IP 4000 HD. White.

Order number **NEZ-A4-SMB | F.01U.313.457**

VGA-IC-SP Suspended ceiling support kit,7"

Suspended ceiling support kit for dome cameras.

Aperture Ø177 mm (Ø7 in). Maximum supported weight
11.3 kg (25 lb).

Order number **VGA-IC-SP | F.01U.245.271**

MNT-ICP-ADC Drop ceiling support kit for AUTODOME

Suspension ceiling support kit for AUTODOME IP
4000/5000/7000 AND VG5-100/600 series in-ceiling
cameras

Order number **MNT-ICP-ADC | F.01U.316.128**

NDA-4020-PIP Pendant interface plate AUTODOME 4000

Pendant interface plate for AUTODOME IP 4000i.

Order number **NDA-4020-PIP | F.01U.324.952**

NDA-4020-PLEN Plenum box for PTZ dome

In-ceiling housing for plenum spaces for AUTODOME IP
4000i and AUTODOME IP 5000i cameras. Available in
specific regions only.

Order number **NDA-4020-PLEN | F.01U.396.548**

F.01U.324.915

NDA-4020-PTBL Tinted bubble for PTZ dome

Order number **NDA-4020-PTBL | F.01U.396.549**

F.01U.332.329

NEZ-A4-BUB-CTIP Bubble, tinted, for in-ceiling model

Tinted bubble for in-ceiling model of AUTODOME IP
4000i cameras.

Order number **NEZ-A4-BUB-CTIP | F.01U.396.551**

F.01U.313.100

VG4-SFPSCKT Ethernet to SFP interface kit

Ethernet media converter video transmitter/data receiver
fiber optic kit for AUTODOME cameras, for MIC-IP-PSU
for MIC analog cameras and for the Surveillance cabinets
(NDA-U-PA0, NDA-U-PA1 and NDA-U-PA2).

Order number **VG4-SFPSCKT | F.01U.142.529**

SFP-2 Fiber module, multimode, 1310nm, 2LC

SFP Fiber Optic Module, 2 km (1.2 miles), 2 LC
connectors.

Multi-mode

1310 nm

Order number **SFP-2 | F.01U.136.537**

SFP-3 Fiber module, single-mode, 1310nm, 2LC

SFP Fiber Optic Module, 20 km (12.4 miles), 2 LC
connectors.

Single-mode

1310 nm

Order number **SFP-3 | F.01U.136.538**

SFP-25 Fiber module, 1310/1550nm, 1SC

SFP Fiber Optic Module, 2 km (1.2 miles), 1 SC
connector

Multi-mode

1310/1550 nm

Order number **SFP-25 | F.01U.136.541**

SFP-26 Fiber module, 1550/1310nm, 1SC

SFP Fiber Optic Module, 2 km (1.2 miles), 1 SC
connector

Multi-mode

1550/1310 nm

Order number **SFP-26 | F.01U.136.542**

Services**EWE-AD4HD-IW 12 mths wrty ext AUTODOME IP 4000 HD**

12 months warranty extension without moving parts,
wear parts are excluded

Order number **EWE-AD4HD-IW | F.01U.346.302**

Represented by:

Europe, Middle East, Africa:
Bosch Security Systems B.V.
P.O. Box 80002
5600 JB Eindhoven, The Netherlands
Phone: + 31 40 2577 284
emea.securitysystems@bosch.com
emea.boschsecurity.com

Germany:
Bosch Sicherheitssysteme GmbH
Robert-Bosch-Ring 5
85630 Grasbrunn
Germany
www.boschsecurity.com

North America:
Bosch Security Systems, LLC
130 Perinton Parkway
Fairport, New York, 14450, USA
Phone: +1 800 289 0096
Fax: +1 585 223 9180
onlinehelp@us.bosch.com
www.boschsecurity.us

Asia-Pacific:
Robert Bosch (SEA) Pte Ltd, Security Systems
11 Bishan Street 21
Singapore 573943
Phone: +65 6571 2808
Fax: +65 6571 2699
apr.securitysystems@bosch.com
www.boschsecurity.asia