

Extension board with 16-input 16-output

API-AMC2-16IOE

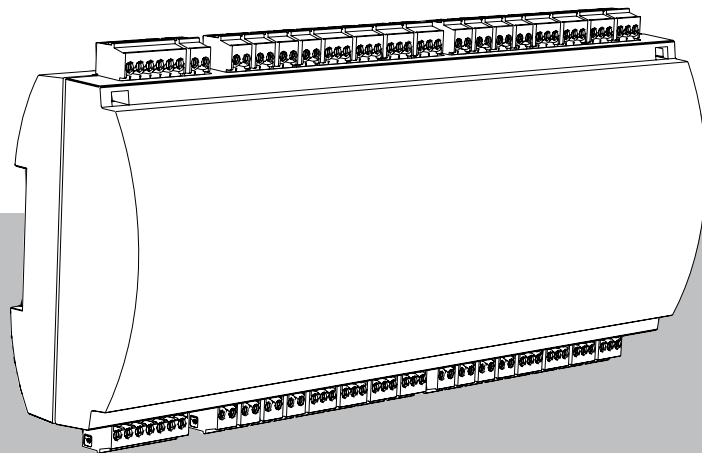

Table of contents

1	Safety	4
1.1	FCC Class B	5
2	Short information	6
3	Introduction	7
3.1	Description	7
3.2	Product overview	8
3.3	System overview	9
4	Installation	10
4.1	Mounting the device on a mounting rail	10
4.2	Unmounting the device from a mounting rail	11
4.3	Opening the case	12
4.4	Closing the case	13
4.5	Cabling	14
4.5.1	Choosing the appropriate cable to avoid high power drops	14
4.6	Grounding and shielding	15
4.6.1	Grounding for extension interface	16
4.7	Connecting the power supply to the extension	17
4.7.1	Direct power supply	17
4.7.2	Power supply via RS-485 interface	18
4.7.3	Overview - Power supply/consumption	18
4.8	RS-485 interface	20
4.8.1	Addressing	21
4.9	Connecting relay outputs	22
4.10	Connecting analog input devices	24
4.11	Tamper protection	26
5	UL requirements	27
5.1	System requirements	27
5.1.1	Computer	27
5.2	UL 294 level descriptions	27
5.3	Installation instructions	28
5.4	Extended technical specification	31
5.4.1	RS-485 extension	31
5.4.2	Power consumption	31
6	Troubleshooting	32
7	Service and repair	34
8	Disposal	35
9	Technical specifications	36
10	Appendices	37
10.1	Connecting diagrams	37

1 Safety

**Warning!****Read instructions**

Before working with the device, read these instructions carefully. Make sure you have understood all information described in this document.

**Caution!****Fire hazard and risk of electric shock due to unauthorized spare parts and accessories**

Unauthorized spare parts and accessories might lack grounding wires or other safety elements. External power supplies must be installed by qualified personnel. The service technician must use replacement parts or accessories that are specified by the manufacturer.

**Warning!****Risk of physical injury due to blocked escape routes**

This product may block escape routes if not installed correctly. To keep escape routes free:

- Use locks in fail-safe mode, so that doors can be released if power fails.
- Install manual override switches, such as break-glass or lever stations, to unlock doors in an emergency.

**Notice!****Device damage due to incorrect mounting**

Mount this product on the matching mounting rails.
If the device falls or is damaged, check it before the installation.

**Notice!****Considerations on local regulations**

When you install the device, consider any local fire, health and safety regulations.

**Notice!****Device damage due to electrostatic discharge**

Protect the hardware from electrostatic discharge, especially when the device is open and exposed. Always disconnect the device from the power source before modifying the installation. This product does not support hot plugging.

**Notice!****Unauthorized access**

If this product is installed in an unprotected environment, unauthorized people may be able to enter.

Install the product in a location with restricted access.

This device is not suitable for use in locations where children may be present.

**Notice!**

Some features and functions described in this document depend on the firmware loaded into the device and host software. Make sure that the controller is updated to the firmware version provided with the host system.

1.1 FCC Class B

This device complies with part 15 of the FCC Rules. Operation is subject to the following two conditions: (1) This device may not cause harmful interference, and (2) this device must accept any interference received, including interference that may cause undesired operation.

Changes or modifications not expressly approved by the party responsible for compliance could void the user's authority to operate the equipment.

Note: This equipment has been tested and found to comply with the limits for a Class B digital device, pursuant to Part 15 of the FCC Rules. These limits are designed to provide reasonable protection against harmful interference in a residential installation. This equipment generates, uses, and can radiate radio frequency energy and, if not installed and used in accordance with the instructions, may cause harmful interference to radio communications. However, there is no guarantee that interference will not occur in a particular installation. If this equipment does cause harmful interference to radio or television reception, which can be determined by turning the equipment off and on, the user is encouraged to try to correct the interference by one or more of the following measures:

- Reorient or relocate the receiving antenna.
- Increase the separation between the equipment and receiver.
- Connect the equipment into an outlet on a circuit different from that to which the receiver is connected.
- Consult the dealer or an experienced radio/TV technician for help.

2 Short information

With the extension, the AMC2 controller, from now on referred as controller, can be extended with the appropriate number of inputs and outputs. This results in a wide range of further control options.

Each controller can be connected to a maximum of 3 additional extensions. The variants AMC2-8IOE, AMC2-16IOE and AMC2-16IE can be combined as required.

The extensions do not have their own memory or processor, therefore no data or events are stored here.

The Access Modular Controller (AMC) is supported by the Access Professional Edition (APE), BIS Access Engine (ACE) and the Access Management System (AMS).

For the latest information about our products, visit our online product catalog:

www.boschsecurity.com/xc/en/product-catalog/

Manufacturing dates

For product manufacturing dates, go to www.boschsecurity.com/datecodes/ and refer to the serial number on the product label.

Remarks

This hardware is part of a security system.

Access should be granted to authorized people only.

Some states do not allow the exclusion or limitation of implied warranties, or limitation of liability for incidental or consequential damages, hence the above limitation or exclusion might not apply to you.

If you need further assistance or have any questions, contact:

Bosch Security Systems B.V.

Torenallee 49

5617 BA Eindhoven

Netherlands

www.boschsecurity.com

© Bosch Security Systems B.V., 2023

3 Introduction

3.1 Description

The extension AMC2-16IOE can be used with a controller. It allows to extend a controller with additional input and output ports.

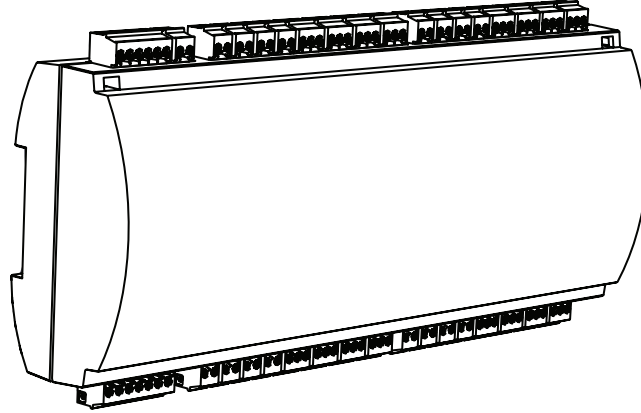

Figure 3.1: The extension AMC2-16IOE

The API-AMC2-16IOE has 16 analog inputs and 16 relay outputs.

The analog inputs can be wired with potential-free contacts, such as door or relay contacts.

The relay outputs can be actively connected with the internal voltage, as well as used potential free.

The extension electronics are completely covered by a plastic housing.



Notice!

The extension has no display. The information about the inputs and outputs will be shown on special pages of the connected controller display.



Notice!

The inputs and outputs can only be parameterized for passages or functions on the controller connected to the extension. The inputs and outputs cannot be used for other controllers across the network.

3.2 Product overview

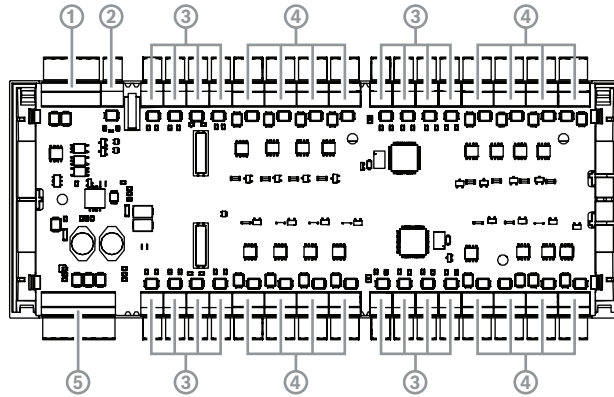

Figure 3.2: Overview - Interfaces

1	RS-485 extension module bus
2	External tamper contact
3	Connectors for analog inputs
4	Connectors for relay outputs
5	Connector for power supply

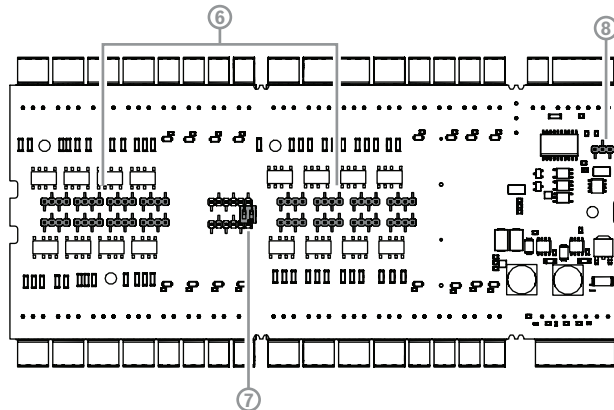

Figure 3.3: Jumpers at the bottom side

6	Jumper for setting either a free voltage from the relay output or a looped-in voltage from the internal power supply of the controller.
7	DIL switch for setting the board address.
8	Jumper: Equalization of potential between different systems and earth ground (shield) for the extension module bus.

3.3 System overview

The extensions can be connected to the controller through the RS-485 extension module bus. A maximum of three IO extensions can be connected to one controller. The extension must be addressed accordingly (1-3). In the example, the power is supplied via the controller. If necessary, it is also possible to use a separate power supply for an extension.

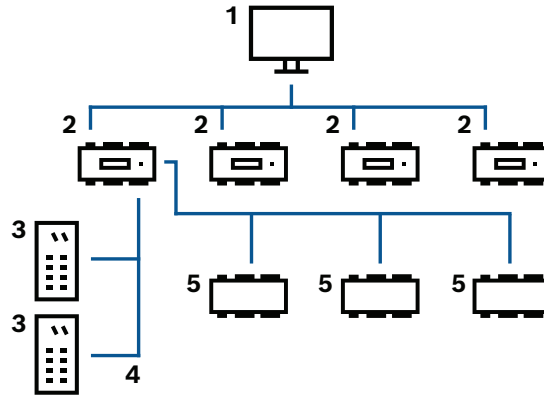

Figure 3.4: System overview

1	Host computer
2	Access Modular Controller
3	Card reader
4	Communication and power supply
5	Extension

4 Installation

4.1 Mounting the device on a mounting rail

The extension can be attached on a standard 35 mm (1.377 in.) mounting rail using a snap-in mechanism. Attach the extension into the upper edge of the mounting rail [1], then push down the device and snap it onto the rail by pushing it towards the back [2].

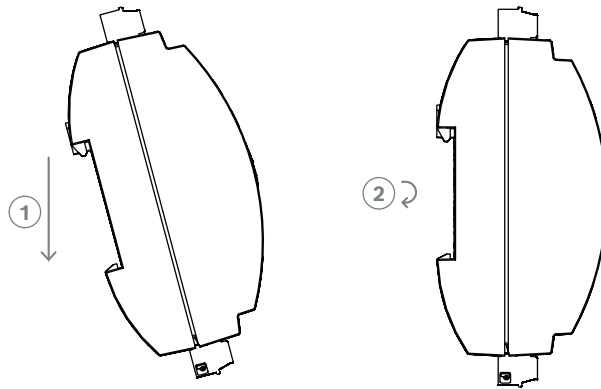

Figure 4.1: Mounting the AMC2 device on a mounting rail

For information on how to install the device in an enclosure, refer to the separate instruction manual of the enclosure AEC-AMC2-UL01 or AEC-AMC2-UL02. After installing the device, keep the door of the enclosure closed.

4.2 Unmounting the device from a mounting rail

**Notice!**

To remove the extension from a mounting rail, first remove all wired pluggable connectors.

Push down the extension until the lower edge snaps out of the mounting rail [1]. Pull the lower end of the extension from the mounting rail [2].

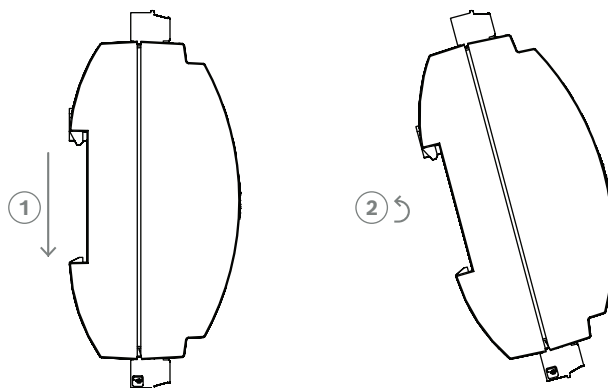

Figure 4.2: Unmounting the AMC2 device on a mounting rail

4.3 Opening the case

**Notice!**

To open the extension, first remove all wired pluggable connectors.

The extension's case consists of a top cover mounted with a two-point snap-in closure on a chassis. To open the case, push down the two snap-ins with a screwdriver, then swing the cover down.

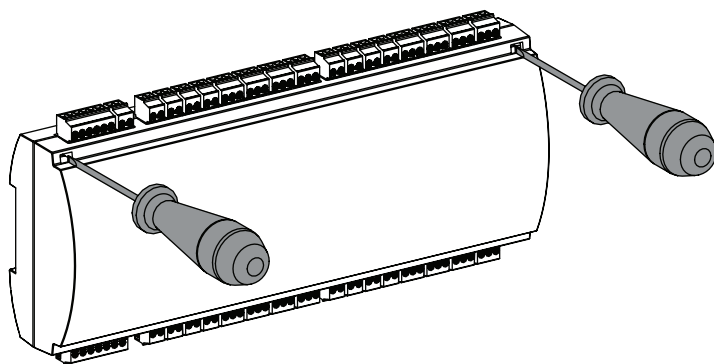

Figure 4.3: Opening the AMC2-16IOE case

4.4 Closing the case

Insert the hooks on the lower edge of the front cover into the lugs on lower edge of the plastic back cover [1]. Ensure that the BOSCH logo is not upside-down. The upper edge of the front cover now aligns with the two-point snap-in closures on the upper edge of the back cover [2], and may thus be clicked gently into place.

Hence the closing process is the reverse of the opening process.

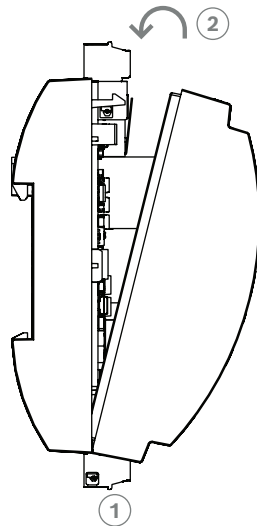

Figure 4.4: Closing the extension case



Notice!

Risk of damage to equipment

If excessive force is required to close the front cover then it is probably incorrectly hooked into the back cover. In this case, remove the cover again and check whether the lower brackets are positioned correctly.

4.5 Cabling



Notice!

Risk of malfunction

When connecting the extension to the controllers, twisted pair shielded cables should be used. The other cables used are not susceptible to electrical interference. However, you should avoid laying cables close to heavy-duty switch cables and equipment. If this is unavoidable, cross the cables at right angles every 1 to 2 m (3 to 6 ft) to reduce interference.

4.5.1

Choosing the appropriate cable to avoid high power drops

With the calculation below you can find out which cable type must be used. If you connect the power supply and the extension with the delivered cable set from the enclosure, the calculation is not necessary.

For distances below 25 m (75 ft) use AWG18 conductors (1mm²). For longer distances, install an additional power supply close to the extension.

Please, calculate the voltage drop by checking the conductor specifications for characteristic resistance values. The voltage drop shall not exceed 2 V.

Example:

Length = 100 m/328 ft

$$U = 12V, I = 1A, \text{maximum } U_{Drop} = 2V$$

$$i. e. \text{RAWG18 (acc. specs)} = 6.385 \frac{\Omega}{1000 \text{ ft}} \text{ or } 20,948 \frac{\Omega}{\text{km}}$$

$$U_{Drop} = 20,948 \frac{\Omega}{\text{km}} \times 0.1 \text{ km} \times 1A = 2.1V$$

$$U_{Drop} = 6.385 \frac{\Omega}{1000 \text{ ft}} \times 328 \text{ ft} \times 1A = 2.1V$$

Critical condition! Install the power supply closer to the extension.



Notice!

These specifications apply to power supply, relay outputs, and extension interface. Regarding inputs, specific voltage-drop values need to be taken into account. Refer to chapter *Connecting analog input devices*, page 24.

4.6 Grounding and shielding

The main grounding point at the extension is connected to pin 2 of the power supply connector. For more information on these connections, refer to chapter *Connecting diagrams*, page 37.

It is good practice to shield all wires carrying low level signals.

If the extension is powered by the controller, as in number 2 of *Overview - Power supply/consumption*, page 18, the connection should be made as shown in the connection diagram of *RS-485 interface*, page 20.

**Notice!**

The functional earth ground symbol  identifies a functional part that allows installing an electrical system in an electromagnetically compatible manner.

**Notice!**

If the shield is set in the extension, the appropriate jumpers for shielding must also be set in the controller. See the corresponding installation manuals of the controller.

**Notice!**

Risk of malfunction
Ensure that no ground loops are formed.

**Notice!**

In general the following apply:
If the devices have their own power supplies, the shielding is applied to one side only. The free end should be insulated to avoid inadvertent connections.
If one device is fed power by another, the cable shielding should be applied to both sides.

4.6.1 Grounding for extension interface

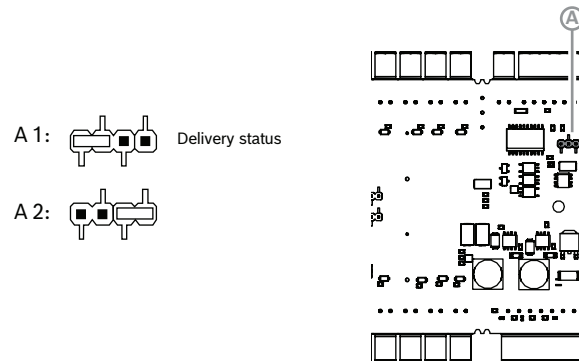

Figure 4.5: Location of ground jumper bottom side

A1	Delivery status
----	-----------------

Jumper A connects the internal ground of the controller to the RS-485 ground of the slave interface. Only set jumper A (A2) if the controller powers all other peripheral devices directly connected to it.

4.7 Connecting the power supply to the extension

4.7.1 Direct power supply

Connect the power supply to the POWER 7-pin pluggable screw connector.

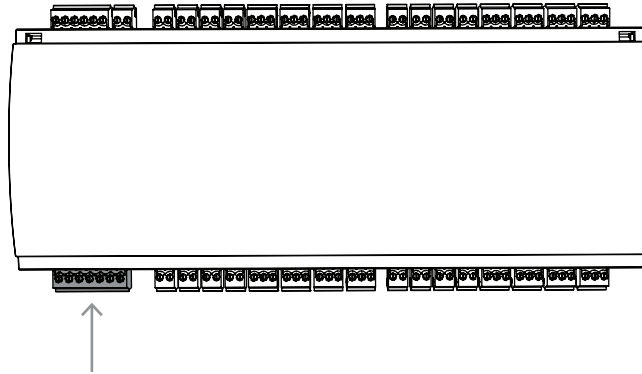

Figure 4.6: Location of the power supply connector

Connect an external power supply (10 VDC - 30 VDC) to the extension at pin 1 (positive) and pin 3 (0 V) of the pluggable screw connector.

Bosch recommends using the Bosch APS-PSU-60 power supply unit.

This power supply can also be used as an Uninterruptible Power Supply (UPS) when using the appropriate batteries. It also has relay outputs for monitoring the power good signals.

These can be connected to:

- pin 4 and 7 for power good AC
- pin 5 and 7 for power good Battery
- pin 6 and 7 for power good DC.

If the recommended power supply is not in use, it is useful to have these pins short-circuit.

Notice!

If a battery is used, the power supply unit (PSU) checks the battery status every 5 minutes. During the self-test, the PSU switches its output from AC regulated power to battery regulated power. This causes the device to be supplied by the battery only.

Make sure that the battery is maintained according to the advice of the manufacturer, in order to reduce the risk of losing the power on the device during self-test.

The duration of this self-test is of approximately 1 second.

The **Power Good AC** signal is switched off during the self-test.

If no battery is connected, the PSU does not perform any self-test.

Depending on the security level of your building, it is recommended to replace the battery more frequently (e.g. every 3 years, in order to keep the system running properly).



4.7.2 Power supply via RS-485 interface

The power can also be supplied by the controller. In this case, the supply voltage is also connected (pin 1-2) in addition to the data lines (pin 3 - 6).
Make sure that only one of the power supplies is connected.



Figure 4.7: Interface for internal power supply

4.7.3 Overview - Power supply/consumption

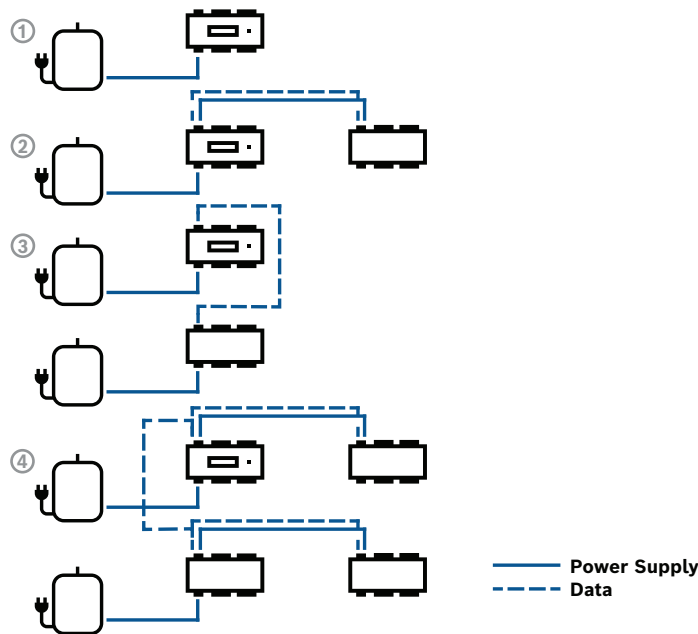

Figure 4.8: Example configurations

Example	Used components	Output power	Own Usage	available	Constant load
1	PSU + controller	60VA	5VA	55VA	25VA
2	PSU + controller + extension	60VA	2 x 5VA	50VA	20VA
	using further extensions the values decrease				
	PSU + controller + 2 x extension	60VA	3 x 5VA	45VA	15VA
	PSU + controller +	60VA	4 x 5VA	40VA	10VA

Example	Used components	Output power	Own Usage	available	Constant load
	3 x extension				
3	PSU + controller and PSU + extension	60VA + 60VA	5VA + 5VA	55VA + 55VA	25VA + 25VA
	using further extensions the values decrease				
	PSU + controller and PSU + 2 x extension	60VA + 60VA	5VA + 2 x 5VA	55VA + 50VA	25VA + 20VA
	PSU + controller and PSU + 3 x extension	60VA + 60VA	5VA + 3 x 5VA	55VA + 45VA	25VA + 15VA
using more than two extensions this combination is recommended					
4	PSU + controller + extension and PSU + extension + extension	60VA + 60VA	2 x 5VA + 2 x 5VA	50VA + 50VA	20VA + 20VA

Table 4.1: Overview - power supply and power consumption

Explanations for the table columns:

- Output power** Power provided by the power supply unit.
- Own usage** Power used by the controller.
- Available** Power remaining for external devices
- Constant load** Amount of the available power that can be drawn constantly.

Hence **Example 1** can be read as follows:
 Of the total incoming power (60VA) 5VA will be drawn by the controller. This leaves 55VA to support external devices. 25VA of these 55VA can be used for constant load (e.g. a card reader) leaving 30VA for occasional peak usage (e.g. a door opener).

4.8 RS-485 interface

The extension is connected to the controller using the RS-485 extension module bus. This interface will also be used to connect further extensions.



Figure 4.9: Location of the RS-485 extension module bus

For additional inputs and outputs, every controller can be connected to a maximum of 3 extensions, for example, for elevator control.

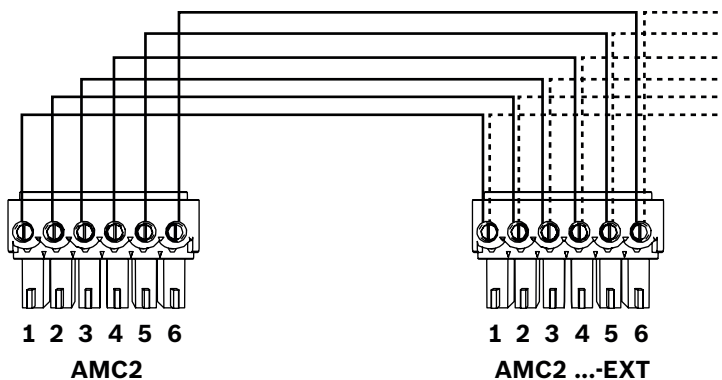

Figure 4.10: Connection of an extension module to a controller

4.8.1

Addressing

The address of the board is set using a switch on the board's underside (see Equipment Configuration).



Notice!

When configuring the system, ensure that the order of boards in the access control software corresponds to the addresses set when using this switch.

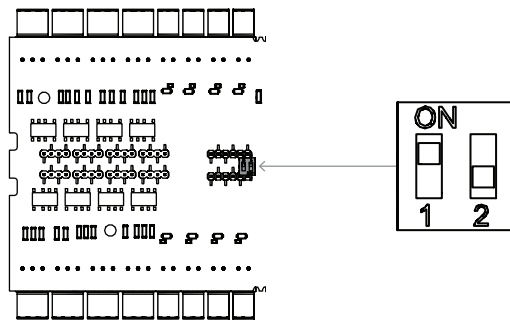

Figure 4.11: Location of the selector for host settings

Address	DIP switches	
	1	2
none	OFF	OFF
1 (delivery status)	ON	OFF
2	OFF	ON
3	ON	ON

4.9 Connecting relay outputs

The AMC2-16IOE has 16 relay outputs. The outputs will be connected to the 3-pin pluggable screw connectors S6, S7, S8, S9, S14, S15, S16, S17, S24, S25, S26, S27, S32, S33, S34 and S35 - refer to chapter *Connecting diagrams*, page 37.



Figure 4.12: Location of the relay output connectors

By default, the relay outputs are connected as floating contacts (E1). However, it is possible to connect the internal voltage 12/24 V to each relay output (E2) to control external consumers.

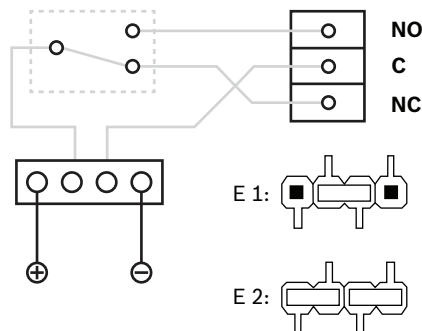

Figure 4.13: Relay mode settings

Notice!

Risk of damage to equipment

To prevent damage to the relays, note these specifications:

- The maximum switching current is 1.25 A.
- The maximum switching voltage is 30 VDC.
- Only OHM resistive load can be connected to the relay.
- Inductive loads have to be short circuited using recovery diodes. The diodes (1N4004) are supplied with every extension.
- If you need higher voltage or current for special applications, or electric door holding magnets, you have to use coupling relays (e.g. Wieland flare move) on the outputs.
- Note that the coupling relays must be selected according to the supply voltage (12 V, 24 V) of the controller.



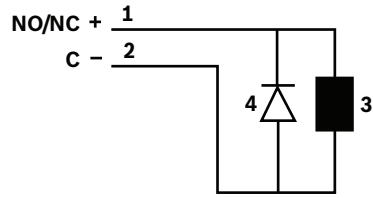

Figure 4.14: Recovery diode schematic

1	Normally open / normally closed	2	Common
3	Inductive load	4	Recovery diode



Notice!

When you use the recovery diode, make sure to use it in the reverse direction.

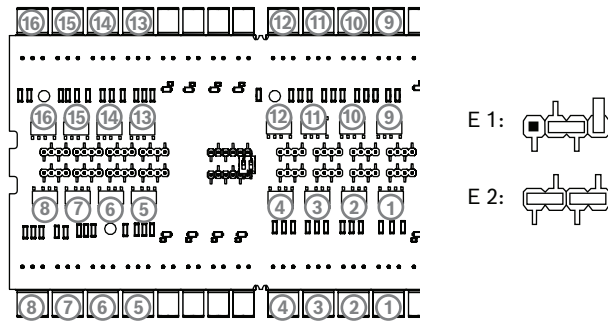

Figure 4.15: Location of relay output jumpers (bottom side)

E1	Delivery status
----	-----------------

4.10 Connecting analog input devices

The AMC2-16IOE has 16 analog inputs. The inputs will be connected to the 2-pin pluggable screw connectors: S2, S3, S4, S5, S10, S11, S12, S13, S20, S21, S22, S23, S28, S29, S30 and S31.

For more information on these connections, refer to *Connecting diagrams*, page 37.



Notice!

Risk of damage to equipment

Do not connect external power supply to the extension inputs.

When connecting a relay output directly to an extension input use potential-free contact - refer to *Connecting relay outputs*, page 22.

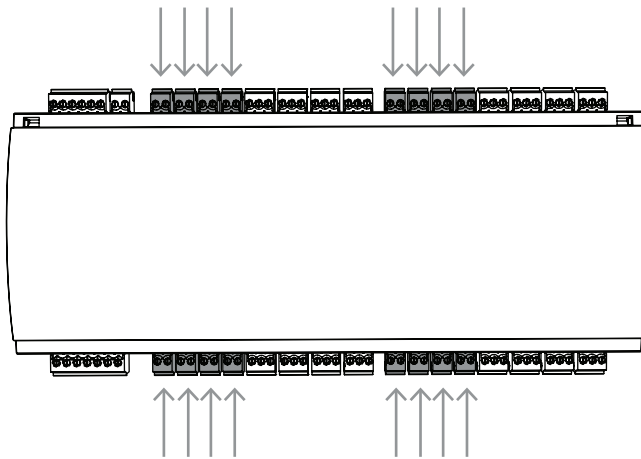

Figure 4.16: Location of the analog input connectors

The controller can also detect the wiring conditions ‘short circuit’ and ‘broken’, and hence trigger an alarm if the appropriate devices are connected.

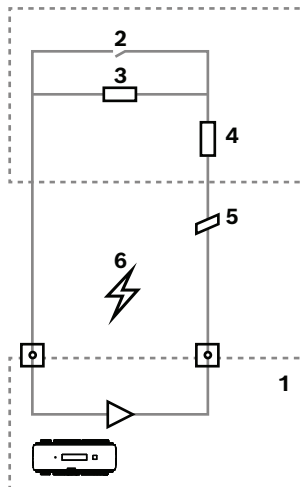

Figure 4.17: Circuit diagram

1	AMC2 analog input	2	Monitoring / door contact
3	Resistor parallel (R_p)	4	Resistor serial (R_s)
5	Broken wire	6	Short circuit

- Door open: $R_s + R_p$
- Door closed: R_s
- Open wire: $R_s + R_p = \infty$
- Short circuit: $R_s + R_p = 0$

The resistor values can vary and depend on the used lock system.

The extension package includes 2.2 kΩ resistors which can be used to replace R_s and R_p resistors.

To detect the four states, the voltage drop in the connecting cable may not exceed special values. The following table shows the maximum values of permissible cable resistance depending on the used resistor combination.

R_p	1k	1k2	1k5	1k8	2k2	2k7	3k3	3k9	4k7	5k6	6k8	8k2
R_s												
1k	220	220	220	210	200							
1k2	260	270	270	270	260	240						
1k5	310	330	340	350	350	340	310	280				
1k8	340	380	390	410	410	410	400	370	330	290	200	
2k2		430	460	490	510	520	510	500	460	420	340	240
2k7		490	540	570	620	630	640	640	620	580	510	420
3k3			610	650	700	740	770	780	770	750	700	620
3k9				720	790	850	890	910	910	910	880	810
4k7					880	960	960	970	1100	1100	1050	1050
5k6						1050	1100	1200	1200	1300	1300	1250
6k8							1300	1400	1500	1500	1500	1500
8k2								1500	1650	1700	1800	1900

Table 4.2: Maximum values of cable resistance per used resistor combination in Ohm



Notice!

We recommend using serial resistors (R_s) no higher than 5K6 in order to obtain clear measurements.

4.11 Tamper protection

The extension provides an additional interface to connect external tamper contacts. This interface is a potential-free 2-pin pluggable screw connector marked with **T**. When not in use, this tamper contact should be shorted.



Figure 4.18: Location of the tamper protection contact



Notice!

Since the extension does not have its own display, the status information of the input and output signals is shown on the display of the connected controller. For further information, refer to the installation manual of the respective controller.

5 UL requirements

Before installing the product in an UL system, read and follow the UL requirements described below.

Depending on the Host Management, the system consists of:

The Access Professional Edition (APE) 3.4 or 3.5 or Building Integration System (BIS) - Access Engine (ACE) 4.5, or AMS 2.0 or 3.0 as the Host Management System. This is an Access Control (UL 294 ALVY) system. It consists of the following devices - all listed to UL 294:

- The maximum number of controllers varies depending on the type of license (AMC2-xWCF, downloader version 00.49 or higher, program version 37.xx).
- The AMC2-xWCF controller can be extended with one AMC2-4WE device.
- Every controller can be extended with up to three AMC2-8IOE, AMC2-16IOE or AMC2-16IE in any combination.
- The enclosures AMC2-UL01 (for one device) or AMC2-UL02 (for two devices).
- For every enclosure, a power supply Bosch APS-PSU-60 is necessary, and must be located in the same room as the connected AMC2 device. Recommended maximum distance between power supply unit and AMC2 is 3 m (9.84 ft).

**Notice!**

The use of the burglar alarm, panic hardware, and elevator control have not been evaluated by UL.

**Notice!**

This section applies to APC product versions. ADS product versions have not been evaluated by UL.

5.1 System requirements

5.1.1 Computer

Host system

For detailed information about the needed Operating system and Hardware, please refer to the corresponding installation manual of the used Management system.

**Notice!**

Computers used for UL installations must be UL listed by the Information Technology Equipment Group (ITE).

5.2 UL 294 level descriptions

The following UL 294 levels apply:

- ACCESS CONTROL DESTRUCTIVE ATTACK LEVEL I - An access control product intended for, but not limited to, a controlled area that is not required to meet the destructive Attack Test.
- ACCESS CONTROL LINE SECURITY LEVEL I - An access control product with no communication line security.
- ACCESS CONTROL ENDURANCE LEVEL IV - An access control product shall operate as intended at rated voltage and current for 100,000 cycles of intended operation.

- ACCESS CONTROL STANDBY POWER LEVEL II - An access control product for units employing Model APS-PSU-60 Power Supply for 12 VDC and 24 VDC Mode. Level II operates for 30 minutes.

5.3 Installation instructions

This system is to be installed indoors within the protected or restricted area.

The UL evaluated configuration requires the following restrictions:

- A connected Host Management System to configure the AMC2 controller, manage card user database, etc. After configuration is done, the AMC2 controller is still able to work as intended, without any connection to the Host Management System. However, alarm status of the system will not be reflected.
- UL evaluated that the protection is set by the Access System Software as supplementary monitoring equipment.
- The enclosure AMC2-UL01 or AMC2-UL02 is necessary. The AMC2 Controller and Extension devices must be installed in one of these enclosures.
- The tamper contact of the AMC2 Controller must be connected to the tamper switch of the enclosure.
- In one enclosure: when using an AMC2 controller and an AMC2 extension board, if the AMC2 extension board is supplied via the extension interface, the AC fail, DC fail, and BAT fail contacts must be shorted.
- The door locks should be connected as fail safe (NFPA 101).
- For host system connection, only the Ethernet (RJ45) port must be used. **The RS-232 and RS-485 host connections may not be used in UL installations.**
- The RS-485 slave connection may be used for connection to other AMC2 Extension devices only. It may not be used for connection to readers or other accessories.
- All units are to be powered by the Bosch APS-PSU-60 power supply for UL installations. The power supply must be located in the same room as the connected AMC2 device. Recommended maximum distance between power supply unit and AMC2 is 3 m (9.84 ft).
- Wiring methods shall be in accordance with the National Electrical Code (ANSI/NFPA70 - Articles 725 and 800), local codes, and the Authority Having Jurisdiction (AHJ).
- All interconnecting devices and wiring must be UL listed and or/recognized.
- The minimum wire size used for connecting external devices shall be at least 26 AWG, depending on the electrical power consumption.
- Products are not intended to be installed or mounted in air-handling spaces.
- To detect the four states of the input, the voltage drop in the connecting cable may not exceed special values. For UL installations only the RS = 2k Ω and RP = 2k Ω End-of-Line resistors may be used.

The supply line transient protection complying with the Standard for Transient Voltage Surge Suppressors, UL 1449, with a maximum marked rating of 330 V must be used in conjunction with the Host Management System.

The signal line transient protection complying with the requirements for the Standard for Protectors for Data Communication and Fire Alarm Circuits, UL 497B, with the maximum marked rating of 50 V.

The communication circuits and network components connected to the telecommunications network shall be protected by secondary protectors for communication circuits. These protectors shall comply with the Standard for Secondary Protectors For Communication Circuits, UL 497A. These protectors shall be used only in the protected side of the telecommunications network.

The equipment should be installed in a temperature controlled environment. A temperature controlled environment is defined as one that can be maintained between 13 - 35° C (55 - 95° F) by the HVAC system. Twenty-four hours of standby power shall be provided for the HVAC system. The standby power system for the HVAC system may be supplied by an engine driven generator alone. A standby battery is not required to be used.

For UL compliance, use only UL Listed readers.

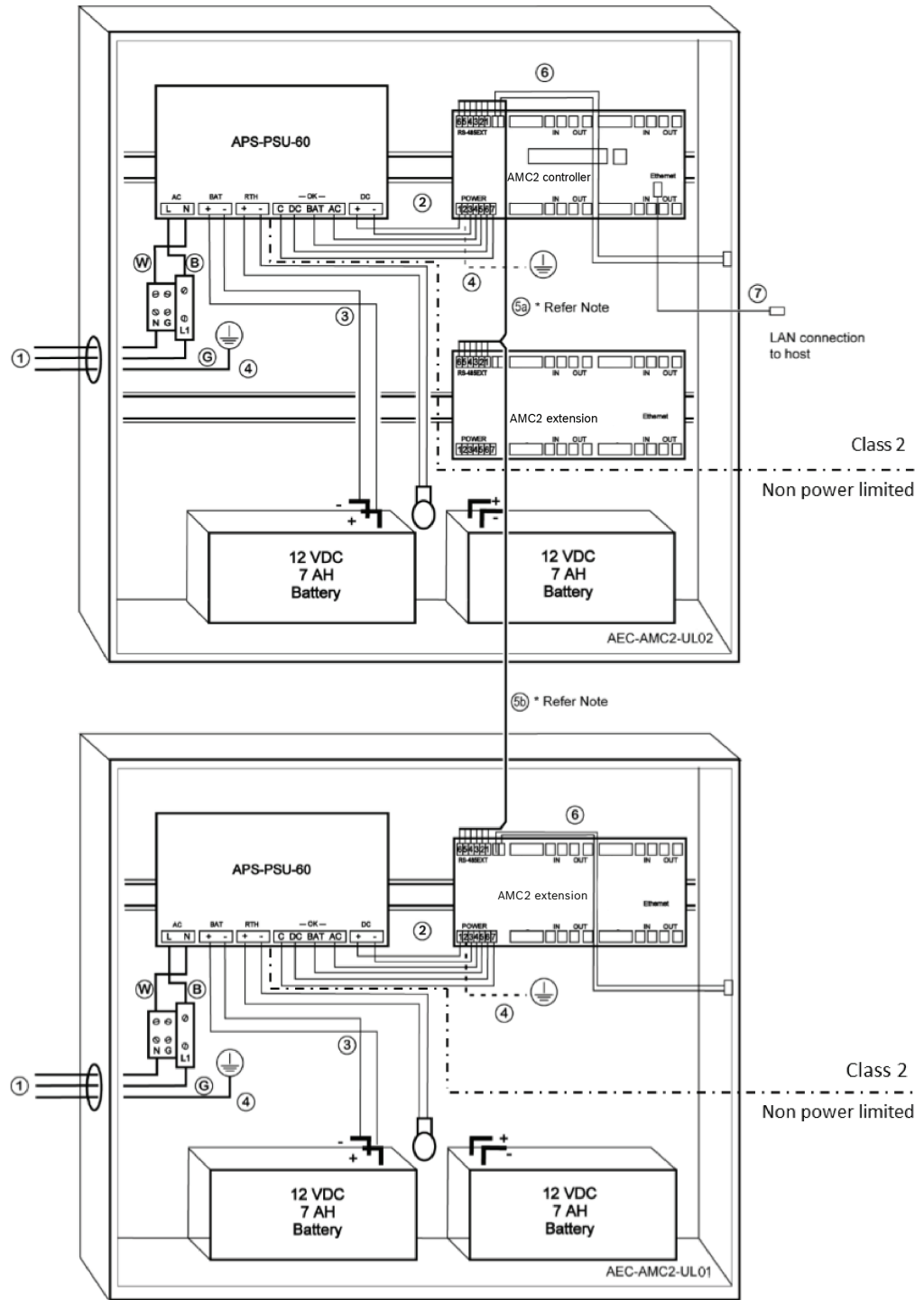



Figure 5.1: Example of mountings with extensions

Position	Description	Position	Description
B	Black / brown	3	Battery connection
		4	Earth cable
W	Blue	5a	R-485 extension connection
		5b	

Position	Description	Position	Description
G	Green or green / yellow	6	Tamper connection
1	AC power connection	7	Ethernet cable
2	DC power to AMC2		Grounding points



Caution!

Risk of electrical interference.

Make sure to keep the class 2 conductors and the non-power limited conductors strictly separate.

- Avoid any crossing of the conductors of the two categories.
- Guide the conductors of the two categories through different knock-outs of the housing.

5.4 Extended technical specification

5.4.1 RS-485 extension

- RS-485 extension output power rated maximum 2.5 A @ 9.0 VDC to 30 VDC (the voltage output is dependent on board voltage input)

5.4.2 Power consumption

Power input	10 VDC to 30 VDC, maximum of 3 A
Power consumption	5 VA
Total combined output	3 A @ 10 VDC - 12 VDC 2.5 A @ 24 VDC - 30 VDC

6 Troubleshooting

If problems occur read the table below.

Adjust only those controls specified in the installation manual. Improper adjustment of other controls may result in damage, and require extensive work by a qualified technician to restore the unit to normal operation.

If you are unsure of the problem or if the problem persists, contact *After sales support*, page 34.

The input and output signals of the extension modules are controlled by the controller to which they are connected. The setting of the signals can be checked on the display of the respective controller.

Problem	Cause	Solution
No response from inputs and outputs	<ul style="list-style-type: none"> – Extension module bus provides no power. OR – Power supply provides no power. 	<ul style="list-style-type: none"> – Make sure that the power supply used via the extension module bus is connected to the controller and that the controller is switched on. OR – Make sure that the power supply is correctly connected to the extension. – Check if the power supply of the PSU is present.
No response from input.	No feedback from the inputs in the system.	<ul style="list-style-type: none"> – Check the display of the controller to make sure the signal is set when the input is short-circuited. – Check the configuration of the controller. If necessary, reset the controller to Factory Default to delete all configuration data. – Reset the controller as described in Resetting the software.
No reaction at the output.	Door opener or signal is not activated.	<ul style="list-style-type: none"> – Check the display of the controller to make sure the signal is set. Check the configuration settings within AMS or ACE system.

Problem	Cause	Solution
		<ul style="list-style-type: none">- Make sure that the internal power supply jumpers are set correctly.

7 Service and repair

The extension is backed by a standard warranty of 3 years. Contact your dealer to buy a warranty extension.



Warning!

Risk of electric shock

Opening or removing the covers can expose you to dangerous voltages. An electric shock can cause injuries or death. Do not perform servicing tasks yourself. Refer all servicing to qualified service personnel.

Damage that requires service

Disconnect the controller and/or extension from the main AC or DC power source and refer servicing to qualified service personnel under the following conditions:

- If the power supply cord or plug is damaged.
- If liquid has been spilled or an object has fallen into the device.
- If the device has been exposed to water and/or humid weather (rain, snow, etc.).
- If the device has been dropped or the cabinet damaged.
- If the device shows a distinct change in performance.

Safety check

Upon completion of service or repair work on the controller, ask the service technician to perform safety checks to ensure that the controller operates properly.

After sales support

For more information, visit www.boschsecurity.com/xc/en/support/.

8

Disposal

Old electrical and electronic equipment

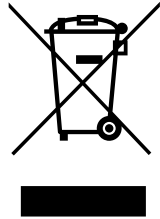

This product and/or battery must be disposed of separately from household waste. Dispose such equipment according to local laws and regulations, to allow their reuse and/or recycling. This will help in conserving resources, and in protecting human health and the environment.

Data security

According to the General Data Protection Regulation (GDPR), companies are obliged to properly delete or destroy data carriers containing personal data if they are no longer needed.

Since access controllers and readers can contain sensitive information, these should be treated and disposed of as data carriers after use.

The controller has a CF card as storage medium. When disposing of the controller, ensure that the CF card or the complete controller is destroyed or disposed of in accordance with the Local Data Protection Ordinance.

9 Technical specifications

Mechanical

Color	White
Dimensions (H x W x D) (mm)	90 mm x 232 mm x 63 mm
Dimensions (H x W x D) (in)	3.5 in x 8.9 in x 2.5 in
Material	Plastic (ABS)
Mounting type	DIN-rail
Weight (kg)	0.418 kg
Weight (lb)	0.92 lb

Environmental

Operating temperature (°C)	0 °C – 45 °C
Operating temperature (°F)	32 °F – 113 °F
Operating relative humidity, non-condensing (%)	0% – 95%
IP rating	IP30
RoHS	Compliant

Capacity

Number of analog inputs	16
Number of relay outputs	16

Connectivity

Extension interface	RS485
---------------------	-------

Electrical

Input voltage (VDC)	10 VDC – 30 VDC
Power consumption (VA)	5 VA

10

10.1

Appendices

Connecting diagrams

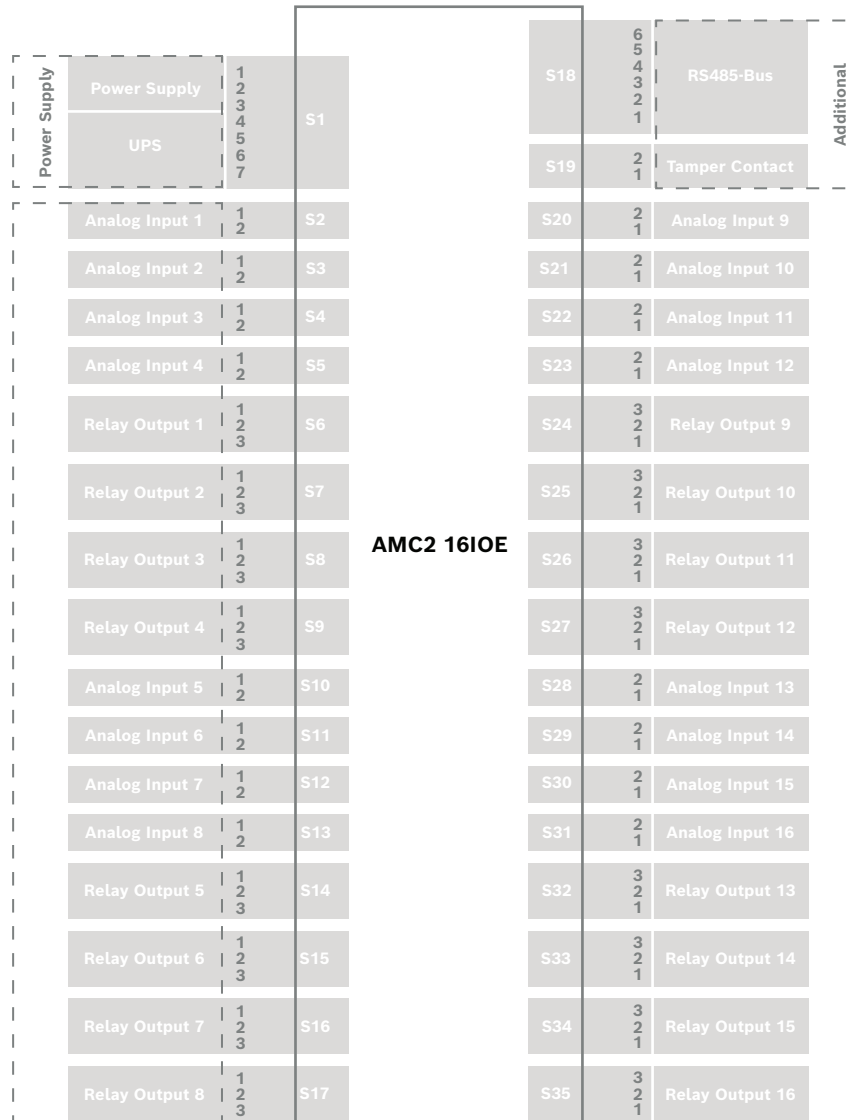

Figure 10.1: Connector blocks of the AMC2-16IOE

	1	Power supply, DC positive (10V - 30V)
	2	Shield
	3	Power supply (0V)
	4	UPS (power good signal) - AC
	5	UPS (power good signal) - Battery
	6	UPS (power good signal) - DC
	7	UPS (power good signal) - Common

Table 10.3: Power supply

	1	Analog Input
	2	Analog Input

Table 10.4: Analog input

	1	Relay Output, normally open
	2	Relay Output, common
	3	Relay Output, normally closed

Table 10.5: Relay output

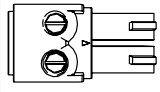

	1	Power supply (10V - 30V)
	2	Power supply GND
	3	Shield 
	4	Data RxTx+
	5	Data RxTx-
	6	PAG

Table 10.6: Extension module bus

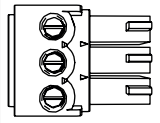
	1	Tamper Contact
	2	Tamper Contact

Table 10.7: External tamper contact

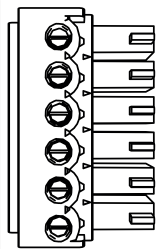

Support

Access our **support services** at www.boschsecurity.com/xc/en/support/.

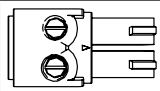
Bosch Security and Safety Systems offers support in these areas:

- [Apps & Tools](#)
- [Building Information Modeling](#)
- [Warranty](#)
- [Troubleshooting](#)
- [Repair & Exchange](#)
- [Product Security](#)



Bosch Building Technologies Academy

Visit the Bosch Building Technologies Academy website and have access to **training courses**, **video tutorials** and **documents**: www.boschsecurity.com/xc/en/support/training/

Bosch Security Systems B.V.

Torenallee 49

5617 BA Eindhoven

Netherlands

www.boschsecurity.com

© Bosch Security Systems B.V., 2024

Building solutions for a better life

202404031639